

# Workshop Manual

## Engine

|             |
|-------------|
| <b>C</b>    |
| <b>2(0)</b> |

**5.0GL-A/B/C/D/E**

**5.0GXi-A/B(F)/C(F)/D(F)/E(F)**

**5.0OSi-B(F)/C(F)/D(F)/E(F)**

**5.7GL-A/B/C/D/E**

**5.7Gi-A/B(F)/C(F)/D(F)/E(F)**

**5.7GXi-A/B/C(F)/D(F)/E(F)/F(F)**

**5.7OSi-A(F)/B(F)/C(F)/D(F)/E(F)**

**5.7OSXi-A(F)/B(F)/C(F)/D(F)/E(F)**

**5.7Gi-A/B/C/D/F**

**5.7GXi-A/B/C/D/F**



---

|  |            |
|--|------------|
| <b>General Information</b>                 | <b>1</b>   |
| <b>General Mechanical</b>                  | <b>27</b>  |
| <b>Engine — 5.0 &amp; 5.7 Liter</b>        | <b>51</b>  |
| <b>Steering System</b>                     | <b>163</b> |
| <b>Throttle &amp; Shift Control System</b> | <b>185</b> |
| <b>Cooling System</b>                      | <b>193</b> |
| <b>Engine Removal and Installation</b>     | <b>213</b> |
| <b>Safety</b>                              | <b>S</b>   |

## Model Identification

All stern drive system components must be matched for either single or dual engine installations. Failure to properly match engine, transom bracket and sterndrive will result in poor boat performance, and risk damage to engine and drive because of incorrect drive gear ratio.

Model identification is located on the engine, and **MUST** correspond with the transom shield and sterndrive numbers as listed in the Product Matrix sheet available separately.

## Engine Model Number

### All Engine Models

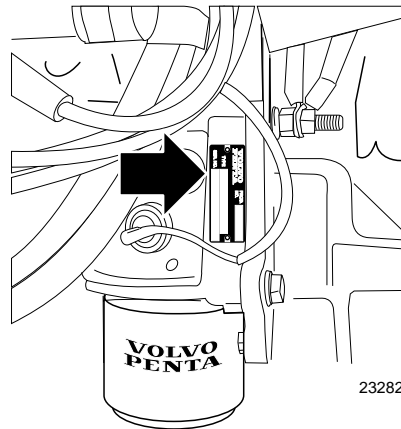

### GL Models

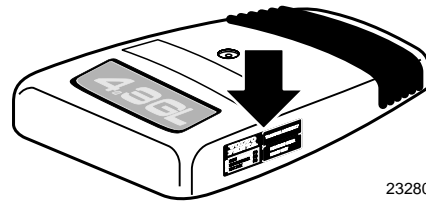
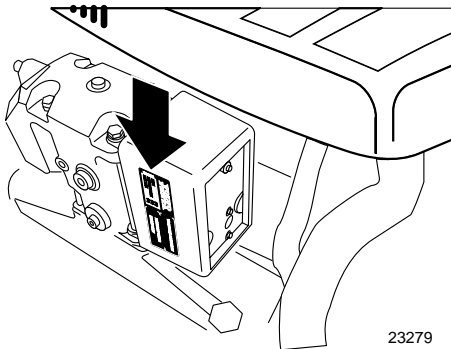

### Gi, GXi, OSi and OSXi Models

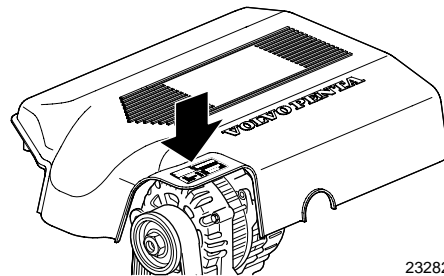
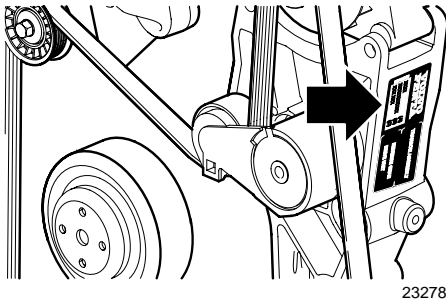

# Emission Control Labels

GLModels    Gi, GXi, OSi and OSXi Models

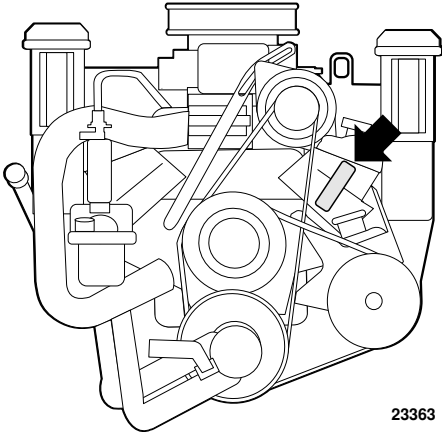

23363

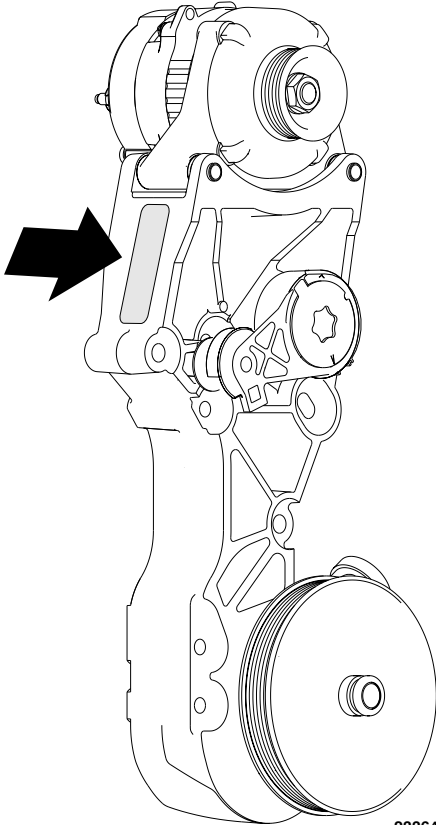

23364

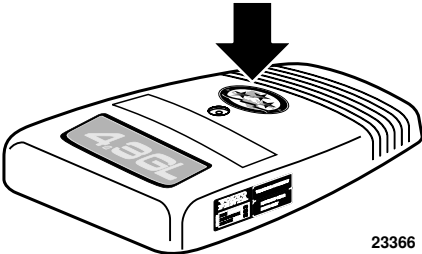

23366

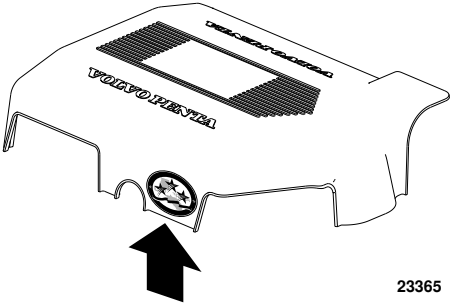

23365

## Transom Shield Model Number Location

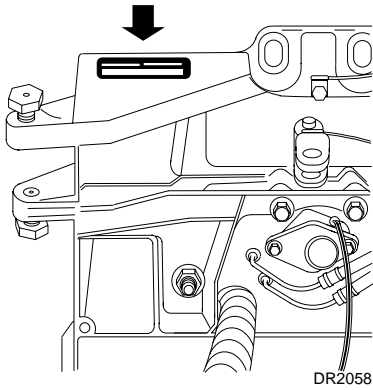

## Sterndrive Model Number Location

SX and DP-S

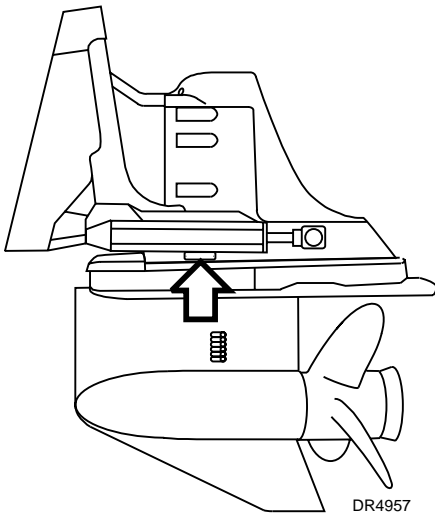

XDP-B

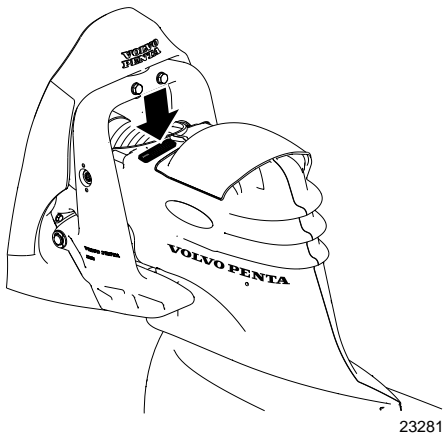

# Section 1: General Information

- Tuning the Engine ..... 3
  - Engine Compression Testing ..... 3
  - Test Conclusion ..... 3
  - Ignition System Components ..... 4
  - Fuel System Components ..... 4
  - Intake Manifold Vacuum Testing ..... 5
  - Gasoline Requirements ..... 7
  - Gasoline Containing Alcohol ..... 7
- Crankcase Oil ..... 8
- Steering System Lubrication ..... 9
- Power Trim/Tilt Fluid Level ..... 10
- Off-Season Storage ..... 10
- Preparation for Boating After Storage ..... 12
- Engine Break-in ..... 13
- Submerged Engine ..... 15
- 20-Hour Check ..... 15
- Belt Tension ..... 16
  - Alternator Belt Adjustment ..... 16
  - Power Steering Pump Belt Adjustment ..... 16
- Positive Closed-Type Ventilation System ..... 17
- Troubleshooting - System Isolation ..... 18
- Engine Troubleshooting Guides ..... 18
  - Engine Will Not Crank ..... 20
  - Engine Cranks, But Will Not Start ..... 20
  - Hard Starting - Cold Engine ..... 21
  - Hard Starting - Hot Engine ..... 21
  - Engine Runs Rough ..... 21
  - Engine Noises and Vibrations ..... 22
  - Engine Overheats - Check: ..... 23
  - Engine Dies Out ..... 23
  - Engine Won't Reach Operating RPM - Check: ..... 24
  - Defective Engine Lubricating System ..... 24
  - Low Battery Voltage After Short Storage ..... 24

This service manual is divided into sections concerning various systems and assemblies. Refer to the **Contents** to locate the section covering the system or assembly requiring service. Each section title page has an additional listing that will describe the sections contents in

more detail. Be sure to read the **Safety Section** at the end of this manual, and pay special attention to all safety warnings as they appear throughout the text. Since models are subject to change at any time, some photos may not depict actual product.

### Good Service Practice

Service required for stern drives is generally one of three kinds:

- **Normal care and maintenance** - which includes putting a new stern drive into operation, storing engines, lubrication, and care under special operating conditions such as salt water and cold weather.
- **Operating malfunctions** - due to improper engine or drive mounting, propeller condition or size, boat condition, or the malfunction of some part of the engine. This includes engine servicing procedures to keep the engine in prime operating condition.
- **Complete disassembly and overhaul** - such as major service or rebuilding a unit.

It is important to determine before disassembly just what the trouble is and how to correct it quickly, with minimum expense to the owner.

When repairing an assembly, the most reliable way to ensure a good job is to do a complete overhaul on that assembly, rather than just to replace the bad part. Wear not readily apparent on other parts could cause malfunction soon after the repair job. Repair kits and seal kits contain all the parts needed to ensure a complete repair, to eliminate guesswork, and to save time.

Repair time can also be minimized by the use of special tools. Volvo Penta special tools are designed to perform service procedures unique to the product that cannot be completed using tools from other sources. They also speed repair work to help achieve service flat rate times. In some cases, the use of substitute tools can damage the part.

### Preparation for Service

Proper preparation is extremely helpful for efficient service work. A clean work area at the start of each job will minimize tools and parts becoming misplaced. Clean an engine that is excessively dirty before work starts. Cleaning will occasionally uncover trouble sources. Obtain tools, instruments and parts needed for the job before work is started. Interrupting a job to locate special tools or repair kits is a needless delay.



**Caution! Use proper lifting and handling equipment.**

**Working on stern drives without proper equipment can cause damage and personal injury.**

Always use clean fresh fuel when testing engines. Troubles can often be traced to the use of old or dirty fuel.

### Service Policy

It is a Volvo Penta policy to provide dealers with service knowledge so they can give professional service demanded by today's consumer. The Volvo Penta Training Centers, frequent mailing of Service Bulletins, Letters and Promotions, Special Tools and this Service Manual represent the latest effort to assist dealers in giving consumers the best and most prompt service possible. If a service question does not appear to be answered in this manual, you are invited to write to the Volvo Penta Service Department for additional help. Always be sure to



give complete information, including engine model number and serial number.

### Replacement Parts



**When replacement parts are required, always use genuine Volvo Penta parts, or parts with equivalent characteristics, including type, strength, and material. Failure to do so may result in product malfunction and possible injury to the operator and/or passengers.**

### Parts Catalogs

Parts Catalogs contain exploded views showing the correct assembly of all parts, as well as a complete listing of the parts for replacement. These catalogs are helpful as a reference during disassembly and reassembly, and are available from Volvo Penta Parts.

### Special Service Tools

Volvo Penta has specially designed tools to simplify some of the disassembly and assembly operations. These tools are illustrated in this Service Manual, in many cases in actual use. All special tools can be order from Volvo Penta Parts. Individual purchasers of Service Manuals must order Special Tools through an authorized dealer.

### Product References, Illustrations & Specifications

Volvo Penta reserves the right to make changes at anytime, without notice, in specifications and models and also to discontinue models. The right is also reserved to change any specifications or parts at any time without incurring any obligation to equip same on models manufactured prior to date of such change. All information, illustrations and specifications contained in this manual are based on the latest product information available at the time of printing. The right is reserved to make changes at anytime without notice.

All photographs and illustrations used in this manual may not depict actual models or equipment, but are intended as representative views for reference only. The continuing accuracy of this manual cannot be guaranteed.

The purpose of an engine tune-up is to restore power and performance that has been lost through wear, corrosion or deterioration of one or more parts or components. In the normal operation of an engine, these changes can take place gradually at a number of points, so that it is seldom advisable to attempt an improvement in performance by correction of one or two items only. Time will be saved and more lasting results will be obtained by following a definite and thorough procedure of analysis and correction of all items affecting power and performance.

Economical, trouble-free operation can better be ensured if a complete tune-up is performed once every year, preferably in the spring. Components that affect power and performance can be divided into three groups:

- Components affecting compression
- Components affecting ignition
- Components affecting fuel system

## Tuning the Engine

Tune-up procedures should cover these groups in the order given. While the items affecting compression and ignition may be handled

according to personal preference, correction of items in the fuel system group should not be attempted until all items affecting compression and ignition have been satisfactorily corrected. Most of the procedures for performing a complete engine tune-up will be covered in greater detail in this manual. This section will deal mainly with the order of procedures involved in tuning the engine.

### Engine Compression Testing

During all work done around the engine, while the engine is running or being cranked, use extreme care to avoid getting fingers or clothing caught in any belts, pulleys, or other moving parts.

2. Visually inspect stern drive unit for leaks, missing parts or other obvious defects. **Replace deteriorated parts.**
3. Compression check: Proper compression is essential for good engine performance. An engine with low or uneven compression cannot be properly tuned.
  - Operate engine to normal operating temperature.



**Engine must not be started and run without water for cooling.**

- Remove any foreign matter from around spark plugs by blowing out with compressed air.
- Remove and inspect all spark plugs. Install thread-type compression gauge in spark plug hole.
- **To Prevent Sparking:**
  - Remove (grey) 2-wire connector, with purple and grey wires, at ignition coil.
  - With choke and/or throttle plates wide open, crank engine through at least four compression strokes.

### Test Conclusion

The indicated compression pressures are considered normal if the lowest reading cylinder is within 75% of the highest.

Example:

If the highest pressure reading was 140 PSI, 75% of 140 is 105. Therefore, any cylinder reading less than 105 PSI indicates an improperly seated valve, worn valve guides, piston, cylinder, or worn or broken piston rings. Any cylinder reading 105 PSI or greater is within specifications, and compression is considered normal.

If one or more cylinders read low, squirt approximately one tablespoon of engine oil on top of the pistons in the low reading cylinders. Repeat compression pressure check on the cylinders.

1. If compression improves considerably, the piston rings are at fault.
2. If compression does not improve, valves are sticking or seating poorly, or valve guides are worn.
3. If two adjacent cylinders indicate low compression pressures and squirting oil on the pistons does not increase the compression, the cause may be a cylinder head gasket leak between the cylinders. This problem could allow engine oil and/or coolant to enter the cylinders. It is recommended the following quick reference chart be used when checking cylinder compression pressures. The chart has been calculated so that the lowest reading number is 75% of the highest reading.

Table 1: Compression Pressure Limit

| Max. PSI | Min. PSI | Max. PSI | Min. PSI | Max. PSI | Min. PSI | Max. PSI | Min. PSI |
|----------|----------|----------|----------|----------|----------|----------|----------|
| 134      | 101      | 154      | 115      | 174      | 131      | 194      | 145      |
| 136      | 102      | 156      | 117      | 176      | 132      | 196      | 147      |
| 138      | 104      | 158      | 118      | 178      | 133      | 196      | 148      |
| 140      | 105      | 160      | 120      | 180      | 135      | 200      | 150      |
| 142      | 107      | 162      | 121      | 182      | 136      | 202      | 151      |
| 144      | 108      | 164      | 123      | 184      | 138      | 204      | 153      |
| 146      | 110      | 166      | 124      | 186      | 140      | 206      | 154      |
| 148      | 111      | 168      | 126      | 188      | 141      | 208      | 156      |
| 150      | 113      | 170      | 127      | 190      | 142      | 210      | 157      |
| 152      | 114      | 172      | 129      | 192      | 144      | 212      | 158      |

After checking cylinder compression, repairs should be made as necessary. Subsequent adjustments to an engine that does not have proper compression will not measurably improve performance or correct operational problems. After verifying compression, check ignition and fuel system components.

#### Ignition System Components

- Spark Plugs
- Spark Plug Leads
- Distributor Cap
- Rotor
- Ignition Coil
- High Tension Lead
- Ignition Switch
- Circuit Wiring and Connectors

#### Fuel System Components

- Fuel Tank Pickup and Screen
- Fuel Tank Vent
- Anti-Siphon Valve (if equipped)
- Fuel Octane and Quality
- Boat Fuel Lines and Valves
- External Engine Fuel Filter
- Fuel Pump(s) and Line
- Carburetor Fuel Filter or Screen
- Carburetor Adjustments
- Engine PCV Valve
- Flame Arrestor

All of the above listed components are not necessarily part of an engine tune-up, but must be considered when attempting to correct

engine/boat performance problems. Repair or replace components only as required.



**Do not substitute automotive parts. Volvo Penta marine components meet U.S. Coast Guard regulations for external ignition proof operation and marine use. Volvo Penta marine components are specially designed not to cause ignition of fuel vapors in the bilge or engine compartment. The use of automotive parts can result in fire and explosion.**

## Intake Manifold Vacuum Testing

### Test Procedures

1. Install a vacuum gauge to a good intake manifold source (usually at the PCV valve port), following the gauge manufacturer's instructions. Start and warm up the engine.
2. Observe the vacuum gauge while operating the engine over a range of engine speeds.

### Test Results

1. A steady vacuum reading between 14 and 19in. Hg. (47-64 kPa) at idle indicates an engine in good mechanical condition.
2. A vacuum reading below 14 in. Hg. (47 kPa) at idle, indicates an engine that is not developing enough vacuum. Further testing for base mechanical problems is needed.
3. Possible causes of low intake manifold vacuum are late ignition timing, low compression, poor engine sealing, leaks at vacuum lines and connections or bad MAP sensor.
4. If the gauge fluctuates at idle, possible causes are sticking or leaking valves, or an ignition miss.
5. If the gauge fluctuates at idle but smooths out as engine RPM increases, check for bad valves or camshaft.
6. If the gauge fluctuates more with increases engine RPM, check for weak or broken valve springs, bad valves, ignition miss, or a leaking head gasket.
7. If the vacuum gauge fluctuates regularly with each engine cycle, check for a bad valve.
8. If the vacuum reading drops steadily as engine RPM increases, check the exhaust system between the engine and sterndrive for restrictions.
9. See table and chart below and on the following page for more information.

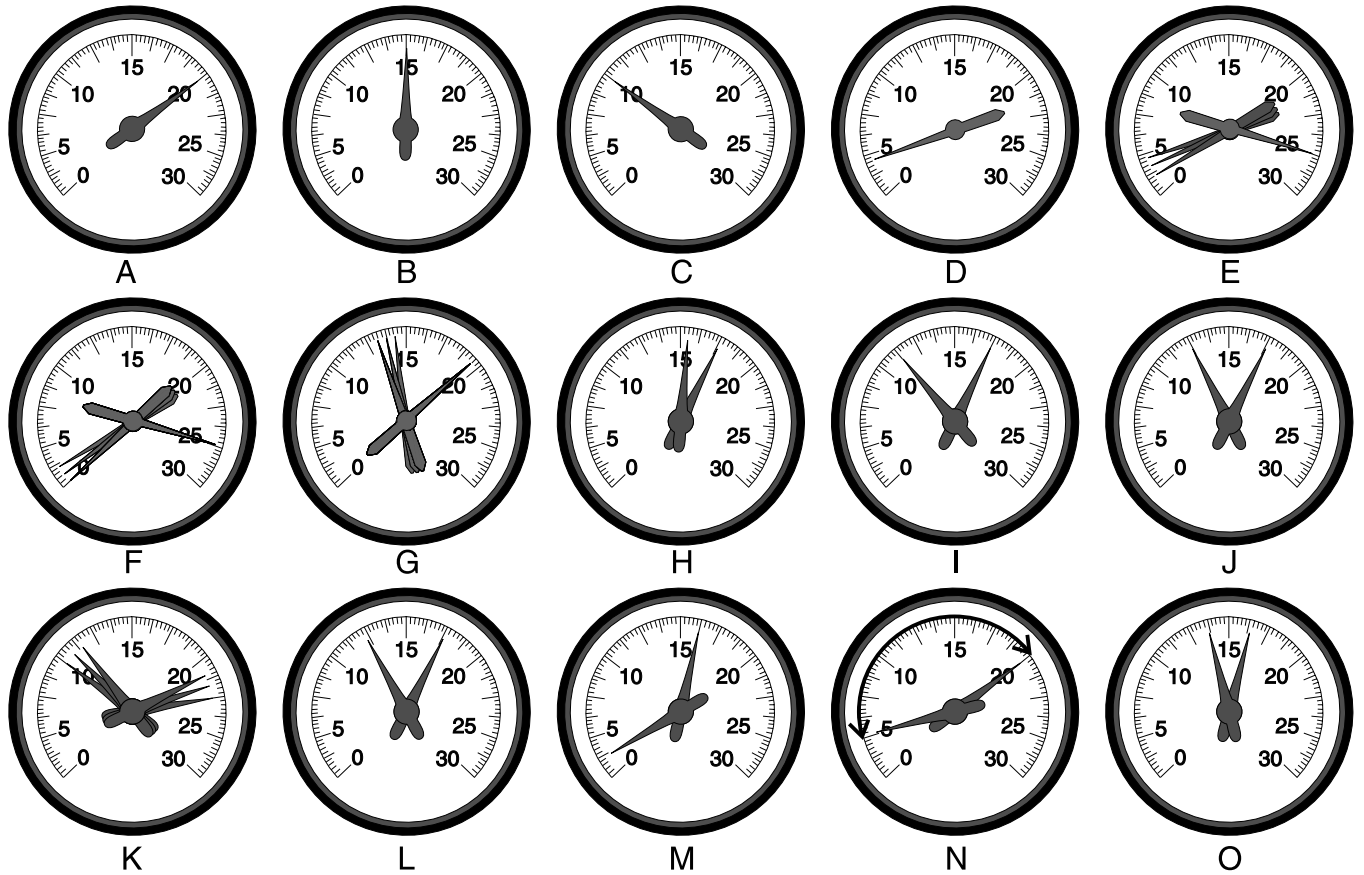

Table 2: Vacuum Gauge Readings

| Pos | Condition              | Reading  |
|-----|------------------------|--|
| A   | Normal at Idle         | 14-19 in. Hg. (47-64 kPa)  |
| B   | Late Ignition Timing   | 11-17 in. Hg. (37-57 kPa)  |
| C   | Late Valve Timing      | 8-15 in. Hg. (27-50 kPa).  |
| D   | Intake Leak            | Low but steady reading   |
| E   | Normal Acceleration    | Drops to 2 then rises to 25 when throttle is rapidly increased and decreased.                  |
| F   | Worn Rings             | Drops to 0, then rises to 22 when throttle is rapidly increased and decreased                  |
| G   | Sticking Valve(s)      | Normally steady, intermittently flicks downward approx. 4 in. Hg. (13 kPa) from highest level. |
| H   | Leaking Valve          | Drops 2 in. Hg. (6 kPa) from highest reading.  |
| I   | Burned or Warped Valve | Evenly spaced down-scale flicker approximately 5 in. Hg (17 kPa).                              |
| J   | Worn Valve             | Oscillates Approximately 4 in. Hg. (13 kPa).   |
| K   | Weak Valve Springs     | Violent oscillations as RPM increases.   |
| L   | Improper Idle Mixture  | Floats slowly between 13-17 in. Hg. (44-57 kPa)  |

**Table 2: Vacuum Gauge Readings**

| Pos | Condition                    | Reading  |
|-----|------------------------------|--|
| M   | Restricted Exhaust           | Normal when first started. Drops to approx. 0 as RPM increases |
| N   | Head Gasket Leak             | Floats between 5-20 in. Hg. (17-68 kPa)                        |
| O   | Defective Ignition Component | Slight float between 14-16 in. Hg. (47-54 kPa)                 |

**Gasoline Requirements**



**DANGER!**

**Gasoline is extremely flammable and highly explosive under certain conditions. Always stop engine and do not smoke or allow open flames or sparks near the boat when refuelling gas tanks. When filling the gas tank, ground the tank to the source of gasoline by holding the hose nozzle firmly against the side of the deck filler plate, or ground it in some other manner. This action prevents static electricity buildup which could cause sparks and ignite fuel vapors.**

**USE ONLY UNLEADED FUEL.** Use lead-free gasoline with the following minimum or higher octane specification:

Inside the U.S.: (R+M)/2 (AKI) = 87

Outside the U.S.: (RON) = 90

If fuels with 89 AKI pump posted (93 RON) octane number or higher are used an increase in power can be expected with EFI models.

Premium fuels contain injector cleaners and other additives that protect the fuel system and provide optimum performance.



**Caution!**

**Engine damage resulting from the use of gasoline with octane 86 AKI (89 RON) and lower is considered misuse of the engine and will void the engine warranty. Volvo Penta suggests the use of 89 AKI or higher fuels. These fuels have additives that are beneficial to maximum engine performance and long life of service components.**

To prevent gum formation and corrosion in the fuel system, use a Marine Fuel Stabilizer in the gasoline.

**Gasoline Containing Alcohol**

Many brands of gasoline being sold today contain alcohol. Two commonly used alcohol additives are Ethanol (ethyl alcohol) and Methanol (methyl alcohol).

See the Owner's Manual for you boat to determine if the boat's fuel system is compatible with alcohol blended fuels. if it is compatible, your engine may be operated using gasoline blended with no more than 10% Ethanol (ethyl alcohol) meeting the minimum octane specifications.



**Caution!**

**Do not use any gasoline which contains Methanol (methyl alcohol).**

See the boat's Operators Manual to determine if the boat's fuel system is compatible with alcohol blended fuels. If it is, your engine may use gasoline blended with no more than 10% Ethanol (ethyl alcohol) meeting the minimum octane specification. **Do not use any gasoline which contains METHANOL (methyl alcohol).**

Continued use of **METHANOL** (methyl alcohol) fuel will cause serious damage to the fuel system.

If you use gasoline containing alcohol, be aware of the following:

- The engine will operate leaner. This may cause engine problems such as vapor lock, low speed stalling, or hard starting.
- Alcohol blended fuels attract and hold moisture. Moisture can cause fuel tank corrosion. Inspect fuel tanks at least annually. Replace corroded or leaking fuel tanks.
- Frequently inspect non-metallic parts of fuel system and replace if excessively stiff, deteriorated or leaking.

Fuel leakage can contribute to a fire and/or explosion.

## Crankcase Oil

Initial factory fill is a high quality motor oil for API Service SH. During the break-in period (20 hours), frequently check the oil level. Somewhat higher oil consumption is normal until piston rings are seated. The oil level should be maintained in the safe range between the Add and Full marks on the dipstick. This range represents approximately 1 litre (1 quart). If it is necessary to add or change the motor oil, use a quality oil with API service category SH.

At the end of the break-in period (20 hours), change the crankcase oil and replace the oil filter. Refer to **Lubrication and Inspection Chart** for recommended oil change intervals.

**NOTE! The use of multi-viscosity oils, such as 10W-30 or 10W-40, is not recommended.**

### Draining and Filling the Engine Crankcase

If using Volvo Penta Premium Synthetic Engine Oil, drain and refill crankcase every 200 hours of operation or once a year, whichever occurs first.

If using oil other than Volvo Penta Premium Synthetic Engine Oil, drain and refill crankcase every 100 hours of operation or once a year, whichever occurs first.



#### **DANGER!**

**To prevent fire and explosion, always make sure engine compartment is free of gasoline fumes before using any spark-producing tools such as the electric drill motor used with oil withdrawal pump kit.**

Check the motor oil level frequently with the dipstick. When oil is to be changed, remove dipstick and withdraw oil from crankcase through

withdrawal/dipstick tube. The oil withdrawal tube is provided so oil does not have to be drained into the bilge. Withdraw oil with a suction pump.

Fill the crankcase to the specified capacity with a quality motor oil labelled for service category SH. When changing motor oil, select from the following chart the SAE viscosity that matches the temperature range in which the boat will be operated. If it is necessary to add motor oil, use motor oil of the same viscosity.

**Table 3: Temperature Viscosity Recommendations**

| If the lowest Anticipated Temperature is: | The Following SAE Viscosity Oils are Recommended |
|---|--|
| 32° F (0° C) and above                    | SAE 30   |
| 0° F (-18° C) to 32° F (0° C)             | SAE 20W-20                                       |
| Below 0° F (-18° C)                       | SAE 10   |

**NOTE! Disregard any reference to multi-viscosity oil printed on engine. Such reference is intended for automotive use only and not marine application.**



**Caution!**

**Do not fill above full mark. Overfilling results in high operating temperatures, foaming (air in oil), loss of power, and overall reduced engine life.**

**Table 4: Crankcase Capacities**

| Model | Less Filter           | With Filter          |
|-------|-----------------------|----------------------|
| 5.0   | 4.5 qts. (4.2 liters) | 5.5 qts (5.2 Liters) |
| 5.7   | 4.5 qts. (4.2 liters) | 5.5 qts (5.2 Liters) |

**Oil Filter** Replace the oil filter whenever the motor oil is changed. This filter is a self-contained, screw-on type. To remove, unscrew filter canister counterclockwise and discard. When attaching a new filter, be sure the gasket is lightly lubricated with motor oil. Hand tighten only, run engine and check for leaks. Do not run engine without supplying cooling water. See *Parts Catalog* for model and filter requirements.

## Steering System Lubrication

Maintain the level with Volvo Penta Power Trim/Tilt & Steering Fluid. Approved power steering fluids such as GM power steering fluid or Dexron II automatic transmission fluid can also be used. Do not overfill the pump reservoir.

At the beginning of each boating season, grease the steering ram with Volvo Penta grease.

## Power Trim/Tilt Fluid Level

At the beginning of each boating season, check the fluid level in the reservoir as follows:



## Power Trim/Tilt Fluid Level

At the beginning of each boating season, check the fluid level in the reservoir as follows:

- Level should be between the “MIN” and “MAX” marks on the reservoir.
- If necessary, add Volvo Penta Power Trim/Tilt & Steering Fluid. Replace the cap and tighten securely.

## Off-Season Storage

There are nine steps that must be completed for Off-Season Storage Preparation

When gasoline engines are removed from service for long periods (2 months or more), it is important that they are correctly stored or protected (internally). Today’s gasoline blends are not as stable as in the past and consideration must be given if the fuel will not be used within a short time or if the engine is being placed in storage. Failure to properly stabilize the fuel can damage fuel system components and is not considered as warrantable.

**Boat manufacturers should follow the gasoline storage mixture section for testing prior to shipment.**

**Note! Volvo Penta has discontinued fuel stabilizer P/N 3855832, a suitable replacement can be purchased locally at most automotive supply stores.**

|                    |   |
|--------------------|---|
| <b>Limited Use</b> | If the vessels fuel within the tank(s) will not be consumed within a 30-day period from the time of filling, a gasoline fuel stabilizer must be added as per the manufacturers instructions. This will help prevent the fuel from breaking down and causing reduced engine performance or damage from uncontrolled combustion.  |
| <b>Storage</b>     | If the boat is being placed into storage, a gasoline fuel stabilizer must be added to the tank(s) as per the manufacturers instructions. The amount of stabilizer required is determined by the quantity of fuel and the length of time it will be placed in storage. The maximum period that fuel can be stabilized is six months due to limitations of the stabilizers and fuels. |



### **DANGER!**

**Any fuel leakage should be corrected immediately to prevent possible fire and/or explosion.**



### **Caution!**

**Do not run engine out of fuel or run the electric fuel pumps dry more than 20 seconds. Running the electric fuel pumps dry will cause fuel pump damage.**

### **Step 1. Prepare a storage mixture**

In addition to stabilization of the fuel, it is highly desirable to have the valves and cylinders coated with a light film of oil previously accomplished through fogging. Today’s fuel injection manifolds are designed with a complex air channel design that will not allow the traditional fogging oils to be injected past the throttle plate while running. The oil will

get stuck in the plenum and never reach the cylinders. Together with the stabilizer, two-cycle motor oil can be added to a fuel mixture for stabilization purposes.

- Using an outboard motor six-gallon fuel tank, add two-cycle motor oil at a ratio of 50:1 (one pint to 6 gallons) and stabilizer at one ounce per gallon (unless stated otherwise on the manufacturer's label). Mix well.
- Disconnect boat fuel line at engine fuel pump. Attach the storage mixture fuel tank.
- Connect a suitable engine flush device if the boat is not in the water.
- Run the engine on the storage mixture for approximately 5 minutes at 1500 RPM. This will ensure that all fuel system and internal engine components are thoroughly protected. Do not operate the engine above 1500 RPM as the water pump demand may exceed the supply, damaging the pump.
- Reduce the engine speed to idle and stop the engine.
- Reconnect the fuel fitting and check for fuel leaks.

### **Electric Fuel Pumps and Fuel Cells**

Regardless of the ratio of fuel stabilizer to fuel we use, the maximum recommended storage time for gasoline, according to STA-BIL, is six months. During final assembly testing at our Lexington factory, each engine is run on a fuel mix that is stabilized. Each engine is shut off without running the fuel pumps dry and the fuel system is sealed to prevent damage. With the delay in time between the product getting installed in a boat, shipped to you, sold and finally delivered; the six-month time frame can easily be exceeded.

Since delivering a quality, dependable product is one of our highest goals; we work closely with our suppliers to identify the root cause of failure on any parts returned for warranty credit. While there are certainly legitimate failures of fuel pumps, the major portion of them are returned to us due to varnished fuel from long term storage. We would like to offer some advice on dealing with these issues.

#### **Stuck Pumps**

If a fuel pump appears stuck and will not operate, you may try briefly reversing the polarity to the pump to turn it in the opposite direction. You should disconnect the electrical plug of one pump at a time on the fuel cell to determine which pump might have a problem.

#### **Noisy Fuel Pumps**

Electric pumps will often cavitate and become noisy if they are starving for fuel. On carbureted engines or low-pressure fuel cell pumps, check the fuel supply, quality of the fuel hose, anti-siphon valve, and filter before replacing the fuel pump.

A noisy high-pressure pump on a fuel cell may indicate a low fuel level in the reservoir. Check the fuel supply and low pressure pump operation to be sure the reservoir is receiving the correct volume of fuel. The same information would apply to engines with the earlier vapor separator tank design.

This information may help prevent the needless replacement of pumps in many cases and reduce the repair time for the boat owner.

**Step 2. Change Motor Oil and Oil Filter:**

- Engine should first be operated under load until oil is thoroughly warmed up. If oil is allowed to warm up before draining, a more complete draining will be accomplished. In addition, accumulated impurities will be held in suspension by the oil and be removed during draining operation.
- Remove motor oil by siphoning it out of oil withdrawal tube. Follow the procedure under **Draining and Filling the Engine Crankcase**.
- Install a new oil filter and fill crankcase with recommended oil.

 **Caution!**

**Sterndrive must be submerged in water or water must be supplied to the raw water pump while operating engine. If using a flushing adaptor, remove propeller before starting engine to prevent accidental contact with rotating propeller.**

- With sterndrive in full down position, run engine at a fast idle for a few minutes to distribute clean oil through engine.
- Shut off engine and check oil level. Check oil filter gasket for leaks. Add oil if necessary to bring oil level up to, but not over, the full mark.

**Step 3. Change Sterndrive Lubricant:**

Drain and refill with fresh Volvo Penta GL-5 Synthetic Gear Lubricant or Mobilube 1 SHC Fully Synthetic SAE 75W-90 (meeting or exceeding MIL-L-2105C or D, API GL-4 or 5) gear lubricant. Refer to Sterndrive Service Manual.

**Step 4. Fog Engine:****Carbureted Models Only:**

- Warm up engine to ensure fuel conditioner is throughout fuel system. Use 1/2 pint (0.24 liter) of Fogging Oil 12 oz. (355 ml) spray can to fog engine.
- Remove flame arrester from carburettor. Following instructions on container, bring engine up to a fast idle and slowly pour or spray 2/3 of fogging oil into carburettor. Keep engine running while pouring fogging oil into carburettor throat.

**Step 5. Drain Cooling System**

See "Draining Engine Block or Exhaust Manifold" on page 212.

When draining the cooling system, raise or lower the bow of the boat to position the engine in a level horizontal plane. This will provide complete drainage of the engine block and manifolds. If the bow is higher or lower than the stern, some water may be trapped in the engine block or manifolds.

Improper or incomplete draining may result in freeze damage to the engine, manifolds, sterndrive, or other components. Freeze damage is not covered under Volvo Penta's Limited Warranty.

**Preparation for Boating After Storage**

1. Install all drain plugs. Install cooling hoses and clamps. Check condition of hoses, manifold end caps and clamps. Connect hoses to engine and tighten clamps securely. Install boat drain plug, if removed.

2. Remove the distributor cap and rotor. Wipe the inside of the distributor cap dry with a clean cloth and spray with a dielectric corrosion inhibitor. Replace the rotor and cap.
3. Clean the battery terminals. With the ignition switch in the "OFF" position, install the battery and attach the battery cables. Spray terminals with a dielectric corrosion inhibitor.
4. **Open the fuel shut-off valve (if so equipped) and check all fuel line connections for leaks.**
5. Check the flame arrestor and clean if necessary. **Reinstall, make sure all parts are in place and tighten nut securely.**
6. Make a thorough check of the boat and engine for loose or missing nuts and screws. Pump the bilge dry and air out the engine compartment.



**Danger!**

**To prevent a possible explosion, operate the blower as recommended by the boat manufacturer before starting engine. If the boat is not equipped with a bilge blower, open engine cover or hatch prior to starting and leave open until after engine is running.**

**If operating boat in water, tie boat securely to dock to prevent forward or backward movement.**

**When using a flushing adaptor, remove the propeller before starting engine to prevent accidental contact with rotating propeller.**

7. Test run engine: Launch boat or use a flushing adaptor installed on Sterndrive.



**Caution!**

**Do not start engine out of water unless water is supplied to the raw water pump. Always turn water on before starting engine. Control water pressure as full water pressure may cause damage to supply pump and engine.**

8. With engine compartment open, start the engine. Monitor the voltmeter, oil pressure and water temperature gauges frequently to be sure all systems are operating properly. **Check for fuel, oil, and water leaks.**

## Engine Break-in

All engines have been run for a short period of time as a final test at the factory. You must follow the Engine Break-In procedure during the first 20 hours of operation to ensure maximum performance and longest engine life.

**NOTE!**

**To ensure proper lubrication during the break-in period, do not remove factory break-in oil until after the 20-hour break-in is completed.**

**First Two Hours** For the first five to ten minutes of operation, operate engine at a fast idle (above 1500 RPM). After engine has reached operating temperature, momentarily reduce engine speed, then increase engine speed, to assist break-in of rings and bearings.

During the remaining first two hours of operation, accelerate to bring boat onto plane quickly and bring throttle back to maintain a planing attitude. During this period, vary the engine speed frequently by accelerating to approximately three-fourths throttle for two to three minutes, then back to minimum planing speed. Maintain planing attitude to avoid excessive engine load.

**DO NOT RUN ENGINE AT A CONSTANT RPM FOR PROLONGED PERIODS OF TIME DURING THE BREAK-IN PERIOD.**

**Next Eight Hours** During next eight hours, continue to operate at approximately three-fourths throttle or less (minimum planing speed). Occasionally reduce throttle to idle speed for a cooling period. During this eight hours of operation it is permissible to operate at full throttle for periods of less than two minutes.

**DO NOT RUN ENGINE AT A CONSTANT RPM FOR PROLONGED PERIODS OF TIME DURING THE BREAK-IN PERIOD.**

**Final Ten Hours** During the final ten hours of break-in, after warming engine to operating temperature, it is permissible to operate at full throttle for five to ten minutes at a time. Momentarily reduce then increase engine speed to assist break-in of rings and bearings. Occasionally reduce engine speed to idle to provide cooling periods.

**DO NOT RUN ENGINE AT A CONSTANT RPM FOR PROLONGED PERIODS OF TIME DURING THE BREAK-IN PERIOD.**

During break-in period, be particularly observant during initial running of engine, as follows:

1. Check crankcase oil level frequently. Maintain oil level in safe range, between "add" and "full" marks on dipstick.

**NOTE! If you have a problem getting a good oil level reading on dipstick, rotate dipstick 180° in tube.**

2. Watch oil pressure gauge. If indicator fluctuates whenever boat attitude (i.e. turning, climbing on plane, etc.) is changed, it may be the oil pickup screen is not covered with oil. Check crankcase dipstick, and add oil to crankcase if required. **DO NOT OVERFILL.** If oil level is correct and condition still exists, check for possible gauge or oil pump malfunction.

**NOTE! Oil pressure will rise as RPM increases, and fall as RPM decreases. In addition, cold oil will generally show higher oil pressure for any specific RPM than hot oil. Both of these conditions reflect normal engine operation.**

3. Watch engine temperature indicator to be sure there is proper water circulation.



### Caution

**Failure to follow the break-in procedure will void the engine warranty.**

At end of break-in period (20 hours), remove motor oil and replace oil filter. Fill crankcase with recommended 4-cycle motor oil.

### Operation After Break-in

After break-in, the engine can be operated at any RPM from idle to full throttle. However, cruising at 3600 RPM or less saves fuel, reduces noise, and prolongs engine life.

When starting a cold engine, always allow engine to warm up gradually. Never run engine at full throttle until engine is thoroughly warmed up. Be sure to check oil level frequently during the first 50 hours of operation, since oil consumption will be high until piston rings are properly seated.

## Submerged Engine

Remove engine from water as quickly as possible.

It is imperative that your dealer remove all water from the engine and immediately lubricate all internal parts. All electrical devices must also be dried and inspected for water damage. Delay in completing these actions may allow extensive engine damage.

Frequently check engine compartment for gasoline fumes and excessive water accumulation; water depth in bilge should be kept well below flywheel housing.

## 20-Hour Check

1. Change engine oil and oil filter.
2. Check power trim/tilt reservoir for proper fluid level.
3. Change fuel filter/water separator.
4. Check flame arrestor for proper mounting.
5. Start engine and check complete fuel system for leaks.
6. Lubricate steering cable ram with Volvo Penta grease. Check power steering pump reservoir for correct fluid level on models equipped with power steering.



### Caution!

**Failure to properly lubricate the steering system could lead to loss of steering control.**

7. Check shift system for proper adjustment and operation.
8. Inspect exhaust system. Tighten all hose clamps, and check for leaks.
9. Check tension on all drive belts.
10. Check all engine mount screws for tightness.
11. GL Models Only: Check and adjust carburetor for correct idle mixture and RPM.
12. Check for any deficiencies, malfunctions, signs of abuse, etc. Correction of any problems at this time will prevent the worsening of a minor problem and help ensure a trouble-free boating season.
13. Check oil level in Sterndrive and add as necessary with GL-5 Synthetic Gear Lubricant or Mobilube 1 SHC Fully Synthetic SAE

75W-90 (meeting or exceeding MIL-L-2105C or D, API GL-4 or 5) gear lubricant.

14. Make sure engine can achieve maximum rated RPM. See engine specifications.

## Belt Tension

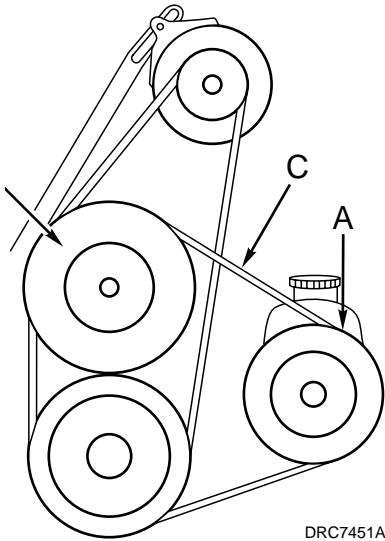

### Fuel Injected Models

#### Carbureted Models

- a. Power Steering Pump Belt
- b. Alternator Belt

With engine stopped, check belt tension half way between the crankshaft and the appropriate accessory pulley using one of the following methods:

- Use belt tension gauge to set tension to  $75 \pm 10$  lb. ( $33.6 \pm 44.5$  N).
- Use light thumb pressure and check for 1/4 in. (6.4 mm) belt deflection.

If belts are too tight, excessive belt and bearing wear can occur. If they are too loose, slippage can occur, resulting in belt wear; and poor circulating pump, alternator, supply pump or power steering operation. Tension of a new belt should be checked after 10 hours of service and every 50 hours thereafter.

Serpentine belts do not require tensioning. Replace when the tension indicator lines up with the single line on the housing.

## Alternator Belt Adjustment

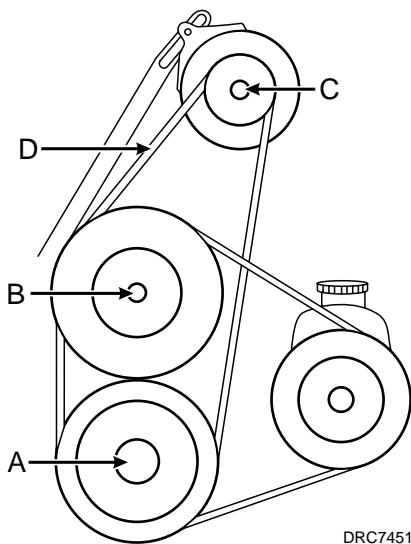

#### Carbureted Models

Check alternator belt tension midway between the circulating pump pulley and the alternator pulley.

- a. Crankshaft Pulley
- b. Circulating Pump Pulley
- c. Alternator Pulley
- d. Belt Tension Check Point
- e. Supply Pump Pulley

Check alternator belt tension (d) midway between the circulating pump pulley (b) and the alternator pulley (c).

1. Loosen alternator mounting screws and nuts, and pivot alternator away from engine to increase belt tension.
2. While maintaining pressure on alternator, retighten top screw, bottom screw and nut. Recheck belt tension.

**NOTE! The belts used for the alternator, circulating pump, and power steering pump are heavy-duty. DO NOT replace with automotive belts.**

## Power Steering Pump Belt Adjustment

#### Carbureted Models

- a. Power Steering Pump Pulley

- b. Circulating Pump Pulley
- c. Belt Tension Check point



**Caution!**

**Improper power steering belt adjustment will cause a loss of power steering assist, resulting in hard steering.**

Check power steering belt tension midway between the circulating pump pulley and the power steering pump pulley.

To increase belt tension: Loosen pump mounting bracket screws, insert a 1/2 in. breaker bar into the square hole in the pump mounting bracket, and pivot pump away from engine as shown. While maintaining pressure on pump, retighten all mounting screws. Recheck belt tension. Never pry against the pump reservoir or pull filler neck.

The belts used for the alternator, circulating pump, and power steering pump are heavy-duty. DO NOT replace with automotive belts.

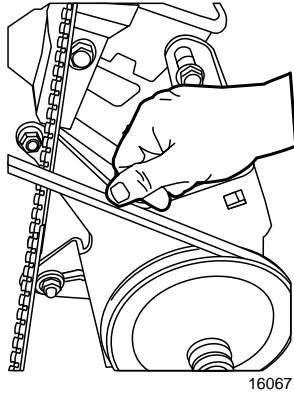

16067

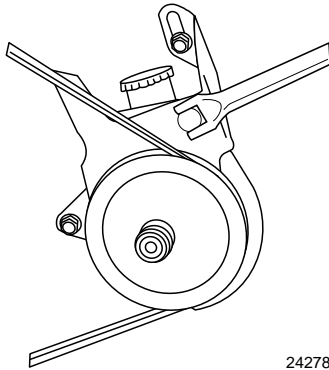

24278

## Positive Closed-Type Ventilation System

A malfunctioning closed crankcase ventilation system may be indicated by loping or rough engine idle. Do not attempt to compensate for this idle condition by disconnecting the crank-case ventilation system and making adjustments. The removal of the crankcase ventilation system from the engine will adversely affect fuel economy and engine ventilation with resultant shortening of engine life. To determine whether loping or rough idle condition is caused by a malfunctioning crankcase ventilation system, perform the following tests.

### With Engine Idling

1. Remove PCV valve from its mounting, but leave vacuum inlet side connected to hose. If the valve is functioning properly and not plugged, a hissing noise will be heard as air passes through valve. A strong vacuum will be felt when a finger is placed over valve inlet. Check for vacuum leaks in hose line and at all connections.
2. Reinstall PCV valve, then remove crankcase air inlet hose at flame arrestor connection. Loosely hold a small piece of stiff paper (such as a 3 x 5 memo card or parts tag card) over opening at end of inlet hose. After a minute or so, (to allow crankcase pressure to lower) the piece of paper should be sucked against hose opening with a noticeable force.



- With Engine Stopped** Remove PCV valve from its mounting and shake it. A metallic clicking noise should be heard, indicating that valve parts are free, and not sticking.
- If ventilation system passes these two tests, it can be considered functionally OK, and no further service is required. If it fails either test, replace PCV valve and repeat Engine Idling Test.
- If system still does not pass test, clean ventilation system hoses and all passages to induction system in accordance with established procedures.

**Servicing PCV Valve****Caution!**

**Do not attempt to clean crankcase ventilation regulator valve. It should be replaced.**

Clean crankcase ventilation system connection(s) on intake manifold by probing with a flexible wire or bottle brush. Clean hoses, tubes and associated hardware with a low-volatility, petroleum-base solvent and dry with compressed air.

## Troubleshooting - System Isolation

The following is to help you isolate a malfunction of one or possibly several systems. After determining which systems are related to the malfunction, refer to the individual system troubleshooting charts to isolate the specific cause.

## Engine Troubleshooting Guides

**Fuel Injected Engines Only: Refer to EFI Diagnostic Service Manual.**

These guides were written to help you trace the symptoms of the trouble to the source, without having to read through and prove every possibility. Much of the information here will be familiar to well informed mechanics.

Also, many factors will seem insignificant but when you think of it, usually the toughest problem to troubleshoot is caused by the smallest error. The greatest aid to solving a service problem is information. Start gathering information from the boat operator and write it on his job card or work ticket. Find out pertinent facts, such as:

- When did this trouble start?
- How was the boat loaded?
- Did the trouble occur suddenly, or start gradually?

Analyze this information and try to match it to similar situations you have experienced in the past. Keep in mind the fundamental rules:

- COMPRESSION - Mixture inducted into cylinder and compressed.
- SPARK - Proper intensity at the proper time.
- FUEL - Proper mixture of air and fuel.

These are very old rules, but necessary for the engine to run. Use these charts and the service information they refer to. Do not try to remember tolerances, settings, measurements, etc., as they are writ-

**Table 5: System Isolation**

|                        |   |
|------------------------|---|
| Engine Does not Start  | <p>Engine should crank at specified RPM. If not, check for</p> <ol style="list-style-type: none"> <li>1. Discharged or dead Battery</li> <li>2. Loose or corroded connections</li> <li>3. Cranking System Troubleshooting Chart in the Electrical Ignition/ Fuel Service Manual</li> </ol>  |
|                        | <p>Must have good spark at spark plugs. If not, check the:</p> <ol style="list-style-type: none"> <li>1. Distributor Cap</li> <li>2. Coil and spark plug leads</li> <li>3. Ignition timing</li> <li>4. Automatic spark advance</li> <li>5. Appropriate Ignition Troubleshooting Chart in the Electrical/Ignition/Fuel Service Manual.</li> <li>6. EFI Models: Refer to EFI Diagnostic Manual</li> </ol>   |
|                        | <p>EFI Models: Refer to EFI Diagnostic Manual</p> <p>Carbureted Models: Carburetor accelerator pump should squirt fuel into the Venturi when throttle is advanced. If not, check the:</p> <ol style="list-style-type: none"> <li>1. Fuel Tank, valves, and lines</li> <li>2. Fuel pump and filter</li> <li>3. Carburetor and Filter</li> <li>4. Boat Fuel System Troubleshooting Chart</li> <li>5. Carburetor Troubleshooting Chart</li> <li>6. Engine Fuel System Troubleshooting Chart</li> </ol> |
| Engine Runs Improperly | <p>Check the following:</p> <ol style="list-style-type: none"> <li>1. Compression</li> <li>2. Ignition system</li> <li>3. Fuel and carburetor and injection system</li> <li>4. Lubrication system</li> <li>5. Cooling System</li> <li>6. Sterndrive and propeller</li> <li>7. PCV Valve</li> <li>8. Engine Troubleshooting Guides</li> </ol>  |

ten in the service manual. Leave your mind free to analyze the problem.

Following is a list of the troubleshooting guides which may be found on the pages indicated.

|   |         |
|---|---------|
| Title .....                             | Page    |
| Engine Will Not Crank .....             | page 21 |
| Engine Cranks, But Will Not Start ..... | page 21 |
| Hard Starting - Cold Engine .....       | page 22 |

|   |         |
|---|---------|
| Hard Starting - Hot Engine . . . . .              | page 22 |
| Engine Runs Rough . . . . .                       | page 22 |
| Engine Noises and Vibrations . . . . .            | page 23 |
| Engine Overheats . . . . .                        | page 24 |
| Engine Dies Out . . . . .                         | page 24 |
| Engine Won't Reach Operating RPM . . . . .        | page 25 |
| Defective Engine Lubricating System . . . . .     | page 25 |
| Low Battery Voltage After Short Storage . . . . . | page 25 |

## Engine Will Not Crank

### Starter Circuit - Check:

- Battery condition: weak, dead, sulfated, bad cells
- Battery cables for loose or corroded connections
- Shorted or open ignition switch
- Starter motor and solenoid for shorts, grounds or open circuits
- Starter assist solenoid/starter relay
- Circuit breakers
- Wiring from battery to ignition switch
- See ***Electrical/Ignition/Fuel Service Manual***

## Engine Cranks, But Will Not Start

### Ignition Circuit - Check:

- Primary circuit wiring from ignition switch to ignition coil/ignition module
- Secondary circuit wiring from coil to spark plug
- Spark plugs for proper gap, fouling, burned electrodes, cracked or dirty insulator
- See ***Electrical/Ignition/Fuel Service Manual***
- Low battery voltage

### Fuel System - Check:

- Quantity and condition of fuel in boat tank
- Operation and flow capacity of boat anti-siphon valve
- Fuel tank vent is unrestricted
- Fuel tank pick-up screen is clean
- Correct diameter/unrestricted boat fuel lines
- Fuel shutoff and multiple tank valves are open and operating properly
- Fuel pump vent hose for signs of fuel or oil that would indicate a fuel pump failure.
- Fuel pump/relay/circuit breaker operation
- External fuel filter canister and carburetor filter
- Carburetor accelerator pump
- See ***Electrical/Ignition/Fuel System Service Manual***

**Cylinder Compression - Check**

- Conduct test following procedure in this section, and compare readings to Compression Limit Chart.

**Hard Starting - Cold Engine**

Ask these questions first:

**Has Engine Always Done This? Check:**

1. Carburetor choke operation and adjustment
2. Fuel lines for obstructions
3. For debris inside fuel tank
4. See *Electrical/Ignition/Fuel System Service Manual*

**Was Engine Used For A Long Time? Check:**

1. For clean external canister and carburetor fuel filters
2. Empty carburetor float bowl due to evaporation
3. Water in fuel due to condensation
4. Fuel quality deterioration
5. See *Electrical/Ignition/Fuel System Service Manual*

**Is This A New Condition? Check:**

1. Carburetor choke operation and adjustment
2. Carburetor accelerator pump
3. Fuel system for leaks, dirt, or obstructions
4. Engine timing and ignition system
5. See *Electrical/Ignition/Fuel System Service Manual*

**Hard Starting - Hot Engine**

Ask these questions first:

**Has Engine Always Done This? Check:**

1. Carburetor choke operation and adjustment
2. See *Electrical/Ignition/Fuel System Service Manual*

**Is This A New Condition? Check:**

1. Brand, type or octane of fuel
2. Spark plugs
3. Water in fuel
4. Condition of battery and cables
5. Starter motor for overheat damage

**Did Engine Refuse To Start After Being Run? Check:**

1. Ignition system primary circuit
2. Ignition coil(s)/ignition module
3. Engine timing
4. Carburetor choke operation and adjustment
5. See *Electrical/Ignition/Fuel System Service Manual*

**Engine Runs Rough**

If Fuel Injected, see *EFI Diagnostic Workshop Manual*

**If At Slow Speed - Check:**

1. Idle speed and idle mixture
2. Engine timing and spark plugs
3. Fuel pump pressure
4. Water or contaminants in fuel
5. Carburetor or manifold vacuum leak

6. Internal carburetor fuel leak
7. See **Electrical/Ignition/Fuel System Service Manual**

**If At High Speed - Check:**

1. Air leak on suction side of fuel system
2. Too low octane fuel
3. Ignition system secondary circuit
4. Engine timing
5. Wrong model or size carburetor, improper main jets or power valve, defective secondary fuel circuit, secondary vacuum diaphragm failure
6. External canister and carburetor fuel filters
7. Fuel pump pressure
8. Engine compression
9. Water or contaminants in fuel, water in cylinders
10. See General Information section and Electrical/Ignition/ Fuel System Service Manual

**Engine Noises and Vibrations****Valves - Hydraulic Lifters**

1. Rapping only when starting (oil too heavy for prevailing weather, varnish on lifter, oil needs to be changed)
2. Intermittent rapping (leakage at lifter check ball)
3. Idle noise (excessive leak down rate, faulty check ball seat)
4. Generally noisy (excessive oil in crankcase, stuck lifter plunger)
5. Loud noise at operating temperature (scored lifter plunger, fast leak down rate, oil viscosity too light for prevailing weather or operating temperatures)
6. See appropriate Engine section

**Ignition System (Ping or Knock)**

1. Improper tuning
2. Incorrect spark plug wire routing
3. Use higher octane fuel
4. See Electrical/Ignition/Fuel Service Manual

**Cooling System**

1. Supply pump
2. Loose belts, pulleys
3. See **Cooling System** section

**Mountings**

1. Loose, broken or worn engine mounts
2. Loose lag screws holding mounts to stringer

**Crankshaft Balancer or Flywheel**

1. Loose bolt(s)

**Alternator**

1. Loose pulley, worn bearings
2. Loose mounting bolts

**Sterndrive**

1. Failed Ujoints or gimbal bearing

2. Damaged internal drive components
3. Worn, bent or broken propeller hub or blades
4. Loose, worn or damaged engine coupler

**Engine Overheats - Check:**

1. Actual engine temperature by verifying with an accurate thermometer
2. Gauge operation and wiring circuit
3. Sending unit operation and wiring circuit
4. Supply pump, circulating pump and belt(s)
5. Water intake screens for blockage
6. Thermostat
7. Water supply hoses
8. Engine timing
9. Water leaks on pressure side of supply pump
10. Air leaks on suction side of supply pump
11. Engine compression

**Engine Dies Out**

**Loss Of, Or Out Of, Fuel - Check:**

1. Fuel gauge operation and wiring
2. Fuel level in tank
3. Water or debris in fuel
4. Fuel pickup tube and screen blockage
5. Fuel tank vent blockage
6. Plugged external canister or carburetor fuel filters
7. Air leak on suction side of fuel system
8. Fuel leak on pressure side of fuel system
9. Inoperative, restricted or incorrectly sized anti-siphon valve
10. Boat fuel lines too small in diameter
11. Fuel pump pressure and suction
12. Carburetor cleanliness and operation
13. See ***Electrical/Ignition/Fuel System Service Manual***

**Loss Of Ignition - Check:**

1. Primary and secondary ignition circuits
2. Ignition switch
3. Circuit breakers
4. Wiring between engine and dash
5. Main engine harness wiring
6. See ***Electrical/Ignition/Fuel Service Manual***

**Engine Stops Or Dies Out Due To Seizure - Check:**

1. Sterndrive for internal damage
2. Oil pressure gauge and crankcase oil level
3. Temperature gauge and cooling system operation

**Engine Won't Reach Operating RPM - Check:**

4. Internal engine components as required
1. Fuel type or octane
2. Propeller pitch or diameter, damaged blades, slipping hub
3. Crankcase oil volume
4. Marine growth on hull and drive
5. Wrong Sterndrive gear ratio
6. Operating at high altitude
7. Restricted carburetor air intake
8. Restricted exhaust outlets in engine, transom bracket or drive
9. Poor cylinder compression
10. Carburetor size and type correct for engine
11. Fuel pump pressure and vacuum
12. Boat overloaded, or load improperly placed
13. Engine overheating
14. Engine timing and ignition system operation
15. Remote control cables and linkage for proper attachment and travel

**Defective Engine Lubricating System****Engine Components - Check:**

1. Clogged or incorrect oil filter
2. Worn oil pump gears, cover or shaft
3. Worn or collapsed oil pump relief valve spring, or foreign material caught on valve seat
4. Oil pump relief valve plunger loose in cover
5. Damaged filter bypass grommet
6. Clogged oil pickup screen, broken tube or housing
7. Plugged crankshaft or blocked oil galleys
8. Dirty or defective hydraulic lifters, clogged push rod passages
9. Poor quality, incorrect viscosity or quantity of oil
10. Incorrect hose routing on remote filter systems
11. Water in crankcase oil from condensation, defective head gasket, oil cooler, or cracked manifold/block water passages

**Oil Pressure Warning System - Check:**

1. Oil gauge/warning horn operation and wiring
2. Engine temperature
3. Oil pressure gauge and warning horn sender operation and wiring

**Low Battery Voltage After Short Storage****Engine/Boat Components - Check:**

1. All electrical accessories including ignition circuit off
2. Disconnect main battery negative cable from battery

3. Connect ammeter or voltmeter in series between negative battery cable and negative battery post
  - Meter reading of "0" indicates no draw, test battery and charging system
  - Meter movement no matter how slight indicates draw from battery
4. Disconnect main engine harness 10-Pin Connector
  - Meter drops back to "0", problem caused by boat system, continue to isolate each boat electrical accessory until problem is found
  - Meter does not drop back to "0", problem caused by engine electrical system, continue to isolate each engine electrical accessory until problem is found
5. Repair or replace components as necessary



## Section 2: General Mechanical

|   |    |
|---|----|
| General Description .....                               | 27 |
| Cleanliness and Care .....                              | 28 |
| Use of RTV Sealer and Anaerobic Gasket Eliminator ..... | 28 |
| Replacing Engine Gaskets .....                          | 29 |
| Cylinder Bores .....                                    | 30 |
| Piston and Connecting Rod .....                         | 33 |
| Measuring Piston Pin to Piston Clearance .....          | 34 |
| Piston Selection .....                                  | 35 |
| Assembling the Piston and Connecting Rod .....          | 35 |
| Installing the Piston Rings .....                       | 36 |
| Camshaft Bearings .....                                 | 38 |
| Camshaft Bearing Removal .....                          | 38 |
| Camshaft Measurements .....                             | 38 |
| Cylinder Head .....                                     | 40 |
| Valve Grinding .....                                    | 42 |
| Valves and components .....                             | 43 |
| Crankshaft and Connecting Rod Bearings .....            | 43 |
| Thread Repair .....                                     | 46 |
| Special Tools .....                                     | 48 |



### Safety Warnings

Before working on any part of the engine, read the Safety section at the end of this manual.

Always use the correct fastener in the proper location. When you replace a fastener, use **ONLY** the exact part number for that application. The text will call out those fasteners that require replacement after removal. The text will also call out the fasteners that require thread lockers or thread sealant.

**UNLESS OTHERWISE SPECIFIED**, do not use supplement coatings (paints, greases, or other corrosion inhibitors) on threaded fasteners or fastener joint interfaces. Generally, such coatings adversely affect the fastener torque and the joint clamping force, and may damage the fastener.

When you install fasteners, use the correct tightening sequence and tightening specifications. Following these instructions can help you avoid damage to parts and systems.

### General Description

The engine repair information described in this section explains how to clean, inspect, and measure certain engine components. Use this section along with the proper engine repair section for the correct disassembly and assembly procedures. Engine specifications are found in

the back of engine repair section and will be referred to often in this section.

## Cleanliness and Care

An engine is a combination of many machined, honed, polished, and lapped surfaces with very close tolerances. Whenever valve train, cylinder head, crankshaft, piston, and connecting rod components are removed for service, they should be installed in their original location.

Anytime the flame arrestor is removed, the intake opening must be covered. This will protect against the entrance of foreign material which could follow the intake passage into the cylinder and cause extensive damage when the engine is started.

When any internal engine parts are serviced, care and cleanliness are important. Apply a liberal coating of engine oil to friction areas during assembly to protect and lubricate the surfaces during initial operation. Throughout this section, it should be understood that proper cleaning and protection of machined surfaces and friction areas is part of the repair procedure. This is considered standard shop practice even if not specifically stated.

## Use of RTV Sealer and Anaerobic Gasket Eliminator

Two types of sealants are commonly used in the engines covered by this manual. These are RTV sealer and anaerobic “gasket eliminator” sealer.

It is important that these sealers be applied properly and in the proper place to prevent oil leaks. **THE TWO TYPES OF SEALER ARE NOT INTERCHANGEABLE.** Use the sealer recommended in the procedure.

- RTV (Room Temperature Vulcanizing) sealer is used where a non-rigid part is assembled to a rigid part. Common examples are oil pans and valve rocker arm covers.
- Anaerobic gasket eliminator hardens in the absence of air. This sealer is used where two rigid parts (such as castings) are assembled together. When two rigid parts are disassembled and no sealer or gasket is readily noticeable, the parts were probably assembled using gasket eliminator.

### Using RTV Sealer

1. Do not use RTV in areas where extreme temperatures are expected, such as exhaust manifold or head gaskets, or where gasket eliminator is specified.
2. Use a rubber mallet to separate components sealed with RTV. Bump the part sideways to shear the RTV sealer. Bumping should be done at bends or reinforced areas to prevent distortion of parts. RTV is weaker in shear (lateral) strength than in tensile (vertical) strength.



### Caution

**Attempting to pry or pull components apart may result in damage to the part.**

3. Remove all gasket material from the part using a plastic or wood scraper. Use Loctite brand “Chisel Gasket Remover,” P/N 79040, or Permatex brand “Gasket Remover,” P/N 4MA, or equivalent.

Follow all safety recommendations and directions that are on the can. Do not use any other method or technique to remove gasket material from a part.

4. Do not use abrasive pads, sand paper or power tools to clean gasket surfaces. These methods of cleaning can damage the part. Abrasive pads also produce a fine grit that the oil filter cannot remove from the oil. This grit is abrasive and has been known to cause internal engine damage.
5. Apply RTV to one of the clean surfaces. Use a bead size as specified in the procedure. Run the bead to the inside of any bolt holes. Do not allow the sealer in any blind threaded holes, as it may prevent the bolt from seating properly or cause damage when the bolt is tightened.
6. Assemble components while RTV is still wet (within 3 minutes). Do not wait for RTV to skin over.
7. Torque bolts to specifications. Do not overtighten.

### Using Anaerobic Gasket Eliminator

1. Remove all gasket material from the part using a plastic or wood scraper. Use Loctite brand or Permatex brand "Gasket Remover," or equivalent. Follow all safety recommendations and directions that are on the can. Do not use any other method or technique to remove gasket material from a part.



#### Caution!

**Do not use abrasive pads, sand paper or power tools to clean gasket surfaces. These methods of cleaning can damage the part. Abrasive pads also produce a fine grit that the oil filter cannot remove from the oil. This grit is abrasive and has been known to cause internal engine damage.**

2. Apply a continuous bead of gasket eliminator to one flange. Surfaces to be resealed must be clean and dry.
3. Spread the bead evenly with your finger to get a uniform coating on the complete flange.
4. Assemble parts in the normal manner and torque immediately to specifications.



#### Caution!

**Anaerobic sealed joints that are partially torqued and allowed to cure more than five minutes may result in incorrect shimming of the joint.**

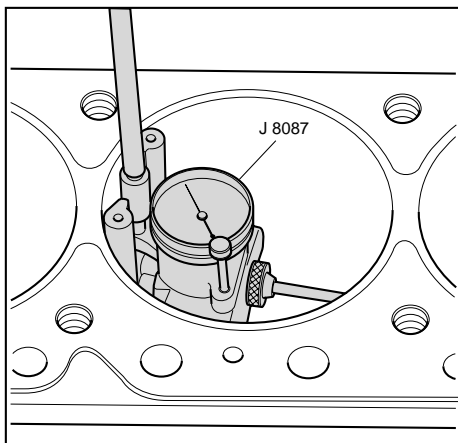

DRC6507

Composite-type head gaskets and intake manifold gaskets are used in the engine assembly. The head gaskets have a thin metal core. Some engine applications use a thin metal core for intake manifold gaskets. Use caution when removing or handling gaskets to help avoid personal injury.

## Cylinder Bores

### Measuring Cylinder Bore Taper and Out-of-Round

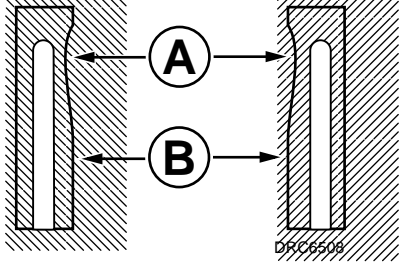

Tool Required: J 8087 Cylinder Bore Gauge

- If one or more cylinder bores are rough, scored or worn beyond limits, it will be necessary to smooth or true up such bores to fit new pistons.
- No attempt should be made to cut down oversize pistons to fit cylinder bores as this will destroy the surface treatment and affect the weight. The smallest possible oversize service pistons should be used and the cylinder bores should be honed to size for proper clearances.

1. Refer to **Engine Specifications** for cylinder bore tolerances.
2. Depress plunger on tool 0.03 in. (0,76 mm) or until tool enters cylinder bore.
3. Center the gauge in the cylinder and turn the dial to "0".
4. Carefully work the gauge up and down the cylinder to determine taper and turn it to different points around the cylinder wall to determine the out-of-round condition. Measure the bore both parallel to and at right angles to the engine centerline. Measure at the top, middle, and bottom of the bore and note the readings.
5. Recondition the cylinder bore as necessary. Refer to Cylinder Bore Reconditioning on page 31 in this section.

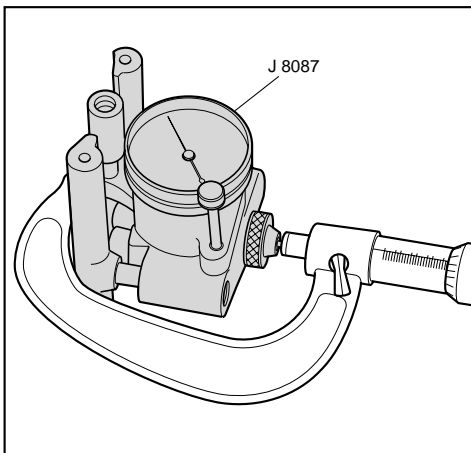

DRC6509

### Cylinder Bore Reconditioning

Measure:

1. Cylinder bore for out-of-round and taper.
2. Wear at the top of the bore (A) and the bottom (B). Refer to Engine Specifications in the proper engine repair section for cylinder bore tolerances.

Cylinder bores can be measured by setting the cylinder gauge dial at zero in the cylinder at the point of desired measurement. Lock the dial indicator at zero before removing it from the cylinder, and measure across the gauge contact points with an outside micrometer, with the gauge at the same zero setting when removed from the cylinder.

If cylinder bore taper or wear exceed specification, the cylinders must be bored and honed to the smallest oversize. Refer to **Engine Specifications** in the proper repair section.

Fine vertical scratches made by ring ends will not, by themselves, cause excessive oil consumption; therefore, honing to remove them is unnecessary.

If the bore is glazed but otherwise serviceable, break the glaze lightly with a hone and replace the piston rings. Refer to **Honing** on page 32 in this section.

If honing is not required, the cylinder bores should be cleaned with a hot water and detergent wash. Apply clean engine oil to the bore after cleaning.

## Removing Cylinder Bore Ridge

Tool Required: J 24270 Ridge Reamer

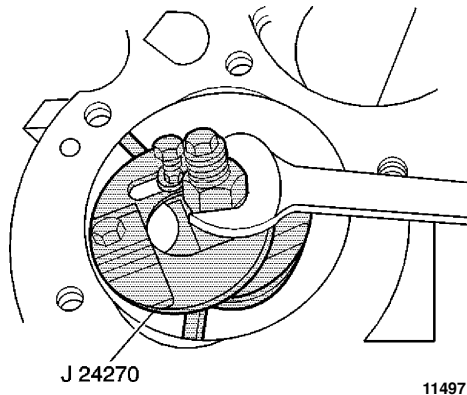
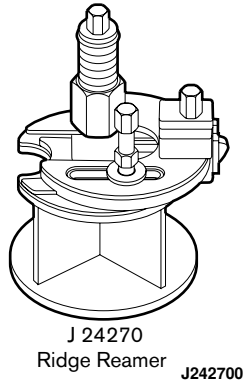

### Caution!

**Do NOT remove excessive material from the cylinder bore. Excessive removal of material may require cylinder boring to the next oversize.**

1. Rotate the crankshaft until the piston is at BDC.
2. Place a cloth on top of the piston.
3. Perform the cutting operation with a J 24270 ridge reamer. Refer to the manufacturer's instructions before using J 24270.
4. Remove J 24270 and rotate the crankshaft until the piston is at TDC.
5. Remove the cloth and cuttings.
6. Repeat this procedure for each piston.

### Boring

Refer to **Engine Specifications** on page 155 for additional information.

1. Before the honing or boring operation is started, measure all new pistons with the micrometer contacting at points exactly 90 degrees from the piston pin centerline. Some pistons must be measured at a specified distance from the piston crown. Refer to the proper section for additional instructions. Then select the smallest piston for the first fitting. The slight variation usually found between pistons in a set may provide for correction in case the first piston is fitted too loose.
2. Before using any type of boring bar, the top of the cylinder block should be filed to remove any dirt or burrs. This is very important. If not checked, the boring bar may be tilted which would result in the rebored cylinder wall not being at right angles to the crankshaft.
3. The instructions furnished by the manufacturer of the equipment being used should be carefully followed.
4. When boring cylinders, all crankshaft bearing caps must be in place and tightened to the proper torque to avoid distortion of bores in the final assembly.

5. When taking the final cut with a boring bar, leave 0.001 in. (0,025 mm) on the diameter for finish honing to give the required position to the cylinder clearance specifications. (The honing or boring operation must be done carefully so the specified clearance between pistons, rings, and cylinder bores is maintained).

### Honing

1. When honing the cylinders, follow the hone manufacturer's recommendations for use, cleaning, and lubrication during honing. Use only clean, sharp stones of the proper grade for the amount of material to be removed. Dull, dirty stones cut unevenly and generate excessive heat. When using coarse or medium grade stones, use care to leave sufficient metal so that all stone marks may be removed with the fine stones used for finishing to provide proper clearance.
2. Occasionally, during the honing operation, the cylinder bore should be thoroughly cleaned, and the piston selected for the individual cylinder checked for correct fit.
3. When honing to eliminate taper in the cylinder, make full strokes of the hone in the cylinder. Also check measurement at the top, middle, and bottom of the bore repeatedly.



### Caution!

**Handle the pistons with care and do not attempt to force them through the cylinder until the cylinder has been honed to the correct size. The piston can be easily distorted through careless handling.**

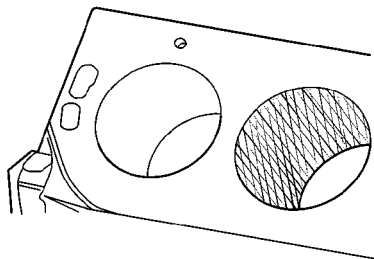

186747

4. When finish honing a cylinder bore to fit a piston, move the hone up and down at a sufficient speed to obtain very fine uniform surface finish marks in a cross-hatch pattern at the specified angle (45 to 65 degrees).
5. The finish marks should be clean but not sharp, free from embedded particles and torn or folded metal.
6. By measuring the piston to be installed at the sizing point specified in the proper section, and adding the average of the clearance specification, the finish hone cylinder measurement can be determined. It is important that both the block and piston be measured at normal room temperature. Refer to **Engine Specifications** on page 155 for proper dimensions
7. It is of the greatest importance that refinished cylinder bores are trued up to have less than the specified out-of-round or taper. Each bore must be final honed to remove all stone or cutter marks and provide a smooth surface.
8. 9. After final honing and before the piston is checked for fit, clean the bores with hot water and detergent. Scrub with a stiff bristle brush and rinse thoroughly with hot water. It is essential that a good cleaning operation be performed. If any of the abrasive material is allowed to remain in the cylinder bores, it will wear the new rings, cylinder bores, and bearings lubricated by the contaminated oil. After washing, the dry bore should be brushed clean with a power-driven fiber brush.
9. Refer to Engine Specifications in the proper engine repair section.

10. Permanently mark the piston for the cylinder to which it has been fitted.
11. Apply clean engine oil to each bore to prevent rusting.

## Piston and Connecting Rod

Tools Required: J 24086-C Piston Pin Removal and Installation Set

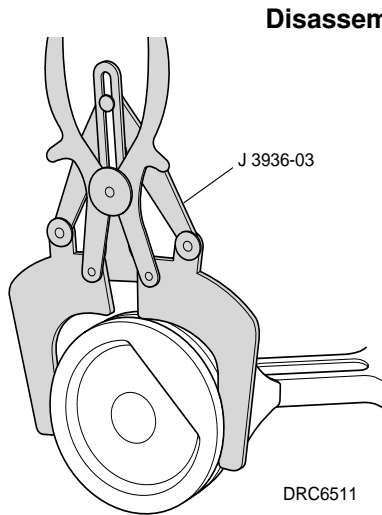

### Disassemble:

1. Piston rings. In most cases the rings should be discarded and replaced with new rings at assembly.
2. Connecting rod bearings. If the bearings are to be reused, place them in a rack so they may be reinstalled with the original connecting rod and cap.

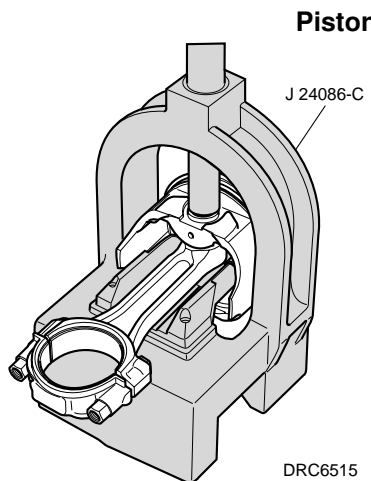

### Piston Pin

Place the piston/connecting rod on support fixture J 24086-C. Make sure the connecting rod is fully supported.

3. Place remover J 24086-C on the support fixture.
4. Press out the piston pin.
5. Cleaning and Inspection

### Clean:

- Piston
- Remove all varnish and carbon deposits. **DO NOT USE A WIRE BRUSH.**
- Use an approved cleaning solution to remove carbon build-up.
- Remove the carbon from the ring grooves. Use a ring groove cleaning tool.
- Oil-control ring groove holes.

### Inspect:

1. Piston pin bore and connecting rod bore for scuffing and burrs.
2. Connecting rod for cracks, nicks, etc. If a suitable jig is available, check the connecting rod for a bent or twisted condition.
3. Connecting rod bearings for scratches or deep pitting.
4. Piston for:

- Scratches, scuffing, and burrs
- Ring land for cracking and wear
- Ring grooves for burrs and nicks
- Skirts and pin bosses for cracking
- Skirts for scuffing

## Measuring Piston Pin to Piston Clearance

### Measure:

#### Piston pin diameter

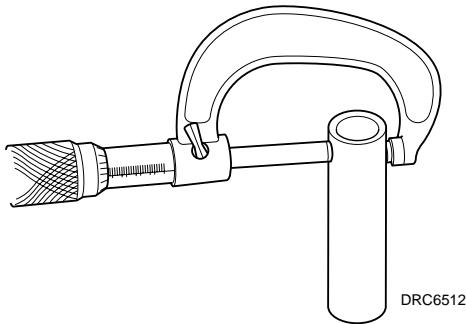

1. Check against Engine Specifications in the proper engine repair section.

#### Piston pin to piston clearance

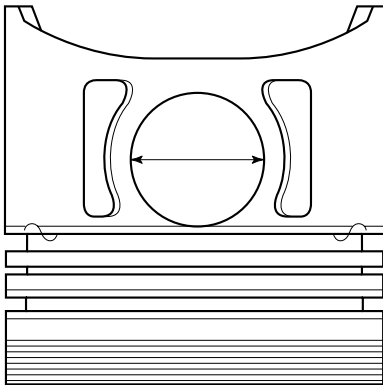

2. Measure the piston pin hole diameter.
3. Subtract the piston pin diameter from the piston pin hole diameter to obtain the clearance.
4. Replace the piston and piston pin if the clearance exceeds specifications. The piston and piston pin are a matched set and not available separately.



## Piston Selection

Check the used piston to cylinder bore clearance.

### Measure:

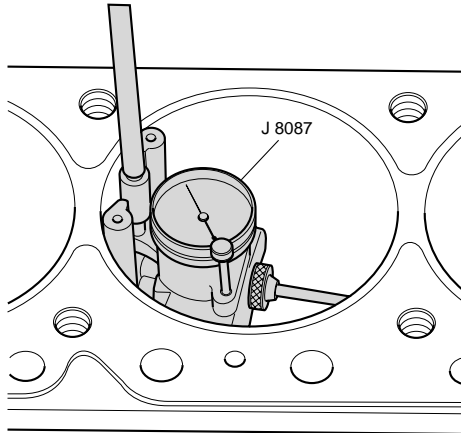

DRC6507

1. Cylinder bore diameter. Use a telescoping bore gauge, located 2.56 in. (65 mm) below the top of the cylinder bore.
2. Piston diameter. Measure the piston skirt at a right angle to the piston pin, at the centerline of the piston pin.
3. Subtract the piston diameter from the cylinder bore diameter to determine piston to bore clearance.
4. Refer to Engine Specifications in the proper engine repair section to determine if piston clearance is within the acceptable range.

If the used piston is not acceptable, determine if a new piston will fit the cylinder bore. If a new piston does not bring the clearance within tolerances, the cylinder bore must be reconditioned. Mark the piston to identify the cylinder for which it was fitted.

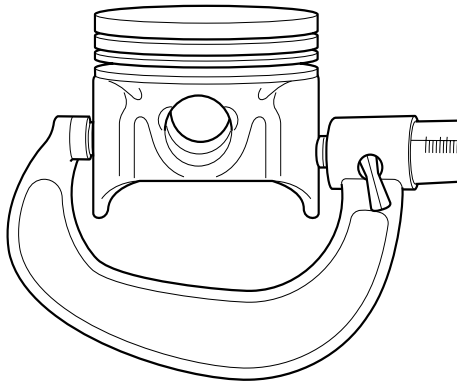

DRC6514

## Assembling the Piston and Connecting Rod

Tool Required: J 24086-C Piston Pin Removal and Installation Set

**Assemble:**

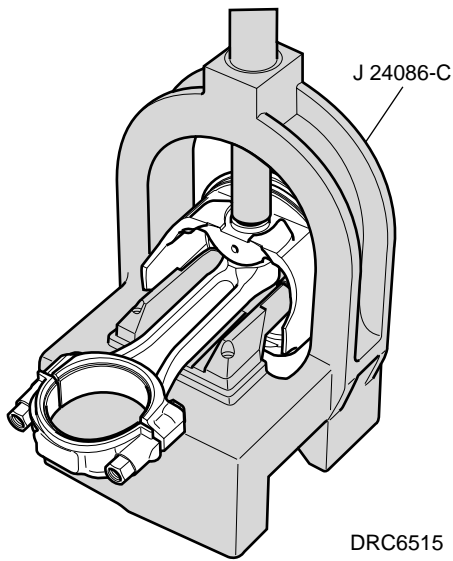

1. Piston and connecting rod.
  - The alignment mark on the top of the piston must face the front of engine block. Connecting rod must be installed in the correct orientation. Refer to the proper engine repair section for piston and connecting rod installation.
  - Lubricate the piston pin holes in the piston and connecting rod with engine oil.
- c. Install the pin guide. Hold the piston and connecting rod together. Be sure to use the proper pin guide. Refer to the instructions supplied with the tool.
2. Piston pin:
  - a. Insert the piston pin into the piston pin hole.
  - b. Place the assembly on the support fixture.
  - c. Adjust the piston pin installer (J 24086-C) to the correct length, using the letter-number scale on the installer adjuster. This is necessary to ensure the piston pin is pressed into the piston to the correct depth. Refer to the instructions supplied with the tool for the proper setting.
  - d. Lock the adjuster in place with the lock ring.

After the installer hub bottoms on the support assembly, do not exceed 5000 PSI (35,000 kPa) pressure, as this could cause damage to the tool.

- e. Place the adjuster in the support fixture. Press the piston pin into place (until the adjustable installer bottoms in the support fixture).
- f. Remove the piston and connecting rod assembly from the tool and check the piston for freedom of movement on the piston pin.

## Installing the Piston Rings

**Measure:**

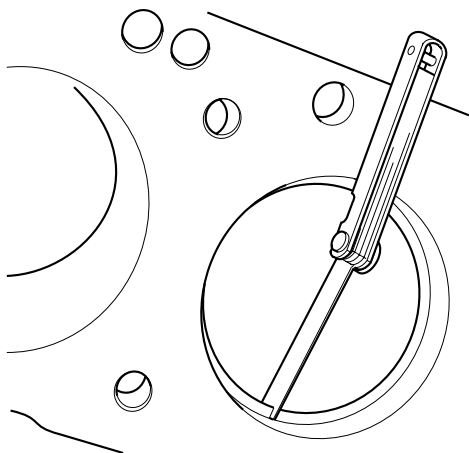

Ring end gap as follows:

1. Select rings comparable in size to the piston being used.
2. Slip compression ring into the cylinder bore.
3. Use piston to square ring in cylinder wall. Insert piston without rings upside down and guide the compression ring into the cylinder bore until ring is down about 1.499 in. (38,1 mm) below ring travel.
4. Space or gap between the ends of the ring with a feeler gauge.
5. Refer to Engine Specifications in the proper engine repair section for correct gap.
6. If the gap between the ends of the ring is not as specified, remove the ring and try another for fit.

DRC6516

**Inspect:** Ring fit as follows:

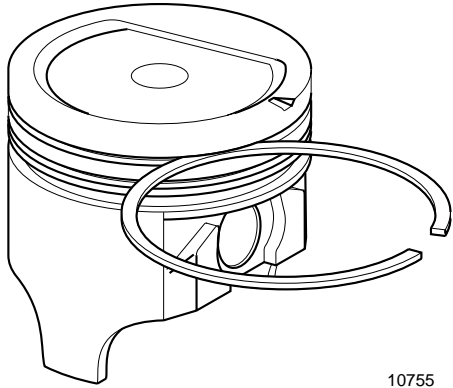

10755

1. Fit each compression ring to the piston on which it is going to be used.
2. Slip the outer surface of the top and second compression ring into the respective piston ring groove, to make sure the ring is free. If binding occurs at any point, the cause should be determined. If binding is caused by the ring groove, correct it by dressing the groove with a fine cut file. If the binding is caused by a distorted ring, try a new ring.

**Assemble:** Refer to Piston Assembly in the engine repair section.

All compression rings are marked on the upper side of the ring. When installing the compression rings, make sure the MARKED SIDE IS TOWARD THE TOP OF THE PISTON.

The oil control rings are 3-piece assemblies, consisting of two rails and an expander.

- Expander
- Lower rail
- Upper rail
- Lower compression ring
- Upper compression ring

Flex all rings to make sure they are free. If binding occurs at any point the cause should be determined. If binding is caused by the ring groove, correct it by dressing the groove with a fine cut file. If binding is caused by a distorted ring, try a new ring.

- Ring gaps must be 180 degrees apart
- Rail gaps must be 180 degrees apart

- Measure:**
1. Ring clearance. Use a feeler gauge.
  2. Compare with Engine Specifications in the proper engine repair section.

## Camshaft Bearings

### Camshaft Bearing Removal

**Disassemble:** Tool Required: J 33049 Camshaft Bearing Removal and Installation Set

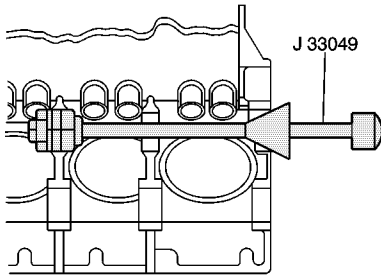

DRC6518

1. Rear camshaft plug.
2. All camshaft bearings. Use J 33049.
  - a. Insert the tool with the correct collet into the camshaft bearing you want to replace.
  - b. Turn the tool until the collet has tightened in the bearing.
  - c. Push the center cone against the block and into the first bearing bore to center the tool.
  - d. Drive the bearing from the block.
  - e. Repeat this procedure to remove the remaining inner camshaft bearings. Note that the rear bearing must be removed from the front of the block and the front bearing should be removed from the rear. This allows the tool to remain centered.

### Cleaning and Inspection

**Clean:**

- Camshaft bearing bores in the block.

**Inspect:**

- Camshaft bearings for scratches, pits, or loose fit in their bores. Replace the camshaft bearings if necessary.
- Camshaft lobes and journals for scratches, pitting, scoring, and wear. Minor irregularities may be cleaned up with emery cloth.

### Camshaft Measurements



Tool Required: J 7872 Dial Indicator or Equivalent

**Caution!** Whenever the camshaft needs to be replaced, a new set of valve roller lifters must also be installed.

- Measure:**
1. Camshaft journal diameters using a micrometer. Compare with Engine Specifications in the proper engine repair section.
  2. Camshaft runout. Mount the camshaft in V-blocks or between centers. Using J 7872, check the intermediate camshaft journal. Compare camshaft runout specifications in the proper engine repair section. If the camshaft is excessively bent, replace the camshaft and camshaft bearings.

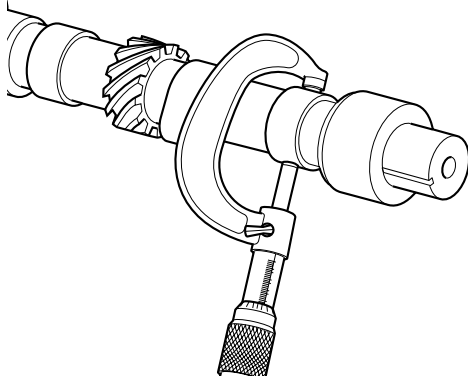

DRC6519

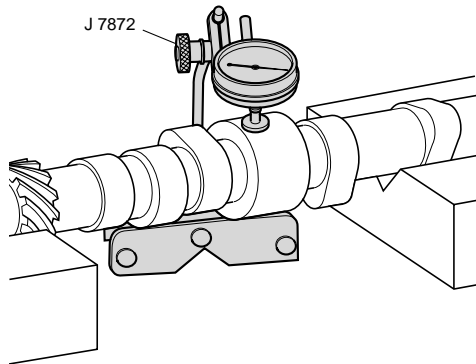

DRC6520

**Camshaft Bearing Installation Tool**

Required: J 33049 Camshaft Bearing Removal and Installation Set  
 The outer camshaft bearings must be installed first. These bearings serve as guides for the tool, and help center the inner bearings during the installation process.  
 Make sure to fit the correct cam bearing into the bore. The cam bearing bores may vary in size.

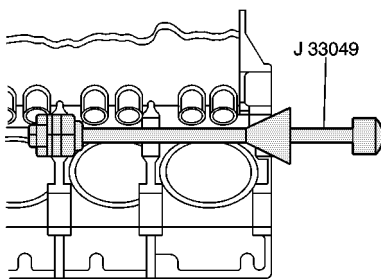

DRC6518

- Assemble:**
1. Rear camshaft bearings. Drive the bearings into place using J 33049 from front of engine.



**Caution!**

**Make sure the camshaft bearing lubrication hole (or holes) align with the oil gallery hole (or holes) in the block. On some engines, the oil holes may be difficult to see. Verify the holes are lined up.**

2. Front camshaft bearing using tool J 33049.

3. Inner camshaft bearings using J 33049. Reverse of removal procedure.
4. Camshaft rear plug.
  - a. Coat a new camshaft plug with *GM Sealer*, P/N 12345493, or equivalent.
  - b. Install the plug. The plug must be installed deep enough in camshaft bore. Refer to the proper engine repair section for camshaft plug installation.

## Cylinder Head

**Disassemble** Valves and components. Refer to the proper engine repair section.

**Cleaning and Inspection** Tools Required: J 8089 Wire Brush

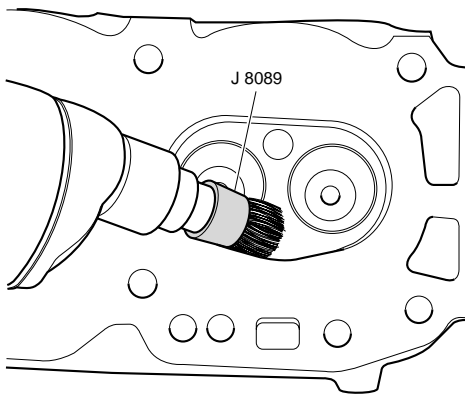

DR3123

- Clean**
1. Carbon from the combustion chambers, using J 8089.
  2. Valve stems and heads on a wire wheel.
  3. Carbon and old gasket from the cylinder head gasket surface.
  4. Valve guides using a valve guide cleaner.

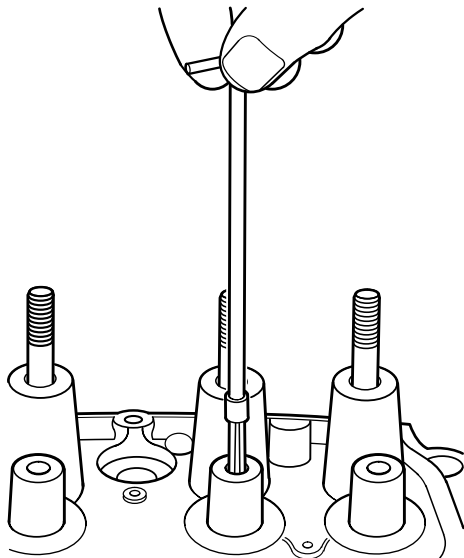

DR3124

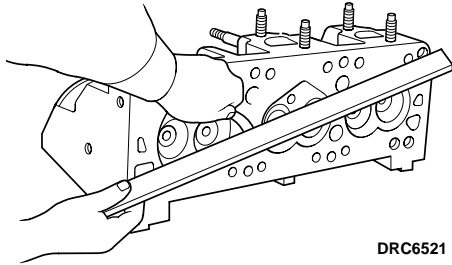
**Inspect**

DRC6521

1. Cylinder head for cracks in the exhaust ports, combustion chambers, or external cracks to the coolant chamber. Gasket surfaces should be free of damage.
2. Check valves for burning, pitting, or warping. Grind or replace as needed. See "Valve Grinding" on page 42 in this section. Check the valve stems for scoring or excessive wear. Stems must not be bent.
3. Valve rocker arm studs for wear, damage, or improper fit.
4. Valve seats for pitting or other damage. Grind or reface as needed.
5. Rotators (if used). The rotators should rotate smoothly without binding.
6. Cylinder head for surface flatness.

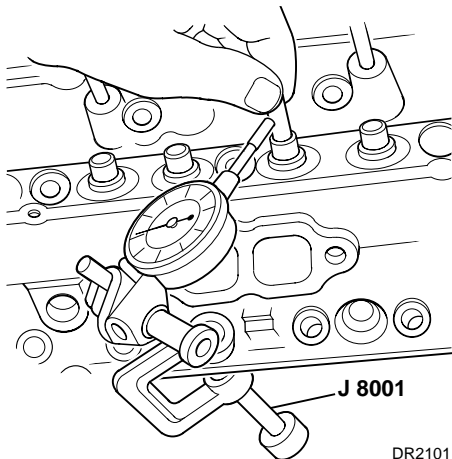
**Measure:**

DR2101

Tools Required: J 8001 Dial Indicator or equivalent, J 9666 Valve Spring Tester

1. Valve stem to guide bore clearance.
  - a. Excessive valve stem to guide bore clearance will cause excessive oil consumption and may damage components. Insufficient clearance will result in noisy and sticky functioning of the valve and interfere with engine smoothness.
  - b. Clamp a dial indicator J 8001 or equivalent on one side of the cylinder head valve rocker arm cover gasket rail.
  - c. Observe dial indicator movement while moving valve from side to side (crosswise to the head). The dial indicator measurement must be taken just above the valve guide bore.
  - d. Drop the valve head about 0.063 in. (1,6 mm) off the valve seat.
  - e. Move the stem of the valve from side to side using light pressure to obtain a clearance reading. If clearance exceeds specifications, it will be necessary to ream the valve guide bores for oversize valves as outlined later.
2. Valve spring tension, using J 9666 or equivalent.
  - a. Compress the valve springs to the specified height. Check valve spring height in Engine Specifications in the proper engine repair section. Valve springs should be replaced if not within specification.

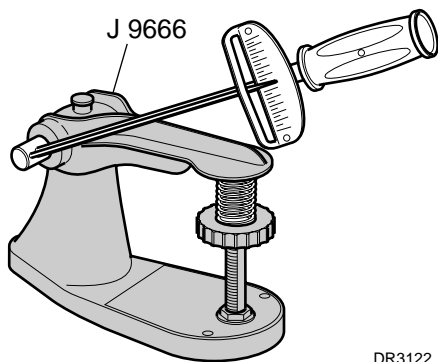

DR3122

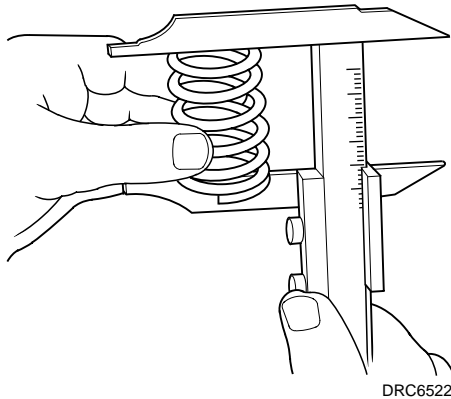

- b. Valve spring length. Replace the valve spring if valve spring length exceeds specifications. Refer to Engine Specifications in the proper engine repair section.

**Repair**

**Valve Grinding**

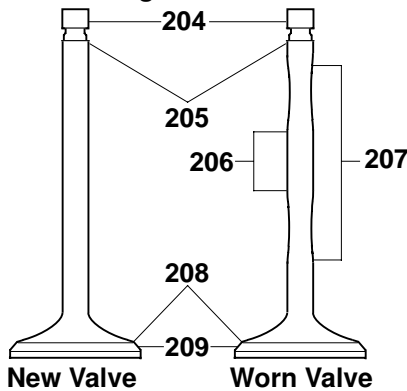

Pitted valves must be re-faced to the proper angle. Valve stems that show excessive wear, or valves that are warped excessively must be replaced. When an excessively warped valve head is refaced, a sharp or thin valve margin may result because of the amount of metal that must be removed. Undersize valve margins lead to breakage, burning, or preignition due to heat localizing on this edge. Refer to Engine Specifications in the engine repair section.

Several different types of equipment are available for refacing valves. The manufacturer's instructions for how to use the equipment should be carefully followed to achieve proper results. Refer to Engine Specifications in the proper engine repair section for valve face angle specifications.

- 204 Valve Tip
- 205 Key Groove
- 206 Stem-Least Worn
- 207 Stem- Most Worn
- 208 Face
- 209 Margin

**Valve Seat Grinding**

Reconditioning the valve seats is very important, because the seating of the valves must be perfect for the engine to deliver the power and performance it was designed to produce.

Another important factor is the cooling of the valve head. Good contact between each valve and its seat ensures that heat will be carried away properly.

Several different types of equipment are available for resurfacing valve seats. Carefully follow the recommendations of the manufacturer of the equipment being used to attain proper results.

Regardless of what type of equipment is used, it is essential that valve guide bores be free from carbon or dirt to ensure proper centering of the pilot in the guide. Refer to Engine Specifications in the proper engine repair section for valve seat angle specifications.



### Reaming Valve Guides

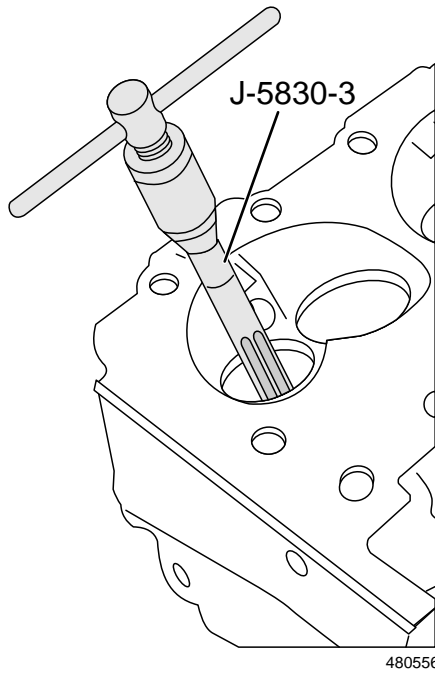

The valve guides used in engines covered by this manual are simply holes bored into the cylinder head. The valve guides are not replaceable.

If the valve stem-to-bore clearance as previously measured is excessive, the valve guides should be reamed and a valve with an oversize stem installed. Oversize valves are available. Refer to Engine Specifications in the proper engine repair section.

Select a reamer that will provide a straight, clean bore through the entire length of the valve guide.

### Assembly

### Valves and components

Refer to the proper engine repair section.

#### Measure:

Valve spring installed height of each valve spring as follows:

Valve installed height using a narrow thin scale. A cutaway scale (A) may be helpful.

Spring seat in the cylinder head to the top of the valve spring cap.

Certain engine applications use valve spring shims to adjust valve spring installed height. If measurement exceeds the amount shown in Engine Specifications in the engine repair section, install valve spring seat shims of sufficient thickness (between the spring and cylinder head) to obtain desired measurement. NEVER shim the spring so as to give an installed height under the specified amount.

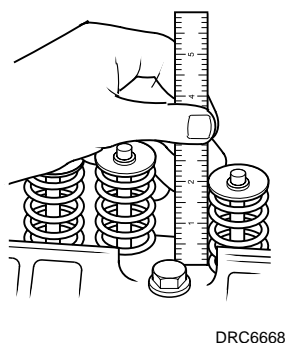
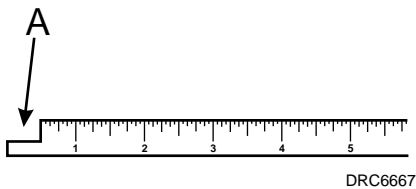

## Crankshaft and Connecting Rod Bearings

### Cleaning and Inspection

#### Clean:

1. Crankshaft with solvent.
  - Do not scratch the bearing journals
  - Remove all sludge from the oil passages with compressed air
2. Crankshaft bearings.

- Wipe free of oil with a soft cloth.

**Inspect:** Crankshaft for cracks.

- Use the magnaflux method if available.
- Crankshaft, crankshaft bearing journals, and thrust surfaces for scoring, nicks, or damage caused by lack of lubrication.
- Crankshaft bearings for scoring or other damage. In general, the lower crankshaft bearings (except the #1 bearing) show the greatest wear and distress from fatigue. Upon inspection, if a lower crankshaft bearing is suitable for reuse, it can be assumed that the upper crankshaft bearing is also satisfactory. If a lower crankshaft bearing shows evidence of wear or damage, both the upper and lower crankshaft bearings must be replaced.

### Measuring Bearing Clearance

Crankshaft bearings are of the precision insert type and do not use shims for adjustment. If clearances are excessive, new upper and lower bearings will be required. Service bearings are available in standard size and undersize. Refer to Crankshaft and Bearing Installation in the proper engine repair section.

Selective fitting of crankshaft bearings are necessary in production to obtain close tolerances. For example, you may find one-half of a standard crankshaft bearing with one-half of an undersize crankshaft bearing.

To determine the correct replacement bearing size, the bearing clearance must be measured accurately. Either of the following two methods may be used, however, the micrometer method gives more reliable results and is preferred.

#### Micrometer Method

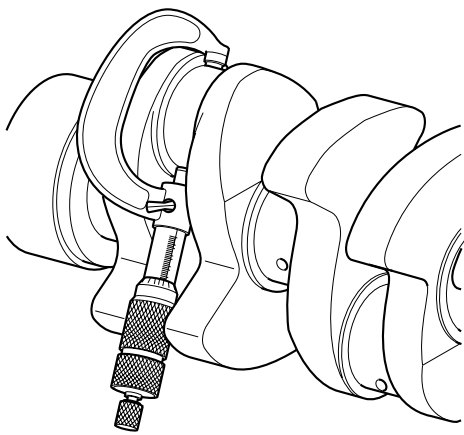

DRC6525

1. Measure the crankshaft journal diameter with a micrometer in several places, approximately 90 degrees apart, and average the measurements.
2. Compute taper and runout. Refer to Engine Specifications in the proper engine repair section for allowable limits.
3. Install crankshaft bearings into the crankshaft cap and engine block.
4. Install crankshaft caps and bolts. Tighten bolts to the Torque Specifications in the proper engine repair section.
5. Bearing inside diameter (I.D.) using an inside micrometer.
6. Compare crankshaft bearing clearance specifications using Engine Specifications in the proper engine repair section.
7. If bearing clearances exceeds specifications, install new crankshaft bearings.
  - a. Measure inside diameter with an inside micrometer. Place the micrometer at 90 degrees to the split line of the crankshaft bearing.
  - b. Subtract journal diameter from bearing inside diameter to obtain bearing clearance. Refer to Engine Specifications in the proper engine repair section for bearing inside clearance. Replace or repair the crankshaft if clearance exceeds specifications.

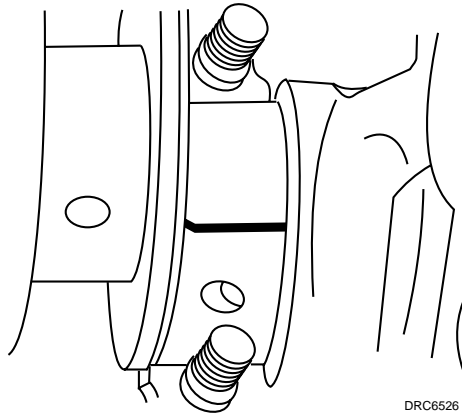
**Plastic Gauge Method**

DRC6526

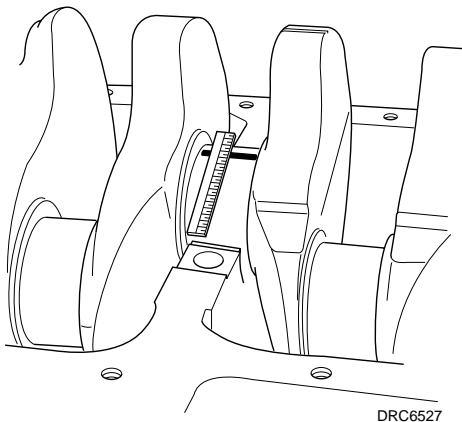

DRC6527

Install all crankshaft bearings and crankshaft into block.

1. Install the crankshaft bearing caps and torque them to specifications. Remove the bearing caps and check the amount the gauging plastic has been compressed. Gauging plastic may adhere to either the crankshaft bearing or crankshaft journal.
2. On the edge of the gauging plastic envelope there is a graduated scale. Without removing the gauging plastic, measure its compressed width (at the widest point).
3. If the flattened gauging plastic tapers toward the middle or ends, there is a difference in clearance indicating taper, low spot or other irregularity of the bearing or journal.
4. Normally crankshaft bearing journals wear evenly and are not out-of-round. However, if a bearing is being fitted to an out-of-round 0.001 in. (0.0254 mm) maximum journal, be sure to fit to the maximum diameter of the journal. If the bearing is fitted to the minimum diameter and the journal is excessively out-of-round, interference between the bearing and the journal will result in rapid bearing failure.
5. If the bearing clearance is within specifications, the bearing is satisfactory. If the clearance is not within specifications, replace the bearing. Always replace both upper and lower bearings as a unit.
6. A standard or underside bearing combination may result in the proper clearance. If the proper bearing clearance cannot be achieved using standard or underside bearings, it will be necessary to replace the crankshaft.

**Caution!**

**Crankshaft bearings must not be shimmed, scraped or filed. Do not touch the bearing surface with bare fingers. Skin oil and acids will etch the bearing surface.**

7. Remove the flattened gaging plastic.
8. Measure remaining journals.

**Crankshaft Runout**

Tools Required: J 7872 Magnetic Base Dial Indicator

**Measure:**

Crankshaft

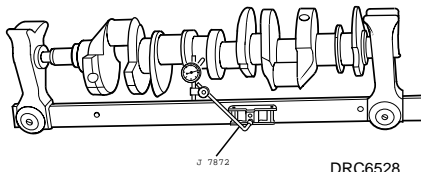

J 7872

DRC6528

1. Mount the crankshaft in V-blocks at crankshaft journals 1 and 5.
2. Position a dial indicator pointer on the center main bearing and rotate crankshaft.
3. Refer to Engine Specifications in the proper engine repair section for crankshaft runout specifications.

### Connecting Rod Side Clearance

**Measure:** Connecting rod side clearance. Refer to Engine Specifications in the proper engine repair section for clearance.

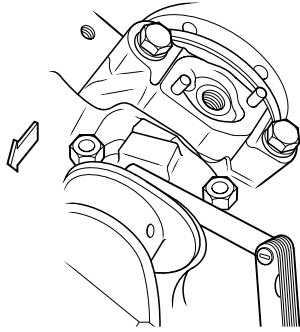

DRC6529

### Crankshaft End Play

**Measure:** Crankshaft end play, as follows:

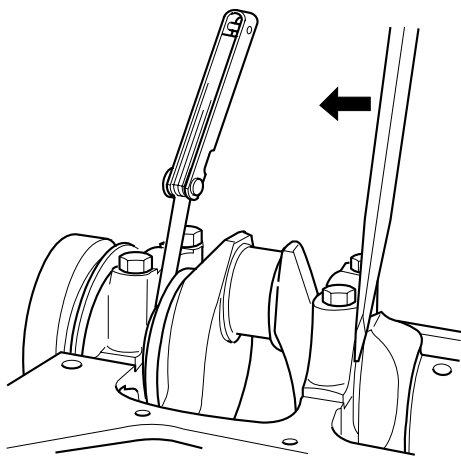

DRC6530

1. Firmly thrust the end of the crankshaft first rearward then forward. This will line up the rear crankshaft bearing and crankshaft thrust surfaces.
2. With crankshaft wedged forward, measure at the front end of the crankshaft bearing (thrust side) with a feeler gauge. Refer to Engine Specifications in the proper engine repair section for crankshaft end play clearance.
3. If correct end play cannot be obtained, be certain that the correct size crankshaft bearing has been installed. Some production engines may use crankshaft bearings that are wider across the thrust faces than standard size bearings. Refer to Engine Specifications in the proper engine repair section for available bearing sizes.

**Inspect:** Crankshaft for binding. Turn crankshaft to check for binding. If the crankshaft does not turn freely, loosen the crankshaft bearing bolts, one pair at a time, until the tight bearing is located. Burrs on the bearing cap, foreign matter between the bearing and the block or the bearing cap, or a faulty bearing could cause a lack of clearance at the bearing.

## Thread Repair

Damaged threads may be reconditioned by drilling out, rethreading, and installing a suitable thread insert.



**Warning! Wear safety glasses to avoid eye damage.**

1. Determine size, pitch, and depth of damaged thread. If necessary, adjust stop collars on cutting tool and tap to required depth.

**Note! Refer to the kit manufacturer's instructions regarding the size of drill and tap to be used.**

2. Drill out damaged thread. Clean out chips.

3. Lubricate tap with light engine oil. Tap hole. Clean the thread.

**Note! Avoid buildup of chips. Back out the tap every few turns and remove chips.**

4. Thread the thread insert onto the mandrel of the installer. Engage the tang of the insert onto the end of the mandrel.
5. Lubricate the insert with light engine oil (except when installing in aluminum) and install.

**Note! When correctly installed, the insert should be flush to one turn below the surface.**

6. If the tang of the insert does not break off when backing out the installer, break the tang off with a drift.

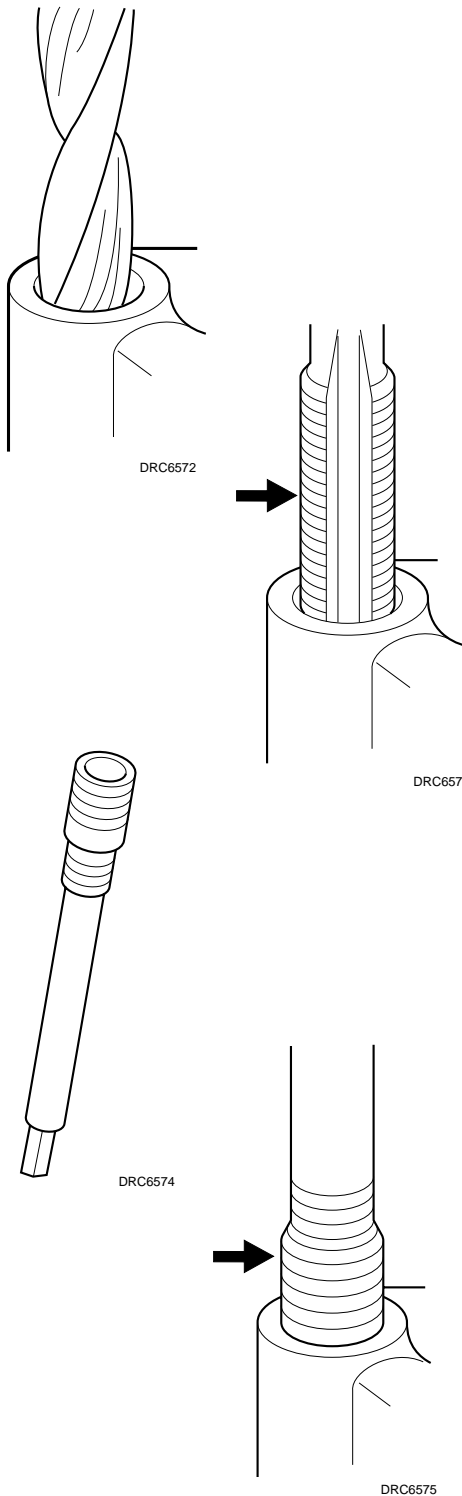

## Special Tools

Cylinder Bore Gauge

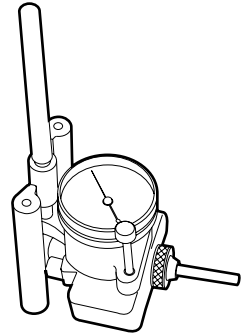

Piston Pin Replacer Set

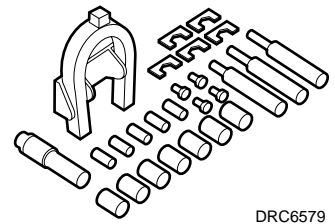

DRC6579

Camshaft Bearing Remover / Installer

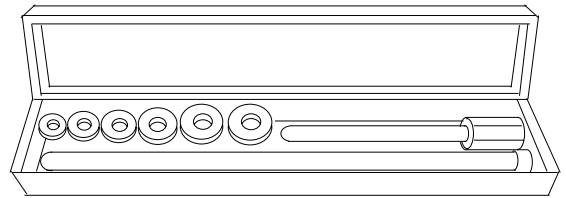

J33049

Wire Brush



Dial Indicator

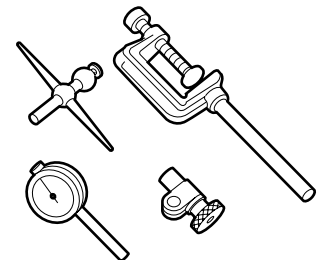

**Valve Spring Tester**

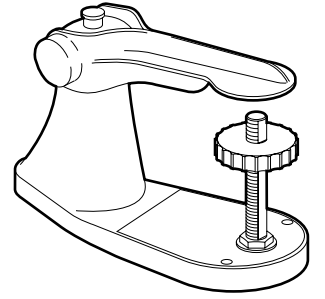

**Ridge Reamer**

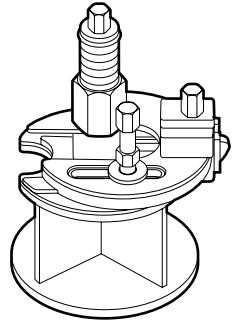

# NOTES

A series of horizontal dashed lines for writing notes.



## Section 3: Engine — 5.0 & 5.7 Liter

|  |    |
|--|----|
| General Description .....                                | 52 |
| Tools and Shop Equipment .....                           | 53 |
| Accessories .....  | 53 |
| Cleaning .....   | 54 |
| Draining The Engine .....                                | 54 |
| Engine Lubrication .....                                 | 54 |
| Exhaust Manifold .....                                   | 55 |
| Starter .....  | 57 |
| Intake Manifold .....                                    | 58 |
| Remove Distributor .....                                 | 60 |
| Disassemble Intake Manifold (GX <sub>i</sub> only) ..... | 63 |
| Assemble Intake Manifold .....                           | 65 |
| Intake Manifold Installation .....                       | 66 |
| Distributor Installation .....                           | 68 |
| Rocker Arm Cover .....                                   | 73 |
| Valve Train .....  | 73 |
| Valve Lifters and Guides Clean and Inspect .....         | 76 |
| Valve Lifter Installation .....                          | 77 |
| Valve Lifter Pushrod Guides .....                        | 77 |
| Valve Push Rod .....                                     | 78 |
| Install Rocker Arm Assemblies .....                      | 78 |
| Valve Lash Adjustment .....                              | 78 |
| Valve Rocker Arm Cover Installation .....                | 80 |
| Cylinder Head .....                                      | 80 |
| Cylinder Head Disassemble and Recondition .....          | 81 |
| Cylinder Head Clean and Inspect .....                    | 82 |
| Valve Spring Straightness .....                          | 84 |
| Valve Stems .....  | 84 |
| Valve Guide Reaming and Seat Grinding .....              | 85 |
| Valve Rocker Arm Stud Removal .....                      | 87 |
| Valve Rocker Arm Stud Installation .....                 | 87 |
| Cylinder Head Assemble .....                             | 88 |
| Install Oil Seal .....                                   | 88 |
| Oil Pan and Oil Pump .....                               | 92 |
| Oil Pan Clean and Inspect .....                          | 93 |
| Oil Pump Disassemble .....                               | 94 |

|   |     |
|---|-----|
| Oil Pump Clean and Inspect .....                | 96  |
| Water Pump .....                                | 100 |
| Water Pump Installation .....                   | 103 |
| Crankshaft Balancer .....                       | 104 |
| Crankshaft Balancer Inspect .....               | 106 |
| Crankshaft Balancer Installation .....          | 106 |
| Engine Front Cover .....                        | 108 |
| Engine Front Cover Installation .....           | 109 |
| Timing Chain and Sprocket .....                 | 110 |
| Camshaft .....                                  | 114 |
| Camshaft Bearings .....                         | 117 |
| Piston, Connecting Rod, and Bearings .....      | 121 |
| Piston and Connecting Rod Disassemble .....     | 123 |
| Clean and Inspect .....                         | 124 |
| Piston Selection .....                          | 127 |
| Engine Coupler .....                            | 132 |
| Flywheel .....                                  | 135 |
| Crankshaft Rear Oil Seal and Housing .....      | 136 |
| Crankshaft .....                                | 139 |
| Crankshaft and Bearings Clean and Inspect ..... | 141 |
| Measuring Crankshaft Bearing Clearances .....   | 144 |
| Micrometer Method for Crankshaft Bearings ..... | 144 |
| Recondition Engine Block .....                  | 149 |
| Engine Block Plug .....                         | 149 |
| Engine Block Clean and inspect .....            | 152 |
| Cylinder Boring and Honing .....                | 153 |
| Boring Procedure .....                          | 154 |
| Engine Specifications .....                     | 155 |
| Tune Up Specifications .....                    | 161 |

## General Description

- Cylinder Block** The engine block is made of cast iron and has eight cylinders arranged in a “V” shape with four cylinders in each bank. It is a one piece casting with the cylinders encircled by coolant jackets.
- Cylinder Head** The cylinder heads are cast iron. The valve guides and valve seats are machined surfaces integral to the head. The spark plugs are located between the intake and exhaust ports.
- Camshaft** A steel camshaft is supported by five bearings pressed into the engine block. The camshaft sprocket, mounted to the front of the camshaft is

driven by the crankshaft sprocket through a camshaft timing chain. Motion from the camshaft is transmitted to the valves by hydraulic roller valve lifters, valve push rods, and ball-pivot type rocker arms.

**Crankshaft** The crankshaft is made of cast nodular iron. It is supported by five crankshaft bearings that are retained by crankshaft bearing caps which are machined with the block for proper alignment and clearances. The 5.0L and 5.7L engines have two bolts per cap. The number five crankshaft bearing at the rear of the engine is the end thrust bearing. Four connecting rod journals (two rods per journal) are spaced 90 degrees apart.

**Pistons and Connecting Rods** The pistons are cast aluminum that use two compression rings and one oil control ring assembly. The piston is a low-friction, lightweight design with a flat top and barrel-shaped skirt. The piston pins are chromium steel. They have a floating fit in the piston and are retained by a press fit in the connecting rod assembly. The connecting rods are made out of either forged powdered metal or forged steel. They are machined with the rod cap installed for proper clearances and alignment.

**Lubrication** The gear-type oil pump is driven through an extension driveshaft. The extension driveshaft is driven by the distributor which is gear driven by the camshaft. The oil is drawn from the oil pan through a pickup screen and tube. Pressurized oil is delivered through internal passages to lubricate camshaft and crankshaft bearings and to provide valve lash control in the hydraulic valve lifters. Oil is metered from the valve lifters through the valve push rods to lubricate the valve rocker arms and ball pivots. Oil returning to the oil pan from the cylinder heads and the front camshaft bearing, lubricates the camshaft timing chain and crankshaft and camshaft sprockets.

## Tools and Shop Equipment

A clean, well-lit, work area should be available. Other necessary equipment includes: a suitable parts cleaning tank, compressed air supply, trays to keep parts and fasteners organized, and an adequate set of hand tools. An approved engine repair stand will help aid with the work and help prevent personal injury or component damage.

Special tools are listed and illustrated throughout this section with a complete listing at the end of the section. These tools (or their equivalents) are specially designed to quickly and safely accomplish the operations for which they are intended. The use of these special tools will also minimize possible damage to engine components. Some precision measuring tools are required for inspection of certain critical components. Torque wrenches are necessary for the correct assembly of various parts.

## Accessories

The various procedures in this manual assume that the engine accessories have been removed. These accessories include all of the following:

- Power Steering Pump
- Alternator

- Distributor
- Water Supply Pump
- Accessory Brackets and Electrical Wiring
- Starter Motor

## Cleaning

Remove the engine accessories before cleaning to provide better access to the engine's exterior surfaces. After removing the distributor, accessory brackets, etc., cover the openings with tape to prevent the entry of contaminants.

Methods used to clean the engine will depend on the means which are available. Steam cleaning, pressure washing, or solvent cleaning are some of the acceptable methods. Allow the engine to dry thoroughly before beginning any work.

It is important that the engine be as clean as possible to prevent dirt, water, or any other contaminants from entering critical areas during disassembly.

## Draining The Engine

See "Draining Engine Block or Exhaust Manifold" on page 212.

## Engine Lubrication

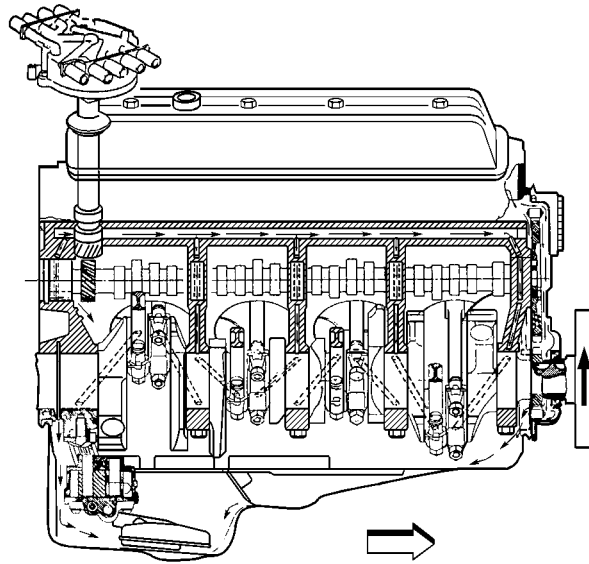

67757

Full pressure lubrication, through a full-flow oil filter is supplied by a gear-type

4. Oil is drawn up through the oil pump screen and passes through the pump to the oil filter. The oil filter is a full-flow paper element unit with an anti-drain back valve. An oil filter bypass valve is used to ensure adequate oil supply, in the event the filter becomes plugged or develops excessive pressure drop.

Filtered oil flows into the main gallery and then to the camshaft, balance shaft, rear bearing, and crankshaft bearings. The valve lifter oil gallery supplies oil to the valve lifters. Oil flows from the valve lifters

through the hollow valve push rods to the valve rocker arms. Oil drains back to the crankcase through oil drain holes in the cylinder head. The camshaft timing chain is drip fed from the front camshaft bearing. The pistons and piston pins are lubricated by oil splash.

## Exhaust Manifold

### Removal

1. Drain water from exhaust manifolds.
2. Disconnect water hose from manifold.
3. Loosen upper exhaust hose clamps, then remove high rise elbow.
4. Remove manifold attaching screws, then remove the manifold.

### Inspection

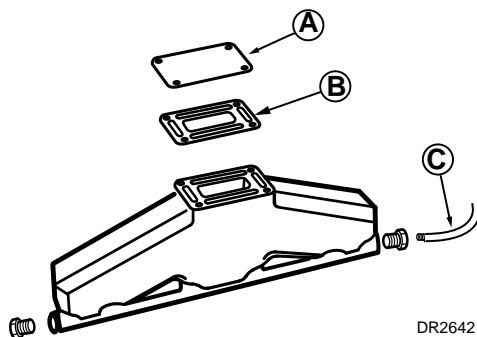

1. Inspect for cracks.
2. To pressure check manifold, use a plate such as pictured, and a new elbow gasket to seal water passage in manifold. Be sure to apply sealer to gasket. Install rubber drain caps to manifold and secure with clamps. Attach a Gearcase Pressure Tester (such as Stevens Company S-34) to the water inlet hose. A bushing can be made to secure pressure tester to hose. With the pressure tester attached to the manifold, submerge manifold in water. Pressurize the manifold to 10-15 PSI (22-25 kPa) and check for leaks. Manifold should not leak around clamps and plate. If so, retighten clamps or reseal plate. No drop in pressure should be realized.

### Installation

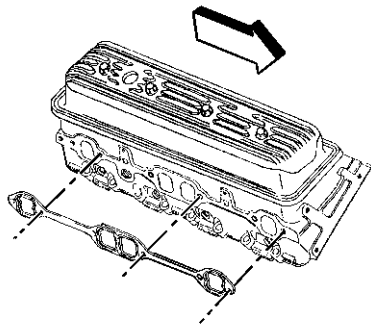

1. Clean mating surfaces on manifold and head. Install new exhaust gasket, then install manifold and secure with screws. Tighten screws to 20-26 ft. lb. (27-35 N•m).

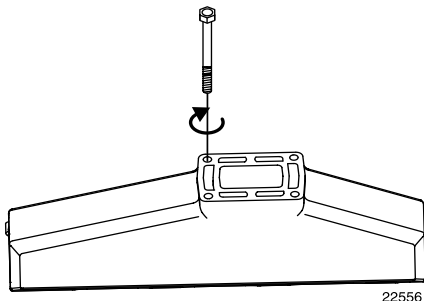

2. Install a new gasket and high rise elbow to manifold. Tighten bolts to 12-18 ft. lb. (16-24 N•m).



### Caution!

**Clean threads in the mounting holes are critical for torquing of the riser bolts and the seal between the riser and manifold.**

Check all riser mounting holes in manifolds for debris or excessive coating on threads.

- Bolts should screw completely in to hole by hand, if not, run tap in holes to clear debris and coating.
- Use shop vacuum to remove debris from holes.



**Caution!**

The gasket mounting surfaces must be clean and flat to insure the correct seal between the riser and manifold. Carefully follow the steps below to insure a good seal.

**Note!** Before proceeding place shop towels in the manifold openings to prevent debris from entering the engine. When the cleaning process is done, use a shop vacuum to remove debris from the manifold, riser and engine.

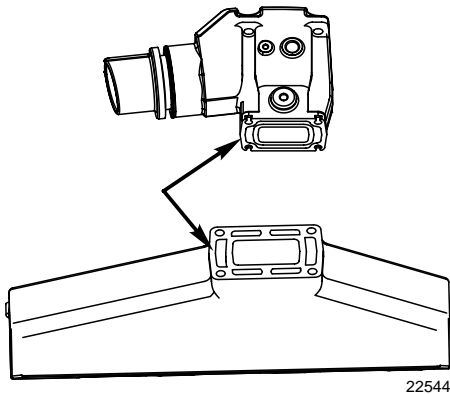

22544

3. Clean the gasket mounting surfaces on both the riser and the manifold.
4. Use spray on gasket remover to remove ALL traces of riser gasket. Heavy scrapping with tools on gasket surfaces may gouge surface, preventing proper seal.
5. Follow pre-cautions on can of gasket remover to prevent damage to paint on manifold, riser or engine.

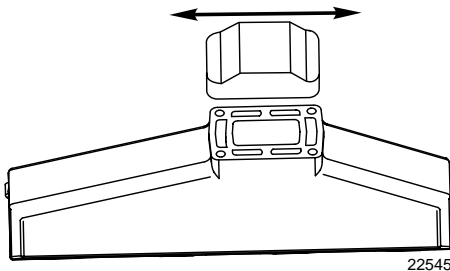

22545

6. Use 80 grit sandpaper and a sanding block, or equivalent to smooth the gasket mounting surfaces on the riser and manifold.

**Note!** do not use rotary power sanding tools, they may leave a circular gouge in the surface.

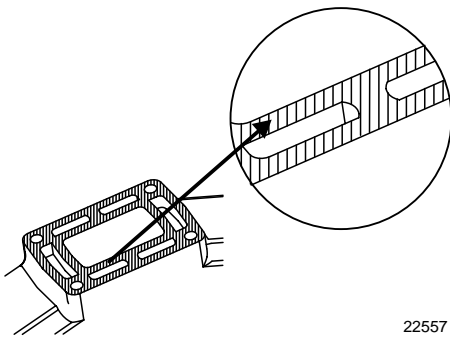

22557

Each area/section of gasket mounting surface (see example in picture) should be flat and smooth to a tolerance of 0.1mm.

If the surface can not be cleaned or sanded to this tolerance, the part must be machined flat at the gasket mounting surface.

If machined, the following applies;

- The maximum material that can be removed is 0.25mm (0.0098 in.)
- Machine flatness over the gasket surface is 0.075mm (0.0029 in.) maximum overall, with not more than 0.02mm (0.000787 in.) allowable over any 25mm (0.98 in.) span.
- Surface finish should not exceed 0.0032mm (0.0001259 in.) Roughness Average

If the surface can not be machined to these specifications the part must be replaced.

7. Place gasket over mounting surface on manifold.

**Note!** Be careful not to scratch or cut the black coating on the riser gasket.

**Note!** Do not use any sealant on the riser gasket.

8. Install riser, on to exhaust manifold.
9. Make sure gasket is properly placed.
10. Install bolts and washers to secure riser.
11. Install any parts secured under bolts.
12. Torque riser bolts in a crossing pattern to 40 Nm (30 ft. lb.). Make at least two passes to insure proper torque is reached.
14. Install all other parts mounted to risers.
15. Install exhaust hose and secure with clamps.
16. Connect water hose and secure with clamp.
17. Start engine and check for fuel leaks.

## Starter

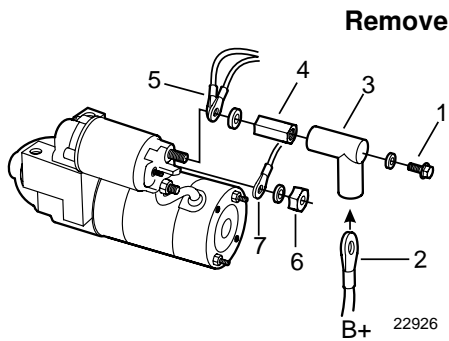

1. Disconnect power from the engine.
2. Remove battery cable (2) from solenoid extension nut
3. Remove solenoid extension nut (4) and cover (3) from solenoid.
4. Remove accessory wires from solenoid (5).
5. Remove start wire nut (6).
6. Remove start wire from solenoid start terminal (7).

**Note!** GL engines have an additional purple wire attached to the solenoid “R” terminal.

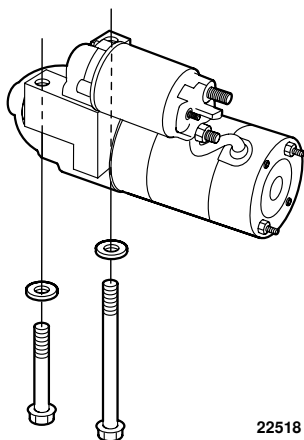

7. Remove starter mounting bolts.
8. Remove starter.

### Installation

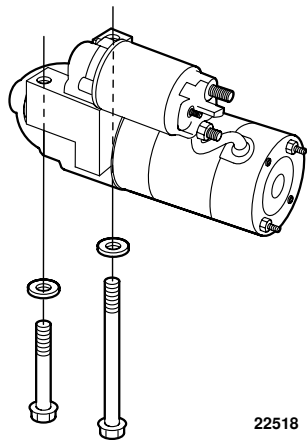

22518

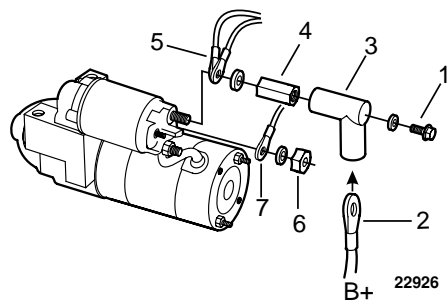

22926

1. Hold stater against engine mounting pad with mounting holes aligned.
2. Install starter bolts and tighten to 41-49 Nm (30-36 ft.lb).

3. Connect accessory wires (5) to solenoid.
4. Install solenoid extension nut (4) and washer on solenoid terminal. Tighten to 19 - 28 N•m (14 - 20 ft. lb.)
5. Install solenoid extension nut cover (3).
6. Connect battery cable (2) to solenoid extension nut.
7. Install battery cable bolt (1) and washer. Tighten to 19 - 28 N•m (14 - 20 ft. lb.)



#### Caution!

**DO NOT overtighten the battery cable bolt. The starter solenoid will be damaged.**

8. Install start wire (7) on solenoid stud "S".
9. Install start wire nut (6) and washer. Tighten to 3 - 5 N•m (26 - 44 in. lb.)
10. Connect start wire to solenoid start terminal (1).
11. On GL models, connect the purple wire to the solenoid "R" terminal in the same manner.

## Intake Manifold

### Removal

1. Disconnect power from engine.
2. Remove drain plug from and starboard side of engine block.

**Note!** If water does not drain, use a small piece of wire to open the drain hole.

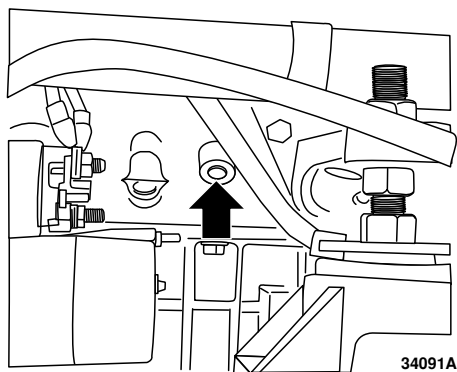

34091A



3. Remove drain plug from and port side of engine block.

**Note!** If water does not drain, use a small piece of wire to open the drain hole.

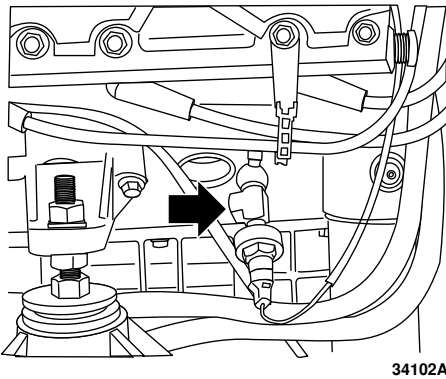

4. Drain coolant from Exhaust Manifolds.

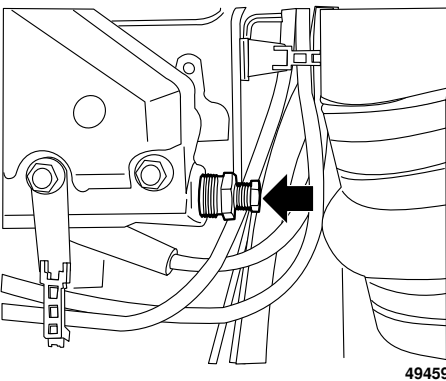

**Disconnect:**

5. Disconnect hoses from thermostat housing.

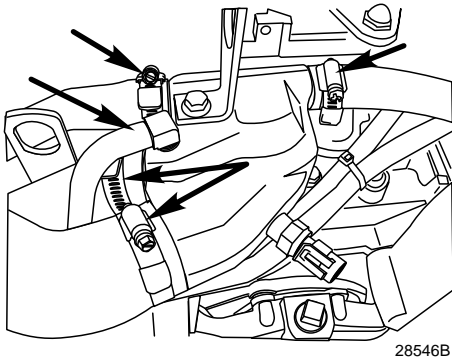

6. Disconnect Throttle cable.

- a. Remove cotter pin (1) and washer (2) and remove throttle cable from throttle lever.
- b. Loosen and remove anchor block bolt (3) and nut (4).
- c. Release cable block (5) and trunnion (6).

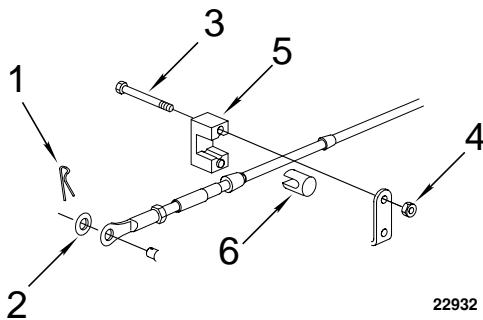

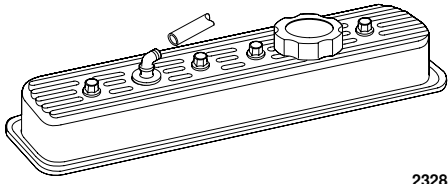

23288

**Remove:**

7. Crankcase ventilation hose from rocker arm covers (both sides if applicable).

1. Disconnect wire at temperature gauge sender unit and engine wiring harness from alternator.

**Remove Distributor, Gi and GXi Models**

GL Models: See *Electric, Fuel and Ignition Workshop Manual* 7743454.

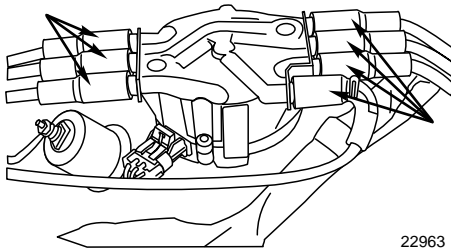

22963

1. Disconnect distributor high tension leads and ignition primary lead from distributor cap.

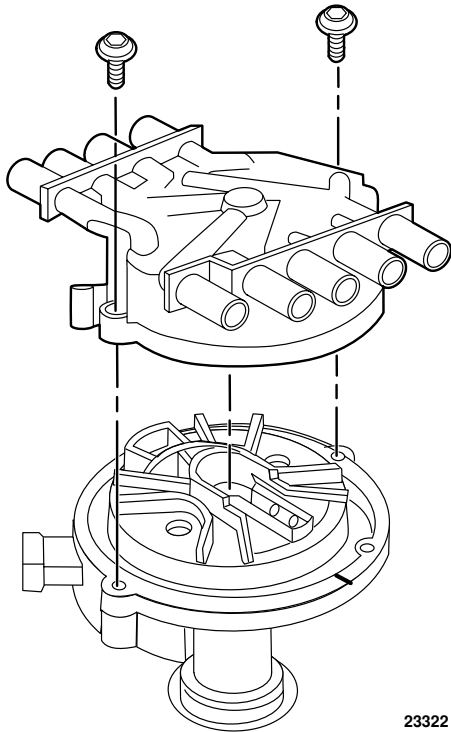

23322

2. Remove the distributor cap bolts and discard.
3. Remove the distributor cap.

4. Mark the position of the rotor on the housing.

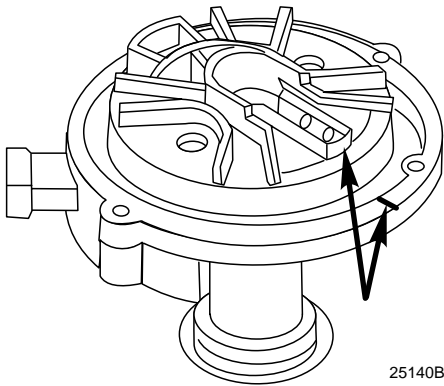

5. Scribe a line on distributor housing and intake manifold for reassembly in the same position.

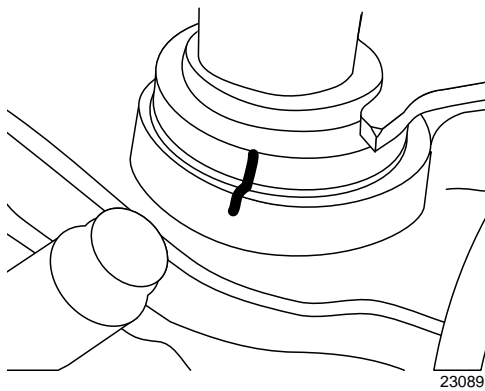

6. Loosen hold down clamp and remove the distributor.

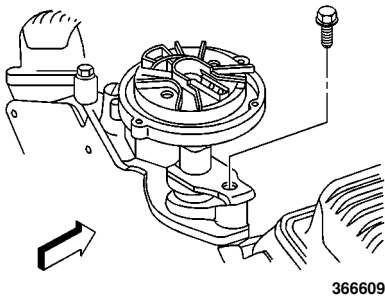

7. Remove Distributor and discard Gasket.
8. Disconnect and remove alternator.
9. Remove Fuse box (GX-i-B and later only).
10. Carburetor fuel line from carburetor and fuel pump or fuel lines from fuel rails. To disconnect fuel lines from fuel rail, see *Quick Connect Fitting Service* on page 346 of *EFI Diagnostic Workshop Manual 7742218*.

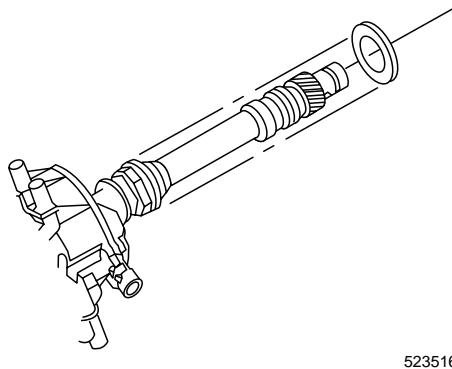

**⚠ Caution! Refer to Fuel Pressure Relief Procedures found on page 345 of *EFI Diagnostic Workshop Manual 7742218* before servicing any part of the fuel system.**

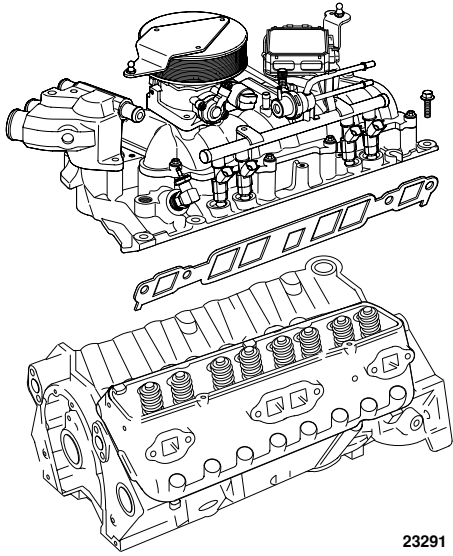

11. Remove intake manifold attaching bolts. Lift manifold from engine. Discard front and rear seals and gaskets.

**Note!** If manifold is to be replaced, transfer: carburetor or throttle body, fuel rail assemblies, thermostat and housing (use new gasket), throttle cable anchor block assembly, distributor clamp and temperature sending unit. Transfer additional hardware as required.

**Clean:**

- Old pieces of gasket or RTV from the gasket surfaces.
- Excessive carbon build-up in the intake passages of the intake manifold.
- Scale and deposits from the coolant passages of the intake manifold.

**Disassemble Intake Manifold (GXl-B and later only)**

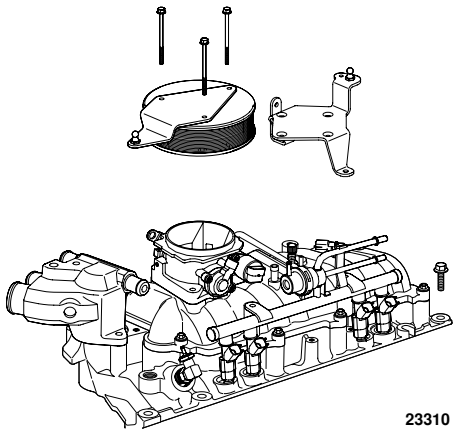

12. Remove Flame arrester and bracket.
13. Remove fuse box (GXl-B and later only).

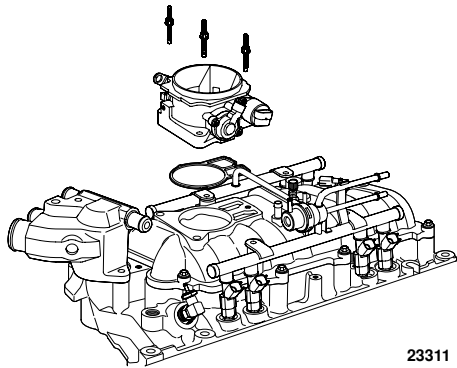

14. Remove throttle body attaching studs.
15. Remove throttle body and gasket. Discard the gasket.

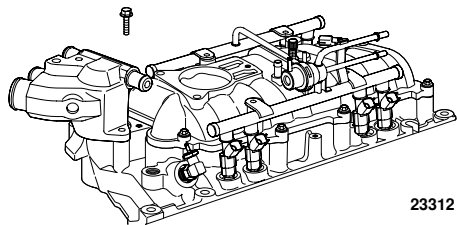

16. Remove Thermostat housing bolts.

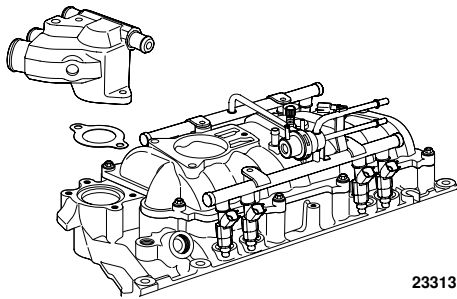

17. Remove Thermostat housing and discard gasket.

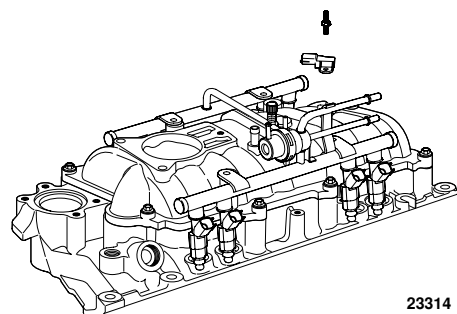

18. Remove MAT/MAP sensor stud and remove sensor from manifold.

19. Remove four retaining studs and remove fuel rail assembly.

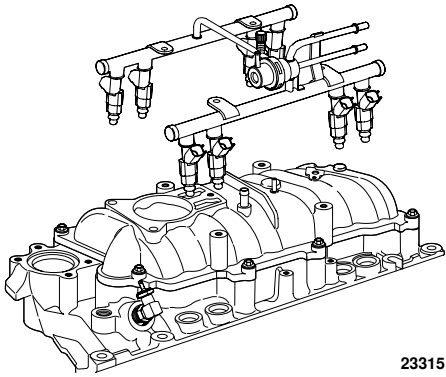

23315

20. Remove upper intake manifold attaching bolts.

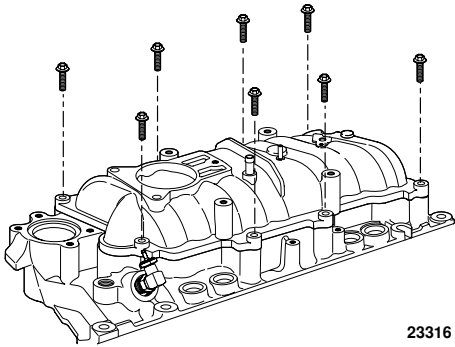

23316

21. Remove upper intake manifold.  
22. Remove and discard upper intake manifold to lower intake manifold gasket.

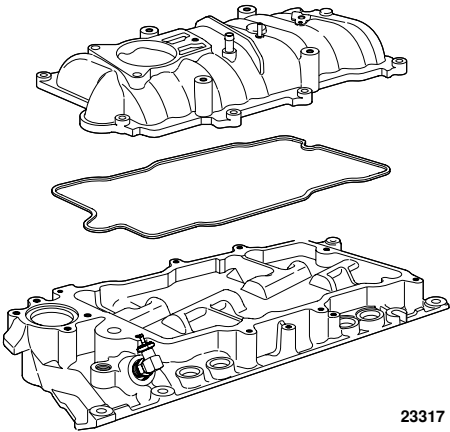

23317

23. Remove impulse limiter.

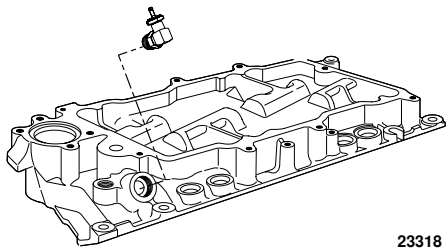

23318

**Clean and Inspect**

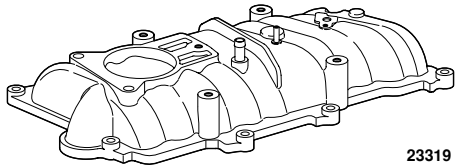

23319



**Wear Safety Glasses**

1. Clean the upper intake manifold in cleaning solvent.
2. Dry the upper intake manifold with compressed air.

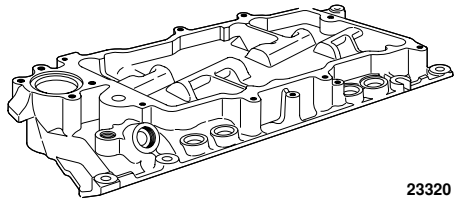

23320

**Assemble Intake Manifold**

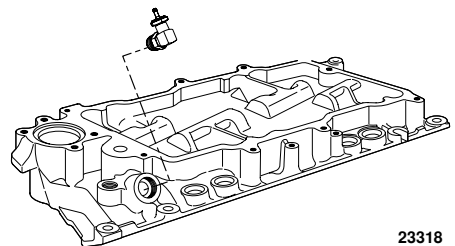

23318

1. If removed, coat the threads of the impulse limiter with sealing compound P/N 1141570.
2. Install impulse limiter into lower intake manifold and tighten to 14-19 N•m (10-14 ft. lb.).

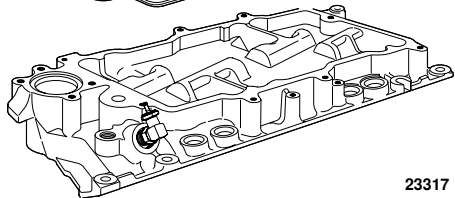
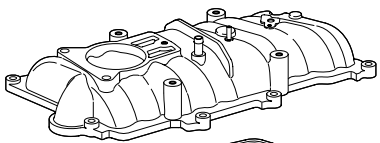

23317

3. Place a NEW upper intake manifold gasket into the upper intake manifold gasket groove.
4. Place the upper intake onto the lower intake manifold.

**Note!** If reusing the fasteners, apply threadlock Volvo Penta P/N 1161053 or equivalent to the threads of the fuel meter body bracket bolt.

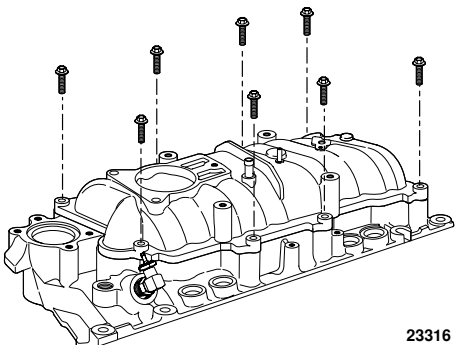

23316

5. Install upper intake manifold bolts.
6. Tighten the upper intake manifold bolts in two stages.
  - First pass 5 N•m (44 in. lb.).
  - Final pass 9 N•m (80 in. lb.).

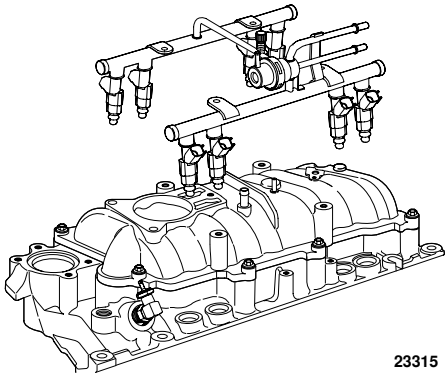

**Intake Manifold Installation**

**Install or Connect:**

7. Inspect O-rings on fuel injectors. Replace any damaged, cut, or missing O-rings.
8. Install the fuel injectors into the lower intake manifold.
9. Install the fuel rail retaining studs and tighten to



**Caution!**

**Do NOT reuse intake manifold gaskets.**

Sealant to the intake manifold gasket, cylinder head side.

**Note! Care must be used to apply the correct amount of sealant onto the gaskets. Applying excessive amounts of sealant may prohibit the intake gaskets from sealing properly.**

1. Apply a 4.0 mm (0.157 in) patch of adhesive Volvo Penta P/N 1161277 or equivalent to the cylinder head side of the lower intake manifold gasket at each end.

**Note! The lower intake manifold gasket must be installed while the adhesive is still wet to the touch.**

2. Install the lower intake manifold gasket onto the cylinder head. Use the gasket locator pins in order to properly seat the lower intake manifold gasket on the cylinder head.

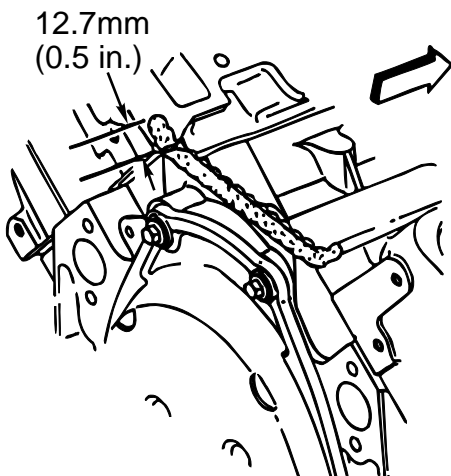
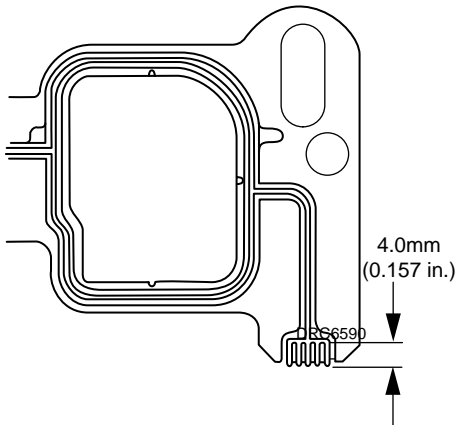

**Notice: Care must be used to apply the correct amount of sealant onto the gaskets. Applying excessive amounts of sealant may prohibit the intake manifold gaskets from sealing properly.**

**Important: The lower intake manifold must be installed and the fasteners tightened while the adhesive is still wet to the touch.**

3. Apply a 5.0 mm (0.197 in) bead of adhesive Volvo Penta P/N 1161277 or equivalent to the front top of the engine block.



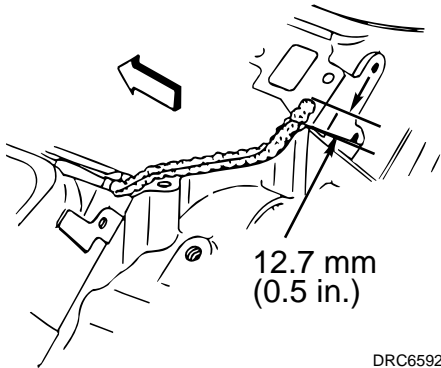

DRC6592

4. Apply a 5.0 mm (0.197 in) bead of adhesive Volvo Penta P/N 1161277 or equivalent to the rear top of the engine block. Extend the adhesive bead 13 mm (0.50 in) onto each lower intake manifold gasket.

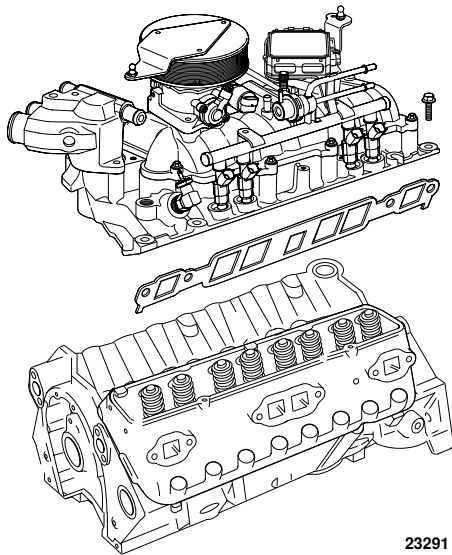

23291

5. Install the intake manifold assembly onto the engine block.
6. If reusing the fasteners, apply threadlock Volvo Penta P/N 1161053 or equivalent to the threads of the manifold bolts.
7. Install the manifold bolts.

Tighten:



**Caution!**

**Proper lower intake manifold fastener tightening sequence and torque is critical. Always follow the tightening sequence, and torque the intake manifold bolts using the 3 step method. Failing to do so may distort the crankshaft bearing bore alignment and cause damage to the crankshaft bearings.**

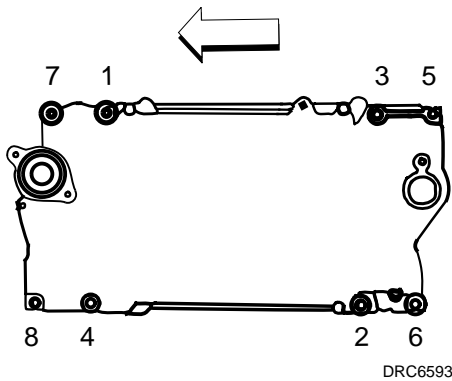

DRC6593

8. Tighten the intake manifold bolts.
  - a. Tighten the bolts in sequence (1-8) on the first pass to 3 N•m (27 lb. in).
  - b. Tighten the bolts in sequence (1-8) on the first pass to 12 N•m (106 lb. in).
  - c. Tighten the bolts in sequence (1-8) on the first pass to 15 N•m (11 lb. ft.).
9. Connect fuel lines to fuel rail. See Quick Connect Fitting Service on page 346 of *EFI Diagnostic Workshop Manual 7742218*.

**Distributor Installation**

Install distributor with rotor and aligned exactly as marked during removal.

**NOTE!** If the crankshaft was moved while distributor was out, complete ignition timing procedure must be followed. See below.

**Gi and GXi models**

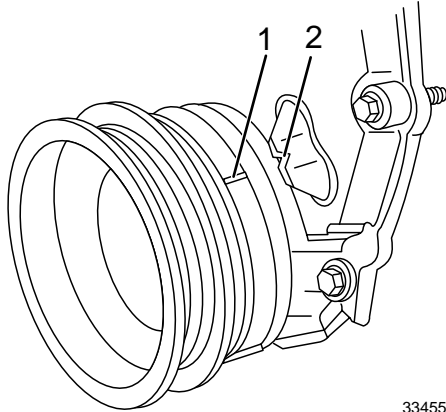

334551

GL models: See *Electric, Fuel and Ignition Workshop Manual* 7743454.

1. Rotate the crankshaft balancer clockwise until the alignment marks on the crankshaft balancer (1) are aligned with the tabs on the engine front cover (2) and the number 1 piston is at top dead center of the compression stroke.

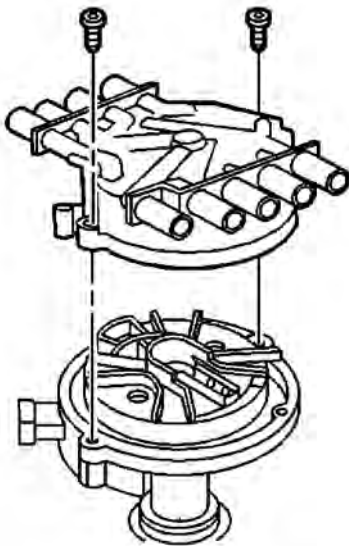

500690

2. If not already removed, remove and discard the distributor cap screws.
3. Remove the distributor cap

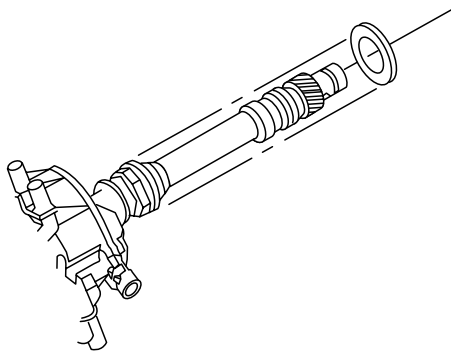

523516

4. Install NEW distributor gasket onto the distributor.

5. Align the indent hole on the distributor gear with the paint mark on the distributor housing.

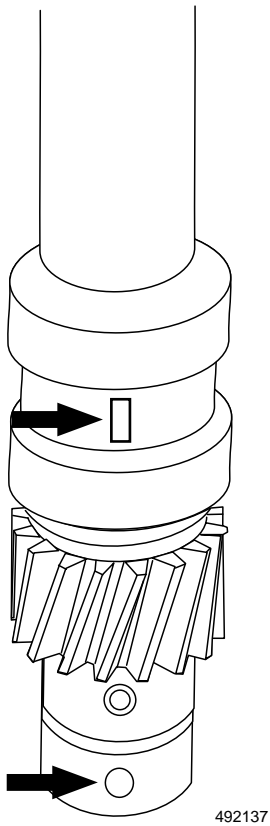

6. Align the slotted tang in the oil pump driveshaft with the distributor driveshaft. Rotate the oil pump driveshaft with a screwdriver if necessary.

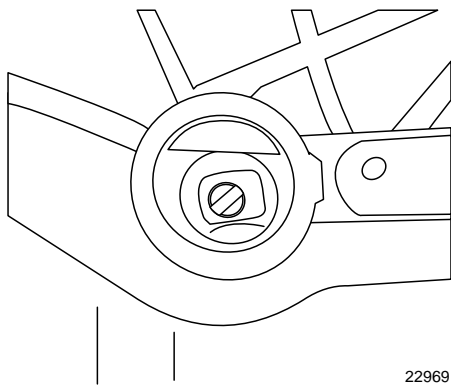

7. Align the flat (1) in the distributor housing toward the front of the engine.

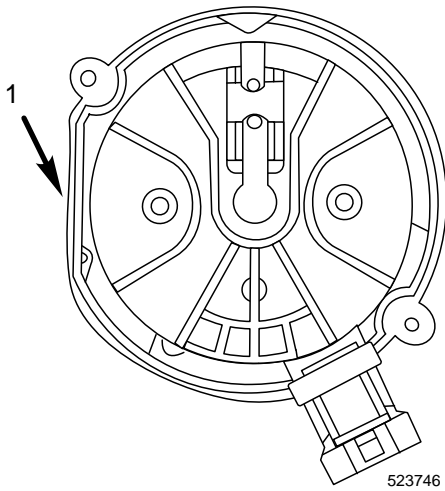

8. Install the distributor and distributor clamp. The flat in the distributor housing must be pointing toward the front of the engine.

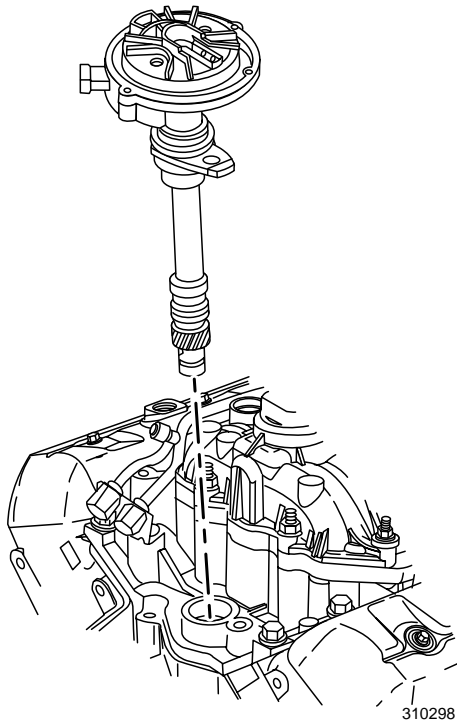

9. Once the distributor is fully seated, align the distributor rotor segment with the number 8 pointer (1) that is cast into the distributor base.

**Note!** If the distributor rotor segment does not come within a few degrees of the number 8 pointer, the gear mesh between the distributor and camshaft may be off a tooth or more. Repeat the procedure again in order to achieve proper alignment.

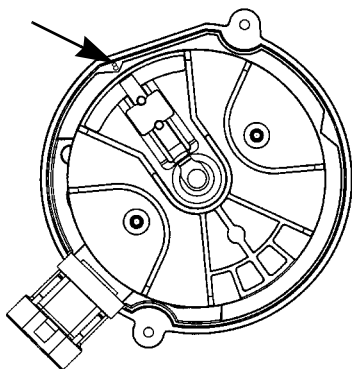

68505

10. Install the distributor clamp bolt, and Tighten the bolt to 25 N.m (18 lb. ft.).

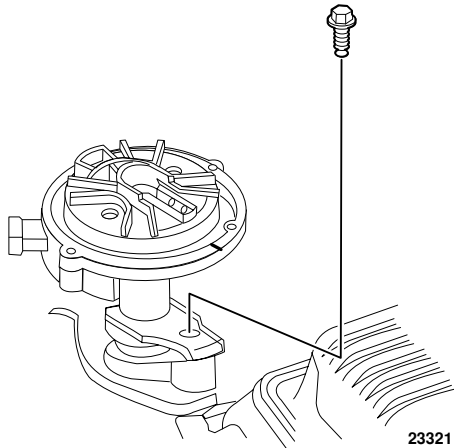

11. Install the distributor cap and NEW distributor cap bolts. Tighten the screws to 2.4 N.m (21 lb. in).
12. Set timing, GL Models see *Electrical Fuel and Ignition Workshop Manual 7743454*. Gi and GXi Models see *EFI Diagnostic Workshop Manual 7742218 On Board Repair*.

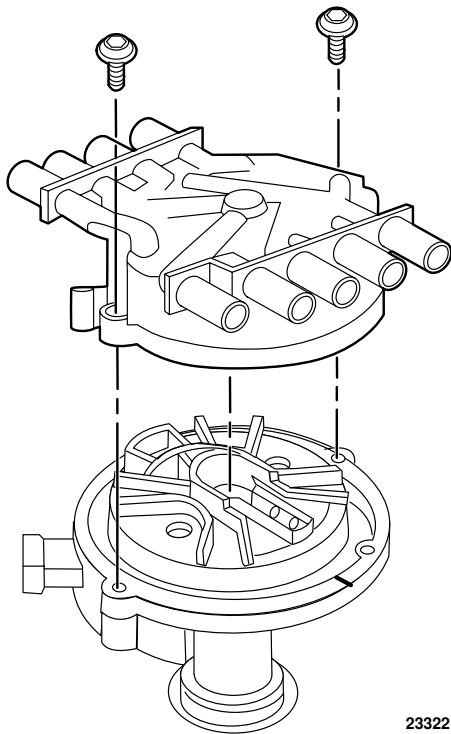

**Alternator with mounting bracket.**

13. Install distributor cap and high tension leads. See the General Information section in Electrical/Ignition/Fuel Service Manual for correct firing order and spark plug wire routing.
14. Install oil pressure sending unit.

**Connect:**

15. All electrical connections. Apply black neoprene dip, or equivalent, on all exposed connections.
16. Fuel lines to carburetor and fuel pump or throttle body and fuel pump/vapor separator.
17. Throttle cable.
18. All water hoses, and close all drain petcocks.
19. Both crankcase ventilation hoses.
20. Battery cables.

21. Start engine. Check ignition timing, carburetor idle speed and mixture. Check for leaks.

## Rocker Arm Cover

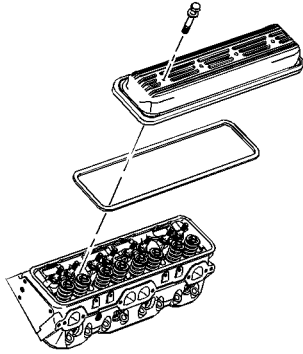

- Remove:**
1. Valve rocker arm cover bolts.
  2. Valve rocker arm cover.
  3. Gasket.

39119

- Clean:**
- a. Parts in solvent. Remove all sludge and varnish.
  - b. Old gaskets from the gasket surfaces.

- Inspect:**
- a. Gasket flanges for bending or damage.
  - b. Rubber grommets and parts for deterioration.

- Installation**
1. New gasket.
  2. Valve rocker arm cover.
  3. Valve rocker arm cover bolts.

- Tighten:**
1. Valve rocker arm cover bolts to 106 in. lb. (12 N•m).

## Valve Train

**Removal**



**Caution!**

**Store all reusable components in an exact order, so they can be reassembled in the same wear pattern location from which they were removed. Mark the front end of the retainer.**

1. Remove rocker arms.

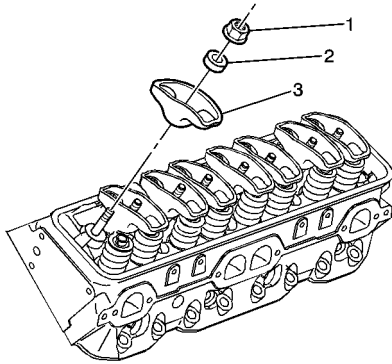

182835

2. Remove pushrods and keep in order with the valve lifters and rocker arms.

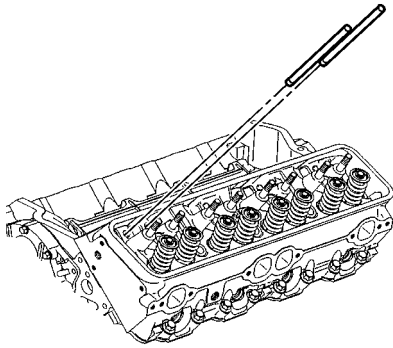

22766

3. Remove valve lifter retainer bolts and valve guide retainer.

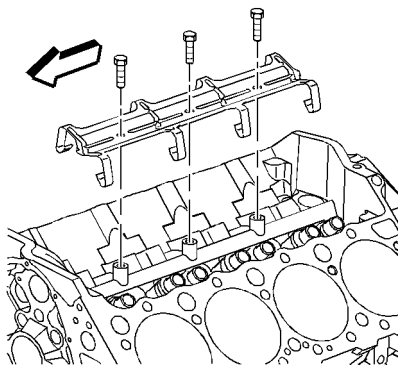

11508

4. Remove the valve guides and valve lifters.

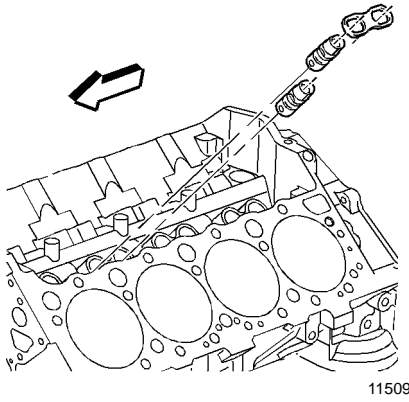

11509

5. Remove the lifters one at a time using J 9290-01/J 3049 or equivalent and place them in an organizer rack.
6. Store all reusable components in an exact order, so they may be reassembled in the same wear pattern location from which they were removed.

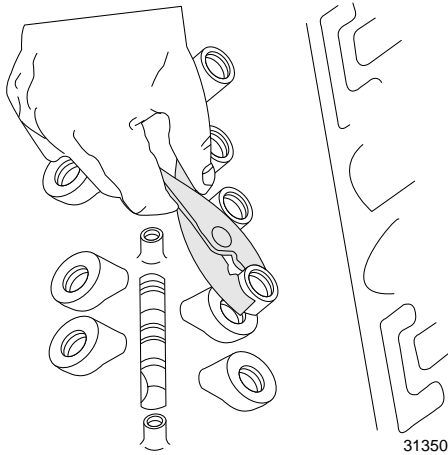

31350

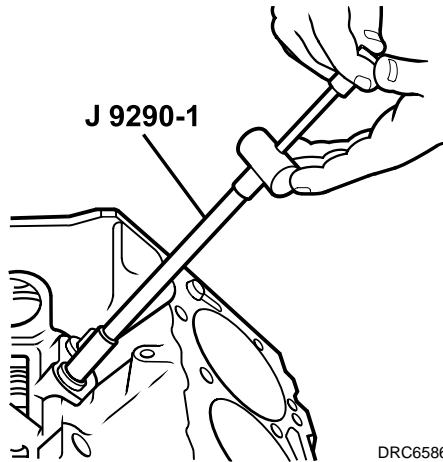

DRC6586

- Clean:**
1. Mark, sort and organize the components for assembly.
  2. Clean the components with cleaning solvent.
  3. Dry the components with compressed air.



**Inspect:** **NOTE! Parts that are to be reused must be marked, sorted and organized for assembly.**

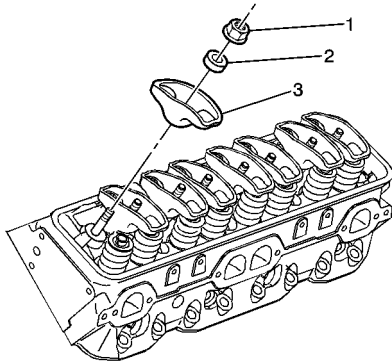

182835

4. Inspect the valve rocker arm components for the following:
  - Wear or scoring of the valve rocker arm (3) ball area.
  - Valve rocker arm (3) pushrod sockets and valve stem contact surface. The contact surfaces should be smooth with no scoring or excessive wear.
  - Valve rocker arm ball (2) for wear or scoring. The contact surfaces should be smooth with no scoring or excessive wear

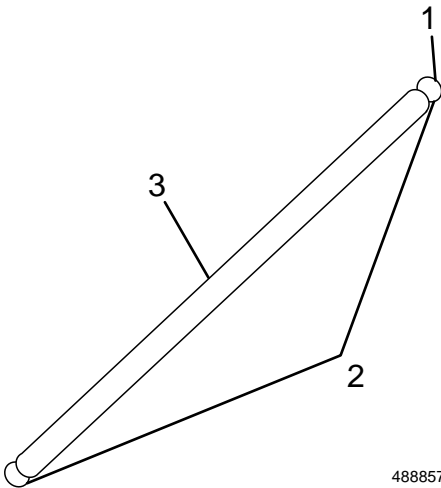

488857

5. Inspect the valve push rods for the following:
  - Restriction of the oil passage (1)
  - Wear or scoring of the end contact surfaces (2). The end contact surfaces must be smooth with no scoring or excessive wear.
  - Shaft for bends (3). Roll the valve pushrod on a flat surface to determine if the valve pushrod is bent.

**Valve Lifters and Guides Clean and Inspect**

**NOTE! Parts that are to be reused must be marked, sorted and organized for assembly.**

1. Mark, sort and organize the components for assembly.
2. Clean the components with cleaning solvent.



**Warning!**

**Always wear safety glasses when using compressed air.**

3. Dry the components with compressed air.

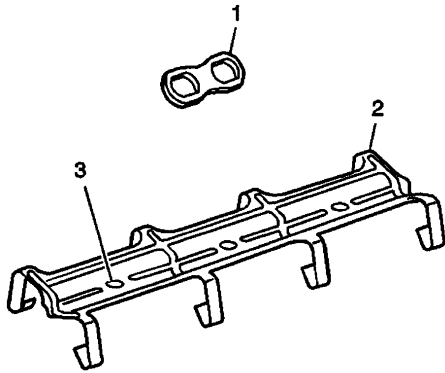

521834

4. Inspect the valve lifter pushrod guides (1) for excessive wear, cracks or damage.
5. Inspect the valve lifter guide retainer for wear, damage or stress cracking in the leg areas (2) and wear or damage in the bolt holes (3).

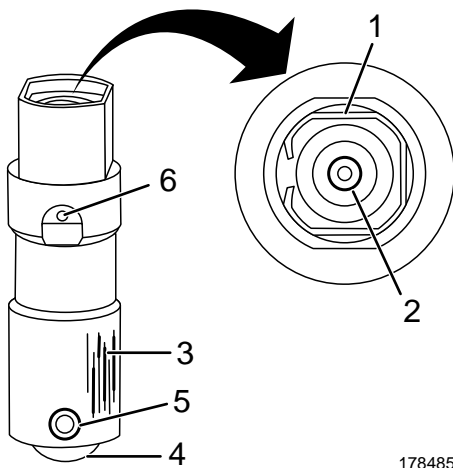

178485

6. Inspect the valve lifter for the following:

- Broken or damaged clip (1)
- Worn pushrod socket (2)
- Scuffed or worn lifter body (3)

If the valve lifter shows scuffing or wear, inspect the engine block valve lifter bores for wear.

- Worn roller (4)
- Loose or damaged pin (5)
- Plugged oil hole (6)

### Installation

If replacing valve lifters, change the engine oil and filter, and add GM Engine Oil Supplement, P/N 1052367, or equivalent to the engine oil whenever a new camshaft is installed.

**NOTE! Lubricate the valve lifter bodies and roller with GM Engine Oil Supplement, P/N 1052367, or equivalent.**

### Valve Lifter Installation

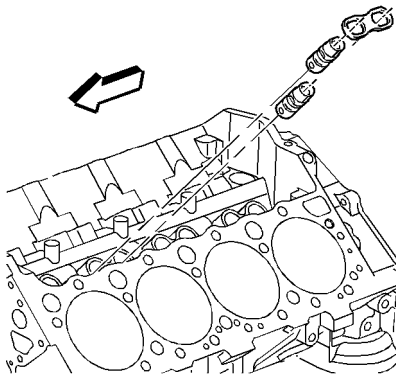

11509

1. Apply lubricant GM P/N 12345501 or equivalent to the valve lifter rollers.

**NOTE! If reusing the valve lifters, install the valve lifters in the original positions.**

2. Install the valve lifters.

### Valve Lifter Pushrod Guides

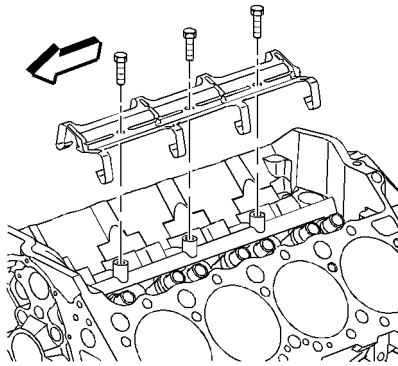

11508

3. Install the valve lifter pushrod guides.
4. Tighten the valve lifter pushrod guide bolts to 25 N•m (18 lb. ft.).

### Valve Push Rod

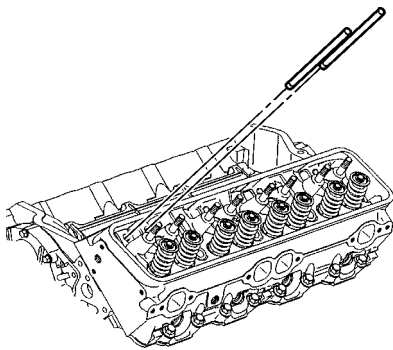

22766

Important: Be sure to keep parts in order. Parts must be reinstalled into the original location and position.

1. Install the valve pushrods.
  - Seat the valve push rods into the socket of the valve lifters.

### Install Rocker Arm Assemblies

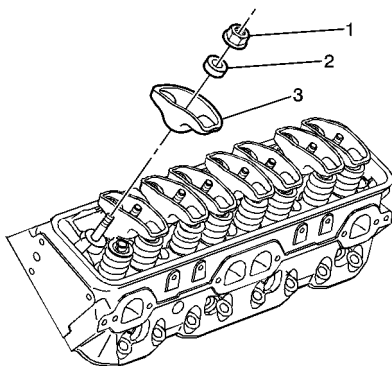

182835

2. Install the following components:
  - Install the valve rocker arms (3)
  - Install the rocker arm balls (2)
  - Install the valve rocker arm nuts (1)

## Valve Lash Adjustment

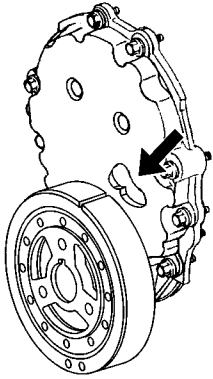

195336

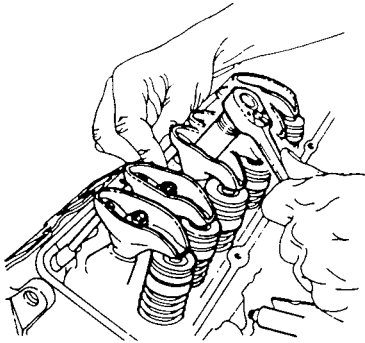

22759

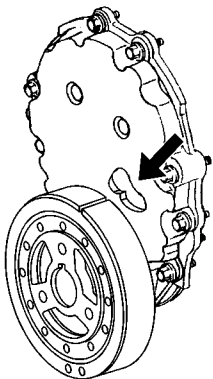

195336

1. Turn the valve rocker arm nuts clockwise until all of the valve lash is removed.
2. Turn the crankshaft clockwise until the alignment mark on the crankshaft balancer is aligned with the notch in the engine front cover tab.
3. Look at the number 1 cylinder valves as the crankshaft balancer alignment mark approaches the notch in the engine front cover tab. If a valve moves as the alignment mark moves into position, the engine is in the number 6 firing position. If this happens, turn the crankshaft clockwise one revolution in order to reach the number 1 firing position.
4. With the engine in the number 1 cylinder firing position, adjust the exhaust valves for cylinder numbers 1, 3, 4, and 8 and the intake valves for cylinder numbers 1, 2, 5, and 7 using the following process:
  - Turn the valve rocker arm nut counterclockwise until the valve lash is felt in the valve pushrod.
  - Turn the valve rocker arm nut clockwise until all the valve lash is removed (zero valve lash). Zero valve lash can be felt by moving the pushrod up and down between you thumb and forefinger until there is no more up and down movement of the pushrod.
  - When all the valve lash is removed, then turn the valve rocker arm nut clockwise 1 additional turn (360°)
5. Turn the crankshaft clockwise 1 revolution until the alignment mark on the crankshaft balancer is aligned with the notch in the engine front cover tab.

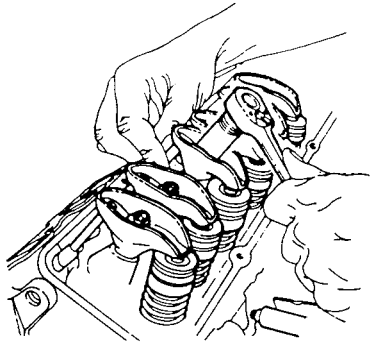

22759

6. With the engine in the number 6 cylinder firing position, adjust the exhaust valves for cylinder numbers 2, 5, 6 and 7 and the intake valve for cylinder numbers 3, 4, 6 and 8 using the following process:

- Turn the valve rocker arm nut counterclockwise until the valve lash is felt in the valve pushrod.
- Turn the valve rocker arm nut clockwise until all the valve lash is removed (zero valve lash). Zero valve lash can be felt by moving the pushrod up and down between you thumb and fore-finger until there is no more up and down movement of the pushrod.
- When all the valve lash is removed, then turn the valve rocker arm nut clockwise 1 additional turn (360°)

### Valve Rocker Arm Cover Installation

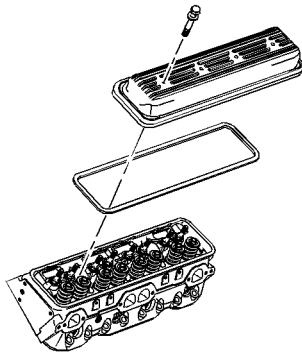

39119

1. Install the NEW valve rocker arm cover gasket into the groove of the valve rocker arm cover.



#### Caution!

**Do not reuse the valve rocker arm cover gasket or the valve rocker arm cover grommets.**

2. Install the NEW valve rocker arm cover bolt grommets into the valve rocker arm cover.
3. Install the valve rocker arm cover onto the cylinder head.
4. Install the valve rocker arm cover bolts.
5. Tighten the valve rocker arm cover bolts to 12 N.m (106 lb. in).

## Cylinder Head

### Removal

Intake manifold See "Intake Manifold" on page 58.

Remove rocker arm covers See "Rocker Arm Cover" on page 72.

1. Remove spark plugs.

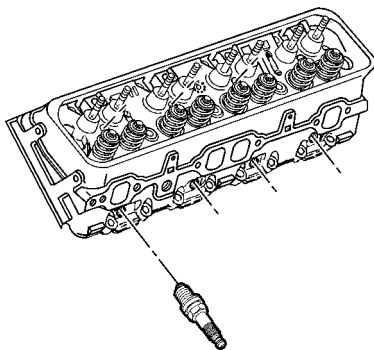

317307

2. Remove cylinder head bolts.

**Note!** Place cylinder head on two wooden blocks to prevent damage.

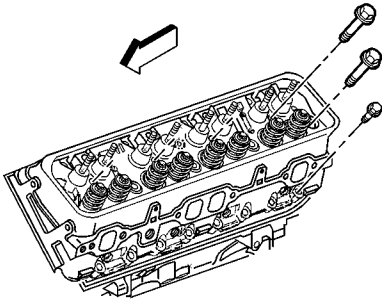

317217

3. Remove cylinder heads.

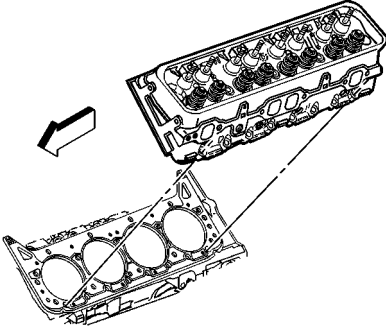

317227

4. Remove and discard head gaskets.

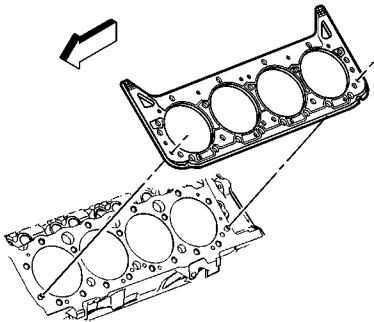

317233

- If required, remove the dowel pin (cylinder head locator).

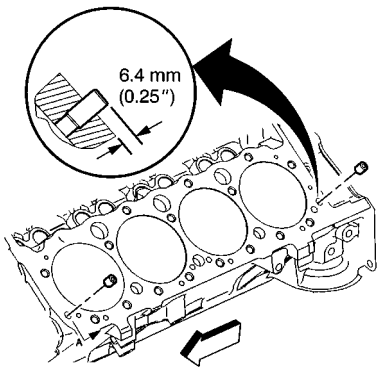

182846

### Cylinder Head Disassemble and Recondition

Tool Required: J 8062 Valve Spring Compressor

#### Disassemble:

- Compress the springs with J 8062.

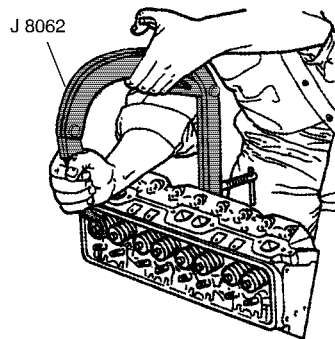

34468



#### Warning!

**Wear safety glasses. Compressed valve springs have high tension against the valve spring compressor. Valve springs that are not properly compressed by or released from the valve spring compressor can be ejected from the valve spring compressor with intense force. Use care when compressing or releasing the valve spring with the valve spring compressor and when removing or installing the valve stem keys. Failing to use care may cause personal injury.**

Important: Mark, sort and organize the components so that the components can be reinstalled in their original location and position.

- Remove the valve stem keys (1).
- Remove the J 8062 from the cylinder head.
- Remove the valve spring cap (2).
- Remove the valve spring (3).
- Remove the valve stem oil seal (4).
- Discard the valve stem oil seal.
- Remove the valve.

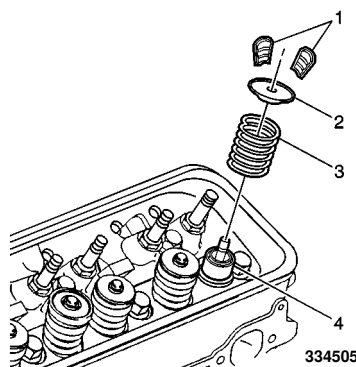

334505

## Cylinder Head Clean and Inspect

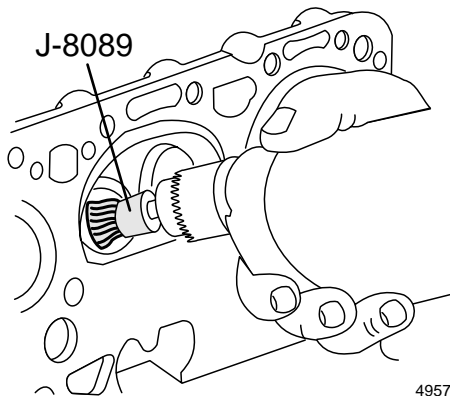

### Clean:

#### Tools Required

- J 8001 Dial Indicator Set
- J 8089 Carbon Removing Brush
- J 9666 Valve Spring Tester



### Caution!

#### Wear Safety Glasses.

1. Clean the valve stems and cylinder heads on a buffing wheel.
2. Clean the following components in cleaning solvent:
  - Valve stem keys (1)
  - Valve spring cap (2)
  - Valve spring (3)
  - Cylinder head
3. Dry the components with compressed air.
4. Use the J 8089 to clean the carbon from the cylinder head combustion chambers.



### Caution!

#### Be careful not to scuff the combustion chambers.

5. Inspect the cylinder head for the following:
  - Damage to the gasket surfaces
  - Damage to the threaded bolt holes
  - Burnt or eroded areas in the combustion chambers
  - Cracks in the exhaust ports and combustion chambers
  - External cracks in the water chambers
  - Restrictions in the intake or exhaust passages
  - Restrictions in the cooling system passages
  - Rusted, damaged or leaking core plugs
6. Measure the cylinder head for warping with a straight edge and feeler gauge
  - A cylinder head block deck with warping in excess of 0.10 mm (0.004 in) within a 152.4 mm (6.0 in) area must be repaired or replaced.
  - A cylinder head exhaust manifold deck with warping in excess of 0.05 mm (0.002 in) within a 152.4 mm (6.0 in) area must be repaired or replaced.
  - A cylinder head intake manifold deck with warping in excess of 0.10 mm (0.004 in) within a 152.4 mm (6.0 in) area must be repaired or replaced.

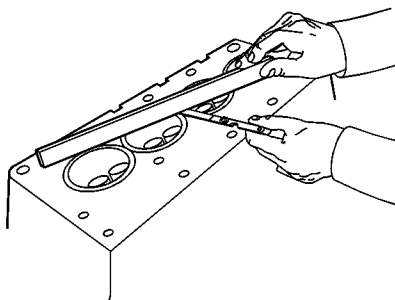

### Inspect:



**Valve Spring Tension**

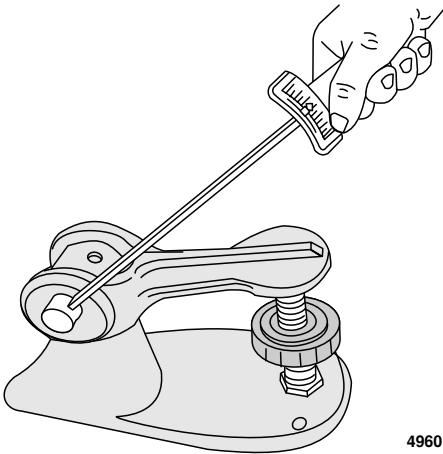

4960

7. Use the J 9666 in order to measure the valve spring.

Replace the valve spring if the valve spring tension is less than 338 N (76 lb.) at 43.2 mm (1.70 in).

**Valve Spring Straightness**

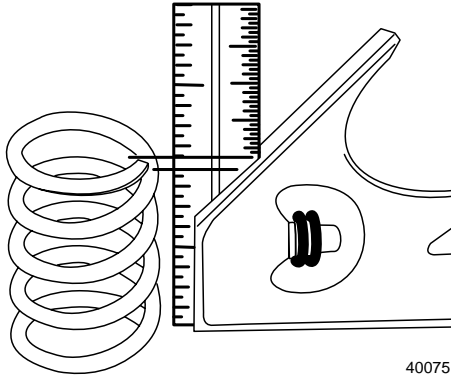

40075

8. Inspect the valve springs for Straightness.

**Valve Stems**

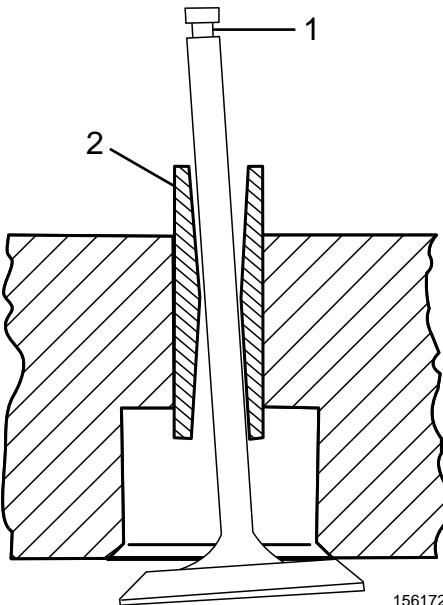

156172

9. Valve stems (1) with excessive valve guide (2) clearance must be repaired or the cylinder head replaced.

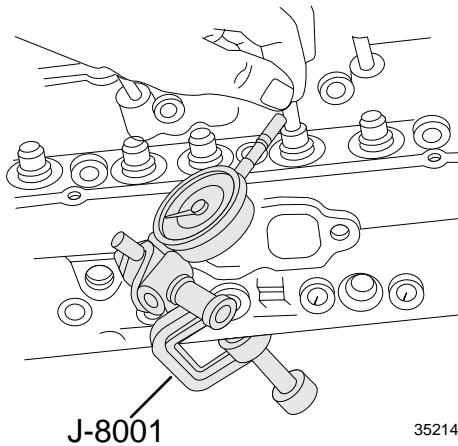

10. Measure the valve stem-to-guide clearance.

Excessive valve stem-to-guide clearance may cause an excessive oil consumption and may also cause a valve to break. Insufficient clearance will result in noisy and sticky functioning of the valve and will disturb the engine assembly smoothness.

- a. Clamp the J 8001 on the exhaust port side of the cylinder head.
- b. Position the dial indicator so that the movement of the valve stem from side to side (crosswise to the cylinder head) will cause a direct movement of the dial indicator stem. The dial indicator stem must contract the side of the valve stem just above the valve guide.
- c. Drop the valve head about 1.6 mm (0.063 in) off the valve seat.
- d. Use light pressure and move the valve stem from side to side in order to obtain a valve stem-to-guide clearance reading.

**Valve Guide Reaming and Seat Grinding**

**Measuring:**

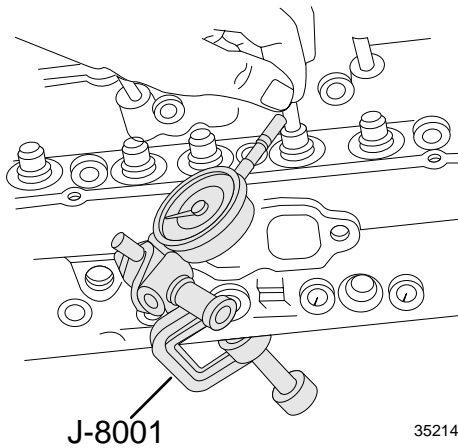

**Tools Required:**

J 5830-02 Valve Guide Reamer Set

J 8001 Dial Indicator Set

1. Measure the valve stem-to-guide clearance. Cylinder Head Clean and Inspect” on page 82.

2. Improper valve stem (1) to valve guide (2) clearance may cause excessive oil consumption.

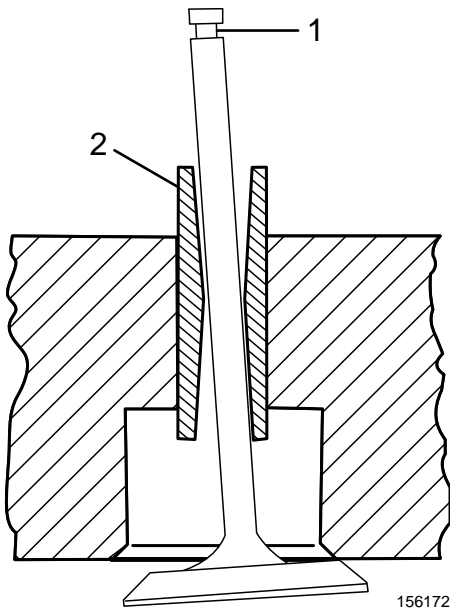

Reaming:

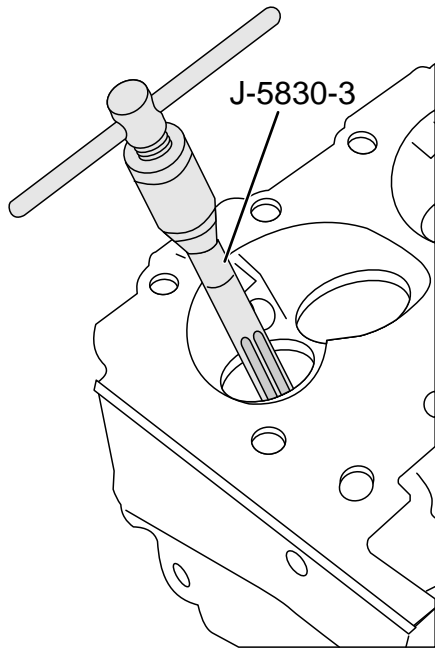

480556



**Warning!**

**Wear Safety Glasses.**

**Note!** Exhaust valves with excessive valve stem-to-guide clearance must be replaced with the available service valve that has an 0.0774 mm (0.0305 in) oversize valve stem. The intake valves are NOT available with oversize valve stems. Replace the cylinder head if after using a NEW intake valve in order to measure the valve stem-to-guide clearance, the valve stem-to-guide clearance is not within specifications.

3. Use the J 5830-3 in order to ream the exhaust valve guide in order to achieve the correct valve stem-to-guide clearance.
4. Always recondition the exhaust valve seat after reaming the exhaust valve guide bores and installing new exhaust valves.

**Inspect**

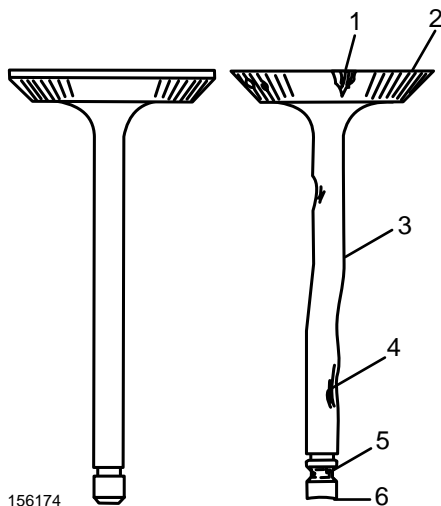

156174

5. Inspect the valves for the following:
  - Burnt or damaged areas (1)
  - Undersize margin (2)
  - Bent stem (3)
  - Scoring or other damage to the stem (4)
  - Worn key groove (5)
  - Worn stem tip (6)

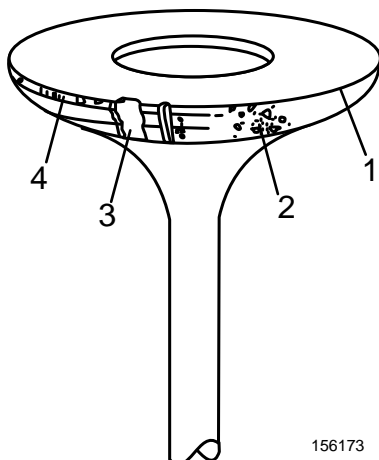

156173

6. Inspect the valve contact surface for the following:
  - Undersized margin (1)
  - Pitted surfaces (2)
  - Burnt or eroded areas (3)
  - Acceptable edge (margin) (4)

Valves with excessive damage must be replaced.

Minor imperfections of the valve or valve seat may be repaired.

7. Reconditioning of the valves and valve seats:
  - The valves must seat perfectly for the engine to deliver optimum power and performance.
  - Cooling the valve heads is another important factor. Good contact between each valve and valve seat in the cylinder head is

necessary to insure that the heat in the valve head is properly carried away.

- Regardless of what type of equipment is used, it is essential that the valve guide bores are free from carbon or dirt in order to ensure the proper centering of the pilot in the valve guide.

The valve seats should be concentric to within 0.05 mm (0.002 in) total indicator reading.

- Reface pitted valves on a valve refacing machine in order to ensure the correct relationship between the valve head and the valve stem.
- Replace the valve if the valve stem is excessively worn or warped.
- Replace the valve if the edge margin (4) of the valve head is less than 0.79 mm (0.031 in) thick after grinding.

Several different types of equipment are available for reconditioning valves and valve seats. Follow the equipment manufacturer's recommendations for equipment use to attain the proper results.

### Valve Rocker Arm Stud Removal

Tools Required

J5802 Rocker Arm Stud Remover

**Note! Valve rocker arm ball studs that have damaged threads or are loose in the cylinder heads should be replaced.**

1. Place the J 5802-01 over the valve rocker arm ball stud to be removed.
2. Install a nut and a flat washer.
3. Rotate clockwise to remove the valve rocker arm ball stud.

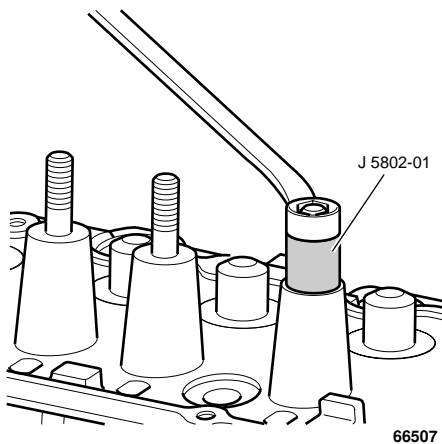

### Valve Rocker Arm Stud Installation

Tools Required

J5715 Reamer (0.0762 mm (0.003 in)

J 6036 Reamer (0.0332 mm (0.013 in)

J 6880 Rocker Arm Stud Installer

1. Ream the hole to the proper size for the replacement oversize valve rocker arm ball stud. Use J 5715 for 0.0762 mm (0.003 in) oversize valve rocker arm ball studs or J 6036 for 0.03302 mm (0.013 in) oversize valve rocker arm ball studs.
2. Apply lubricant GM P/N 1052271 or equivalent to the lower end (press-fit end) of the valve rocker arm ball stud.

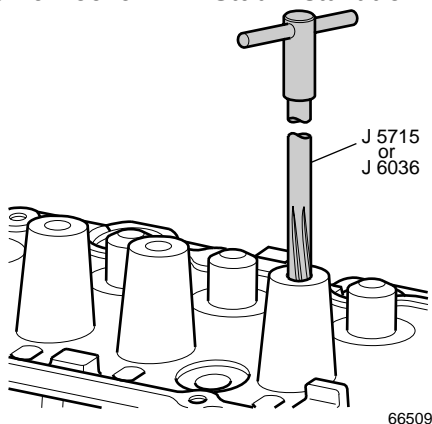

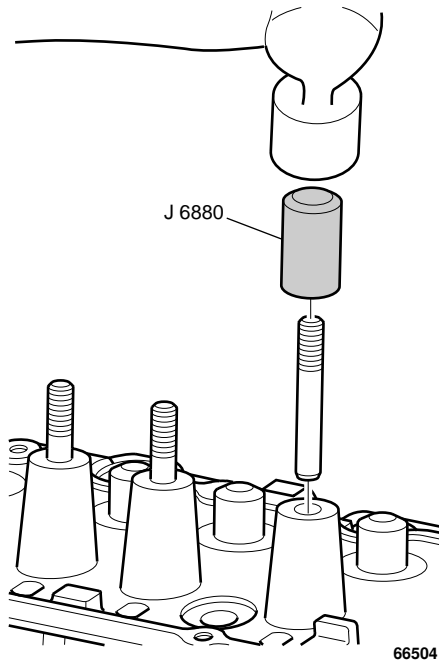

Cylinder Head Assemble

3. Use J 6880 and a hammer to install the valve rocker arm ball stud into place. The valve rocker arm ball stud is installed to proper depth when the J 6880 bottoms onto the cylinder head.

Tools Required

- J 8062 Valve Spring Compressor
- J 42073 Valve Stem Seal Installer

**Note!** The exhaust valve oil stem seal has the letters EX (1) molded into the top of the seal. The exhaust valve oil stem seal material is brown in color (2) with a white stripe (3) painted onto the outside diameter of the seal, or the material may be red in color (2) with no paint stripe. The intake valve oil seal is black in color.

Install Oil Seal

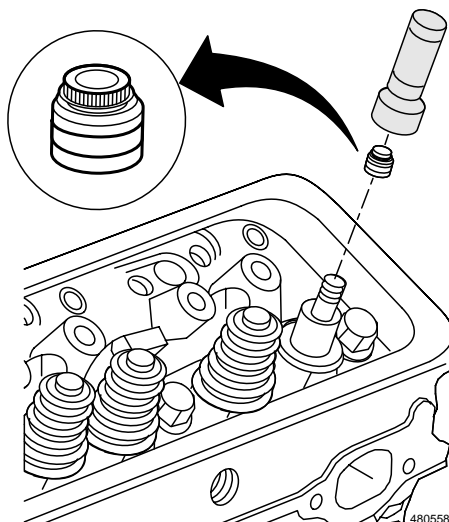

1. Assemble the valve into the proper valve guide.
2. Select the proper valve stem oil seal for the specific valve guide.
3. Lubricate the valve stem oil seal and the outside diameter of the valve guide with clean engine oil.
4. Assemble the valve stem oil seal onto the valve stem.



**Caution!**

**Wear Safety Glasses.**

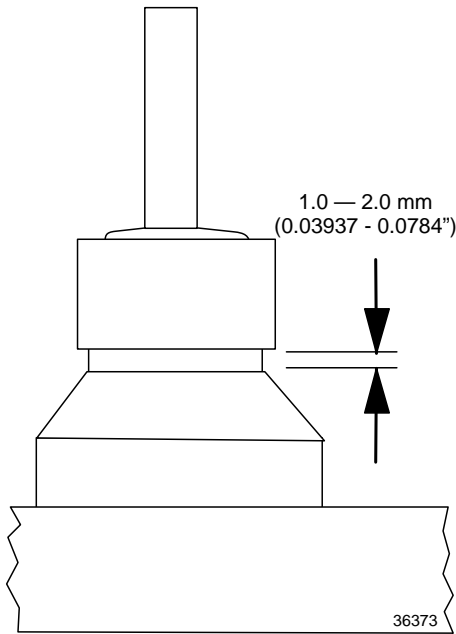

5. Install the valve stem oil seal onto the valve guide using the J-42073. Tap the valve stem oil seal onto the valve guide until the J-42073 bottoms against the valve spring seat.
6. Inspect the valve stem oil seal. The valve stem oil seal should not be bottomed against the valve guide.

There should be a 1-2 mm (0.03937-0.07874 in) gap between the bottom edge of the valve stem oil seal and the valve guide.

**Install Valve Spring**

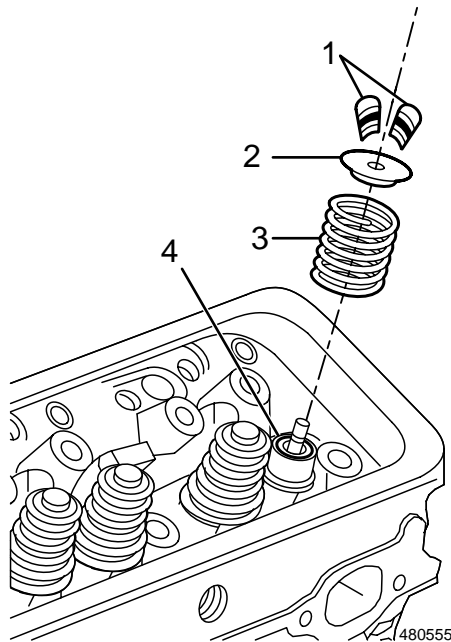

7. Install the valve spring (3).
8. Install the valve spring cap (2) onto the valve spring (3) and over the valve stem.



**Warning!**

**Wear Safety Glasses. Compressed valve springs have high tension against the valve spring compressor. Valve springs that are not properly compressed by or released from the valve spring compressor can be ejected from the valve spring compressor with intense force. Use care when compressing or releasing the valve spring with the valve spring compressor and when removing or installing the valve stem keys. Failing to use care may cause personal injury.**

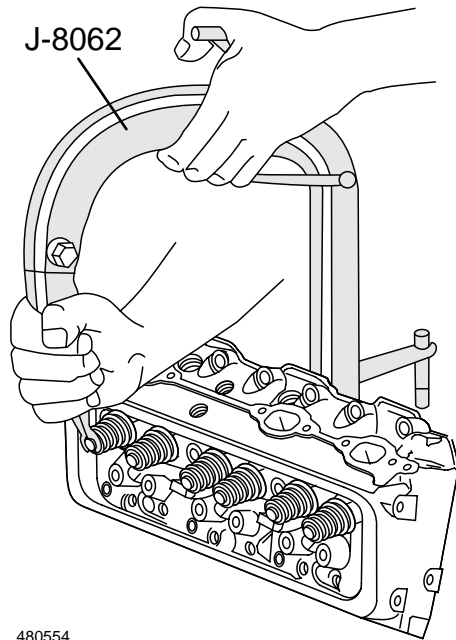

480554

9. Use the J 8062 in order to compress the valve springs.
10. Install the valve stem keys.
  - a. Use grease in order to hold the valve stem keys in place while disconnecting the J 8062.
  - b. Look to ensure that the valve stem keys seat properly in the upper groove of the valve stem.
  - c. Tap the end of the valve stem with a plastic-faced in order to seat the valve stem keys, if necessary.

**Installation**

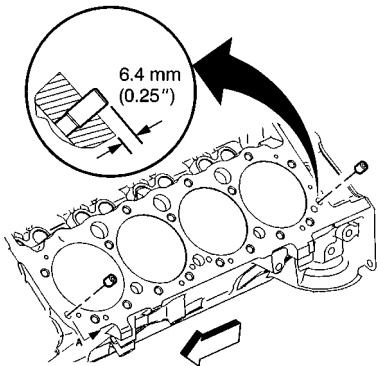

182846

1. Clean the cylinder head gasket surfaces on the engine block.
2. Inspect the dowel pins (cylinder head locators) for proper installation.
3. Clean the cylinder head gasket surfaces on the cylinder heads.



**Caution!**

**Do not use any sealer on the cylinder head gaskets.**

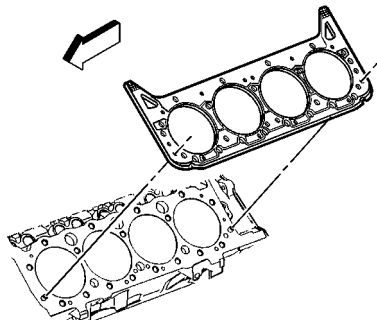

317233

4. Install NEW cylinder head gaskets in position over the locator pins.

5. Install the cylinder head onto the cylinder block. Guide the cylinder head carefully into position over the locator pins and the cylinder head gasket.

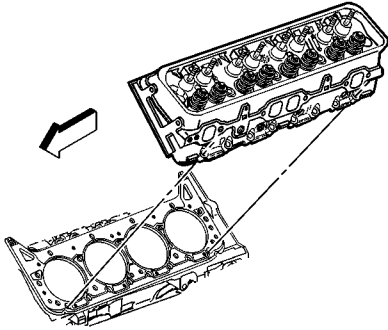

317227

6. Apply sealant 1141570 or equivalent to the threads of the cylinder head bolts.
7. Install the cylinder head bolts finger tight.

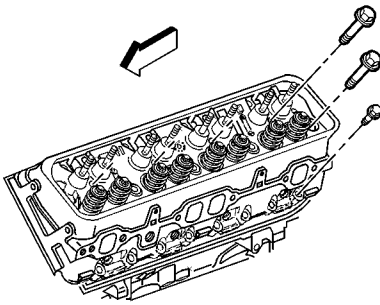

317217

**Tighten:**

Tighten the cylinder head bolts in sequence in two steps.

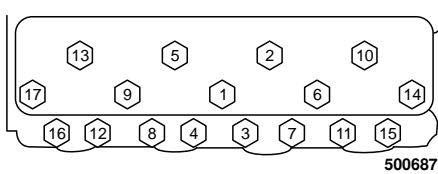

1. First step, 30 N•m (22 ft. lb.)
2. Final step use special tool J 36660 and tighten as follows;
  - a. Tighten the long bolts (1, 2, 5, 6, 9, 10 and 13) on the final step sequence to 75 degrees.
  - b. Tighten the middle length bolts (14 and 17) on the final step sequence to 65 degrees.
  - c. Tighten the short length bolts (3, 4, 7, 8, 11, 12, 15 and 16) on the final step sequence to 55 degrees.

3. Install New spark plugs adjusted to the proper gap.
4. Install Rocker Arm Cover, Rocker Arm Cover” on page 72.

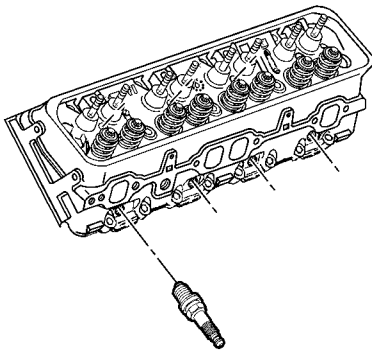



## Oil Pan and Oil Pump

### Removal

1. Drain oil from engine. "Draining The Engine" on page 54
2. Remove engine from boat, "Engine Specifications" on page 155.
3. Disconnect and remove the dipstick tube. Discard the O-rings (1) and seals (2).

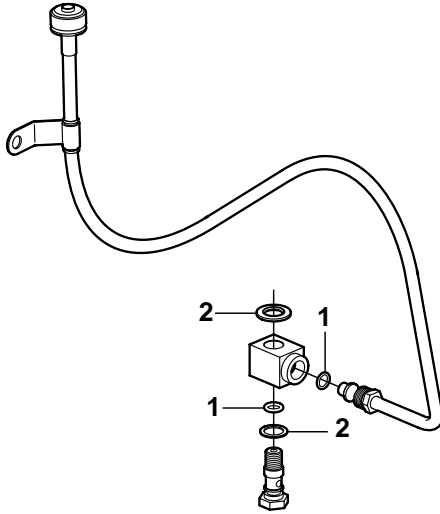

182850

4. Remove the oil pan bolts and nuts.
5. Remove the oil pan.

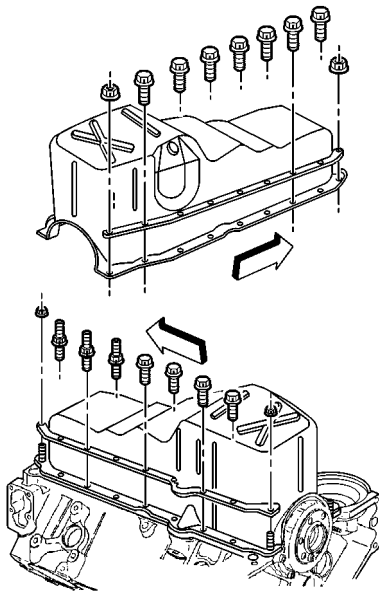

182851

6. Remove and discard the oil pan gasket.

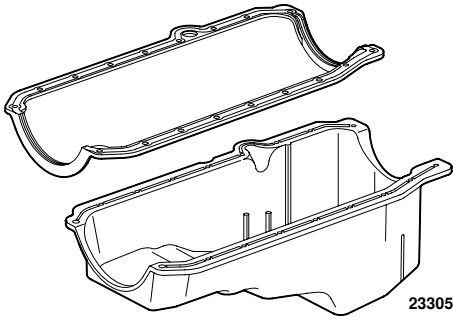

### Oil Pan Clean and Inspect

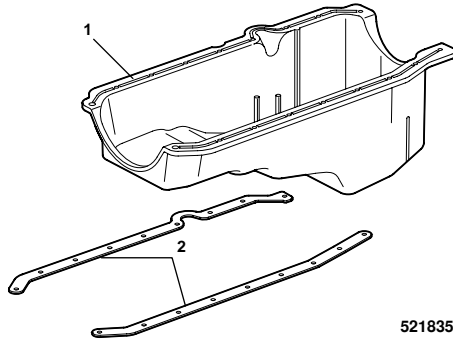

### Caution

#### Wear Safety Glasses.

1. Clean the oil pan baffle in cleaning solvent.
2. Dry the oil pan and the oil pan baffle with compressed air.
3. Inspect the oil
  - Gouges or damage to the oil pan sealing surfaces (1)
  - The oil pan drain plug hole for damaged threads
  - Damaged oil pan drain plug threads
  - Damage to the oil pan reinforcements (2)
  - Damage to the oil pan baffle
  - Dents or damage to the exterior of the oil pan

An oil pan that is dented may interfere with the proper position of the oil pump screen, or may not distribute oil properly in the oil pan sump area.

### Oil Pump Removal

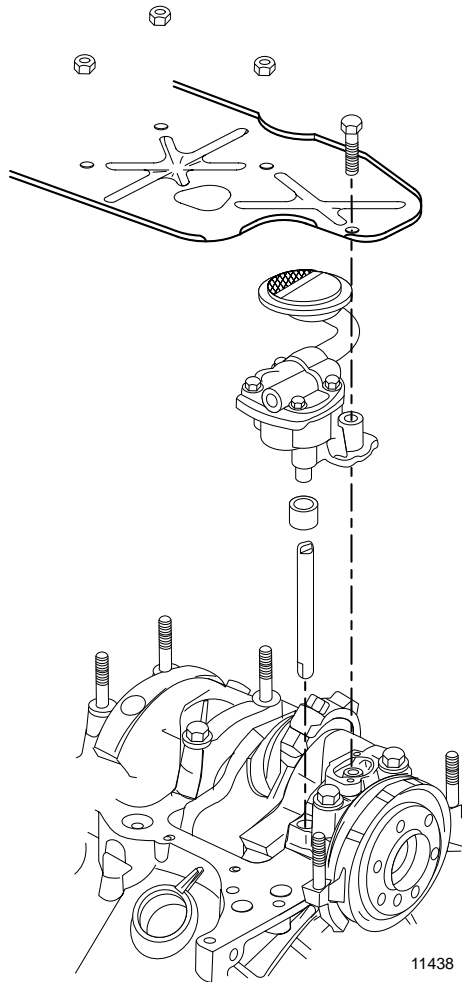

1. Remove the nuts (6) and the crankshaft oil deflector (2).
  2. Remove the oil pump bolt (1).
  3. Remove the oil pump (3), the oil pump driveshaft (5) and the oil pump driveshaft retainer (4).
  4. Separate the oil pump (3), the oil pump driveshaft (5) and the oil pump driveshaft retainer (4).
- Note! Always install a NEW oil pump driveshaft retainer during assembly.**
5. Discard the oil pump driveshaft retainer.

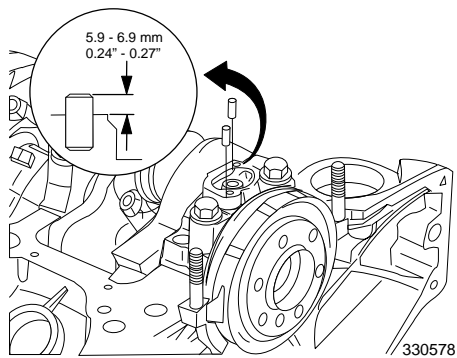

6. Inspect the pins (oil pump locator) for damage, and replace if required.

### Oil Pump Disassemble

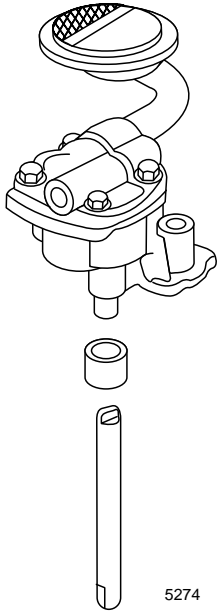

1. Remove the oil pump driveshaft and retainer.

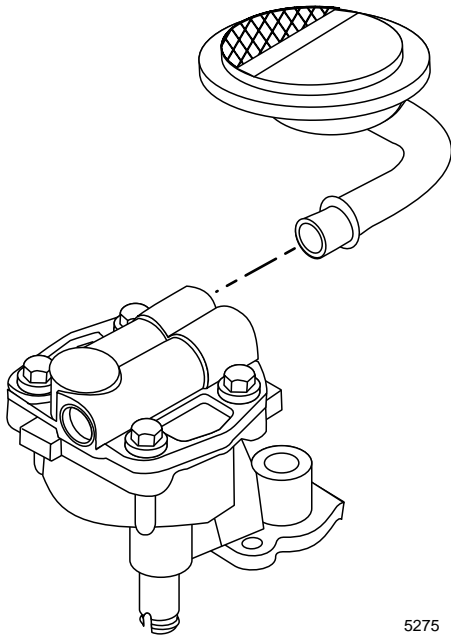

2. Remove oil pump screen (if necessary)
  - The oil pump screen has a press fit into the oil pump cover.
  - DO NOT remove the oil pump screen from the pipe. The pipe and oil pump screen are serviced as a unit.

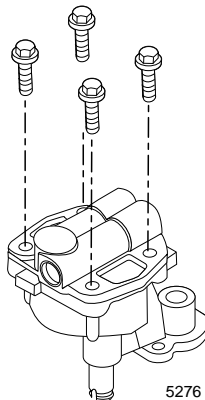

3. Remove the oil pump cover bolts

- Remove the oil pump cover

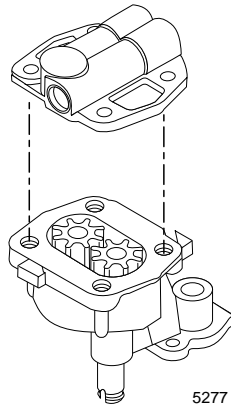

- Remove the oil pump drive gear and the oil pump driven gear.
- Match mark the gears for reassembly.

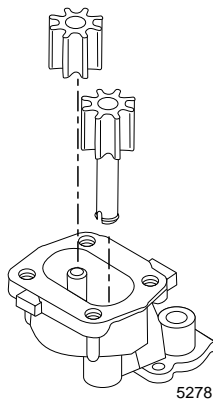

- Remove the oil pressure relief valve retaining pin (1)
- Remove the oil pressure relief spring (2).
- Remove the oil pump pressure relief valve (3).

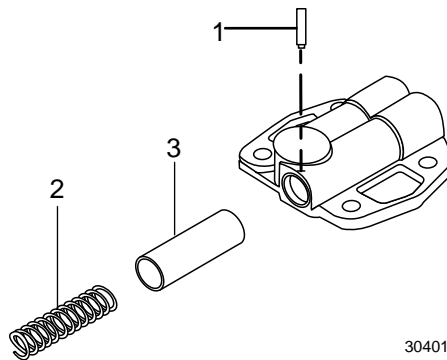

### Oil Pump Clean and Inspect

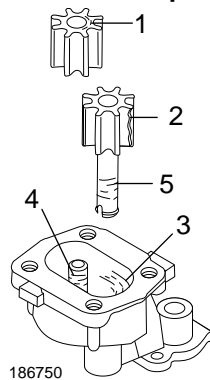

### **Warning! Wear safety glasses**

- Clean the oil pump components in cleaning solvent.
- Dry the components with compressed air.
- Inspect the oil pump for the following conditions:
  - Scoring on the top of the gears (1)
  - Damaged gears (2) for the following:
    - Chipping
    - Galling
    - Wear
  - Scoring, damage or casting imperfections to the body (3)

- Damaged or scored gear shaft (4)
  - Damaged or scored gear shaft (5)
  - Damaged bolt hole threads
  - Worn oil pump driveshaft bore
  - Damaged or sticking oil pump pressure relief valve (minor imperfections may be removed with a fine oil stone)
  - Collapsed or broken oil pump pressure relief valve spring
4. If the oil pump is to be reused, install a NEW oil pump pressure relief valve spring.
  5. During oil pump installation, install a NEW oil pump driveshaft retainer.

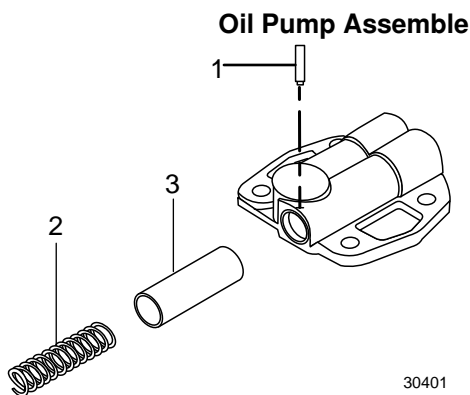

**Tools Required**

J 21882 Oil Suction Pipe Installer

1. Apply clean engine oil GM P/N 12345610 or equivalent to the oil pump pressure relief valve, oil pump pressure relief valve spring and oil pump body.



**Caution! Wear Safety Glasses.**

**Note! Replace the oil pump pressure relief valve spring when you reuse the oil pump.**

2. Install the following items:
  - a. The oil pump pressure relief valve
  - b. The oil pump pressure relief valve spring
  - c. The oil pump pressure relief valve spring straight pin
3. Apply clean engine oil GM P/N 12345610 or equivalent to the oil pump drive gear, the oil pump driven gear and the oil pump body internal surfaces.
4. Install the oil pump drive gear and the oil pump driven gear into the oil pump body.
  - a. Align the match marks on the oil pump drive and driven gears.
  - b. Install the smooth side of the oil pump drive and driven gears toward the oil pump cover.

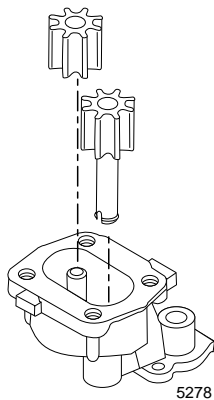

5. Install the pump cover.

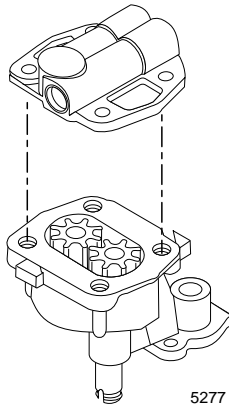

6. Install the oil pump cover bolts. Tighten the bolts to 12 N•m (106 lb. in).
7. Inspect the oil pump for smoothness of operation by turning the oil pump driveshaft by hand.

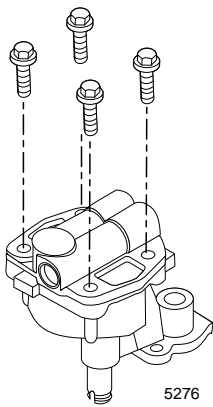

8. Install the oil pump screen.
  - a. If removed, replace the oil pump screen.
  - b. The oil pump screen must have a good press fit into the oil pump body.
  - c. Mount the oil pump in a soft jawed vise.
  - d. Apply sealant 1141570 or equivalent to the end of the oil pump screen pipe.
  - e. Use the J 21882 and a soft-faced hammer in order to tap the oil pump screen into the pump body.
9. The oil pump screen must align parallel with the bottom of the oil pan when the oil pan is installed.

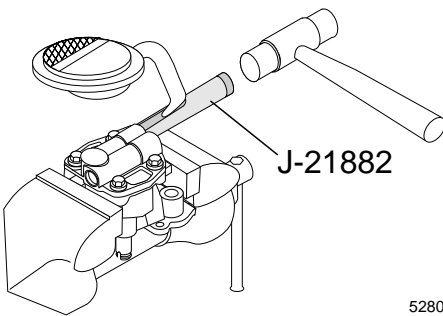

**Oil Pump, Pump Screen and Deflector Installation**

1. Inspect for properly installed pins (oil pump locator).

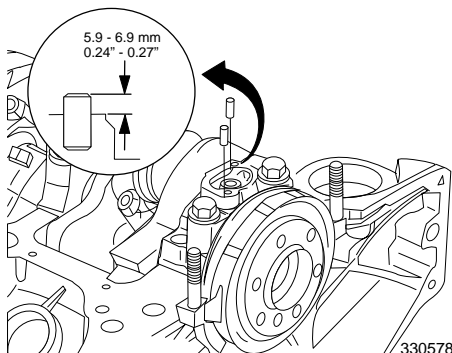

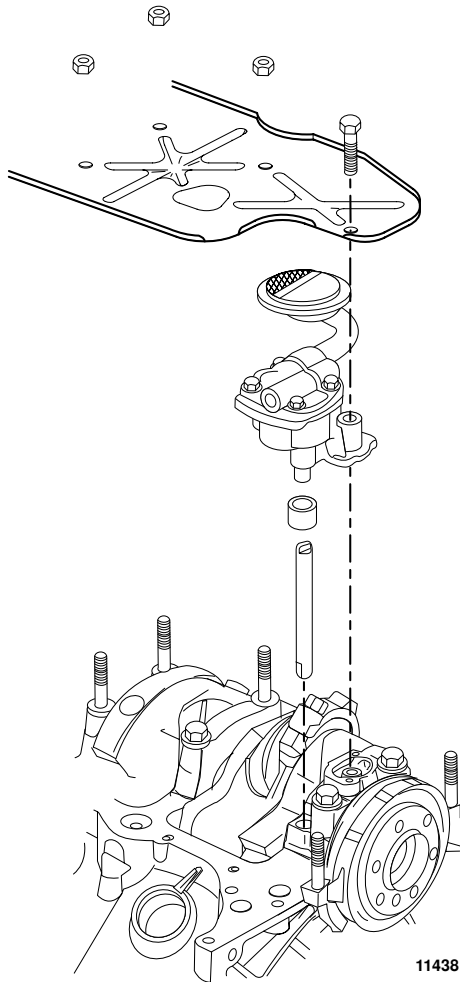

**Note! DO not reuse the oil pump driveshaft retainer (4).**

During assembly, install a NEW oil pump driveshaft retainer.

2. Assemble the oil pump (3), the oil pump driveshaft (5) and a NEW oil pump driveshaft retainer (4).

3. Install the oil pump (3).

Position the oil pump onto the pins.

4. Install the crankshaft oil deflector (2) and the nuts (6).

5. Install the bolt (1) attaching the oil pump to the rear crankshaft bearing cap.

Tighten

- Tighten the oil pump bolt on the first pass to 20 N.m (15 lb. ft.).
- Tighten the oil pump bolt on the final pass to 65 degrees using the J 36660.
- Tighten the crankshaft oil deflector nuts to 40 N.m (30 lb. ft.).

### Oil Pan Installation

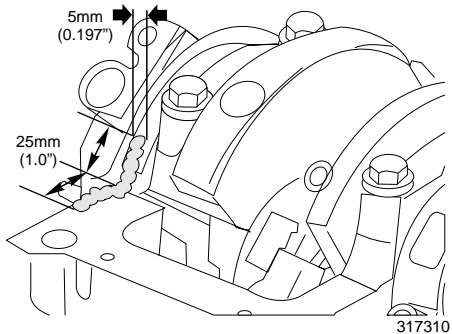

1. Apply a 5 mm (0.197 in) wide and 25 mm (1.0 in) long bead of adhesive Volvo Penta P/N 1161277 or equivalent to both the right and left sides of the engine front cover to engine block junction at the oil pan sealing surfaces.

2. Install the oil pan studs into the engine block if removed.

Tighten

3. Tighten the oil pan studs to 6 N.m (53 lb. in).



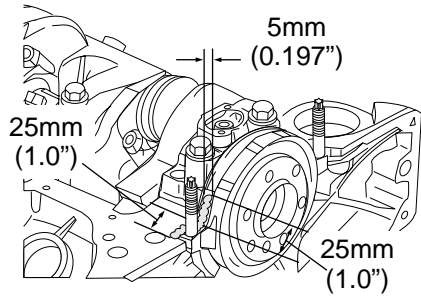

317313

4. Apply a 5 mm (0.197 in) wide and 25 mm (1.0 in) long bead of adhesive Volvo Penta P/N 1161277 or equivalent to both the right and left sides of the crankshaft rear oil seal housing to engine block junction at the oil pan sealing surfaces.

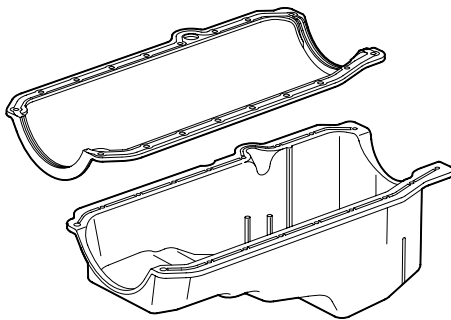

23305

**Note! Always install a NEW oil pan gasket.**

The oil pan gasket and oil pan must be installed and the fasteners tightened while the adhesive is still wet to the touch.

5. Install the NEW oil pan gasket into the groove in the oil pan.
6. Install the oil pan onto the engine block.  
Press the oil pan gasket into the grooves of the engine front cover and crankshaft rear oil seal housing.
7. Slide the oil pan back against a suitable straight edge.

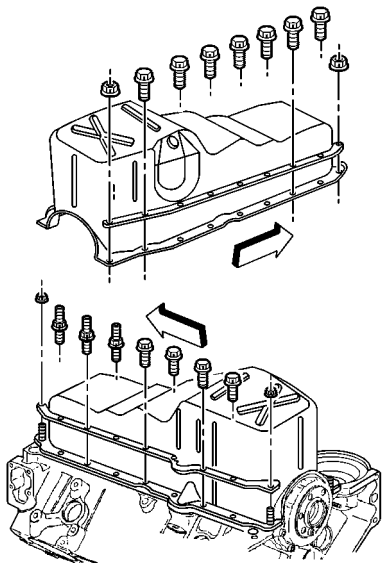

182851

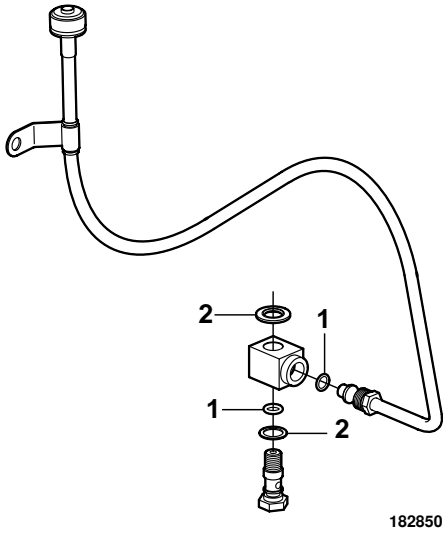

8. Using new seals and O-rings, install the dipstick tube. Tighten bolt to 25 N•m (18 ft. lb.)

**Note!** Always use new seals and O-rings when the dipstick is removed.

## Water Pump

GXi

### Removal

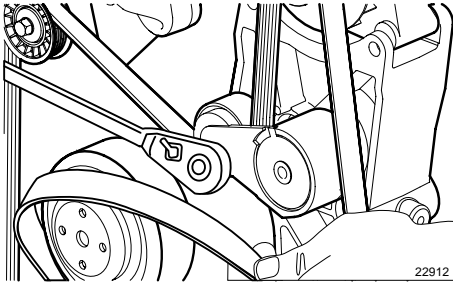

### Tools Required

J41240 Fan Clutch Remover and Installer

1. Release tension on the bent tensioner and remove the serpentine belt from the water pump pulley.

**Note!** It is not necessary to remove the belt from the rest of the other pulleys unless the belt is worn or deteriorated.

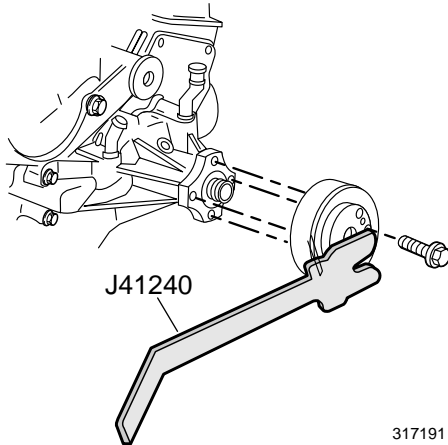

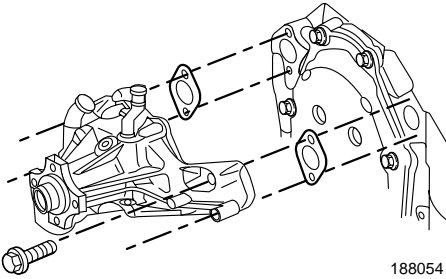

188054

3. Remove the water pump bolts.
4. Remove the water pump.
5. Remove and discard the water pump gaskets.

**Inspection**

The circulation pump is not a serviceable unit. Replace the circulation pump if necessary.

**Installation**

**Tools Required**

J41240 Fan Clutch Remover and Installer

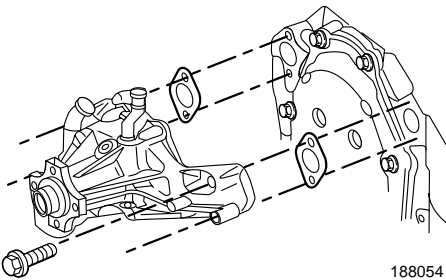

188054

1. If reusing the fasteners, apply sealant 1141570 or equivalent to the threads of the water pump bolts.
2. Clean any residual gasket material from cooling ports on the engine. If reusing the circulation pump, clean any residual gasket material from the face of the mounting ports.
3. Install the water pump and the NEW water pump gaskets.
4. Install the water pump bolts and tighten to 45 N.m (33 lb. ft.).
5. Install the fan and water pump pulley and bolts using the J41240 or suitable substitute.
6. Tighten the and water pump pulley bolts to 25 N.m (18 lb. ft.).

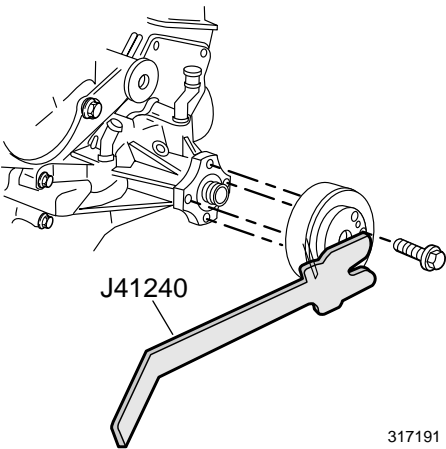

J41240

317191

7. Release the belt tensioner and reinstall the serpentine belt.



**Caution!**

**Be sure the belt is aligned on the grooved pulleys before operating the engine. The belt life will be significantly shortened if the belt is misaligned on the grooved pulleys**

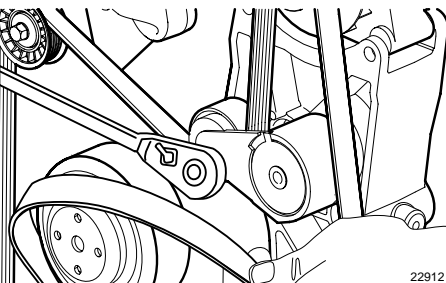

22912  
22912

**GL**

- Remove**
1. Loosen power steering pump nut.

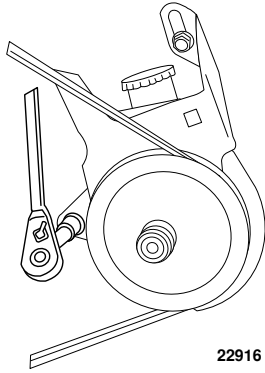

2. Loosen power steering pump bolt.

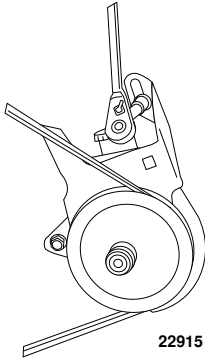

3. Loosen power steering pump pivot nut.
4. Pull up on power steering pump belt to loosen belt tension and remove the belt.

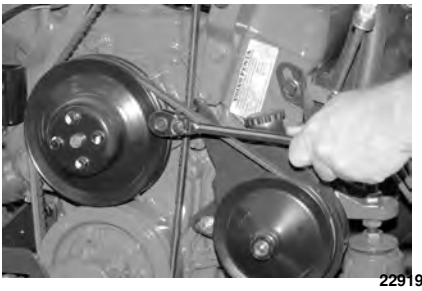

5. Loosen alternator pivot bolt.





22918

6. Loosen alternator belt tension bolt.
7. Pull on alternator belt to loosen the alternator and remove the belt.

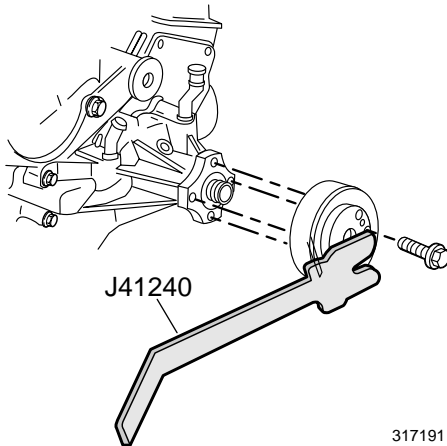

317191

**Tools Required**

J 41240 Fan Clutch Remover and Installer

8. Remove the bolts and the fan and water pump pulley using the J41240.
9. Remove the water pump bolts.
10. Remove the water pump
11. Remove the water pump gaskets.
12. Discard the water pump gaskets.

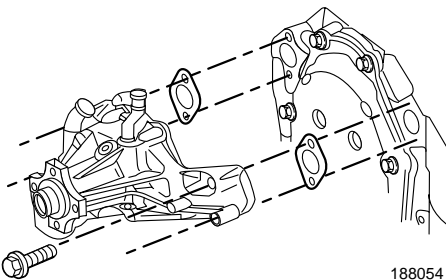

188054

**Water Pump Installation**

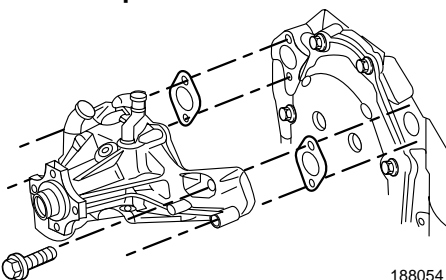

188054

**Tools Required**

J 41240 Fan Clutch Remover and Installer

1. If reusing the fasteners, apply sealant 1141570 or equivalent to the threads of the water pump bolts.
  2. Install the water pump and the NEW water pump gaskets.
- Notice: Refer to Fastener Notice in Cautions and Notices.**
3. Install the water pump bolts. Tighten the water pump bolts to 45 N.m (33 lb. ft.).

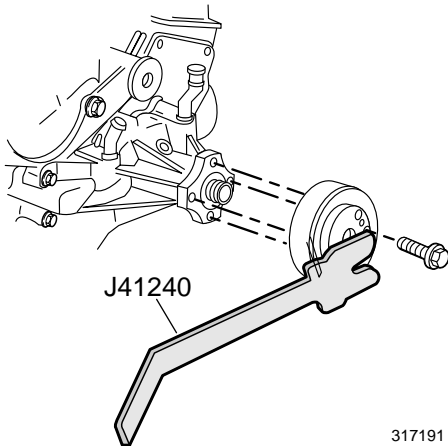

4. 5. Install the fan and water pump pulley and bolts using the J41240. Tighten the fan and water pump pulley bolts to 25 N.m (18 lb. ft.).

Tools Required

5. Install Alternator belt.



**Caution!**

**Do not substitute automotive belts. Belts used for the alternator, circulating pump, and power steering pump are heavy-duty.**

6. Tighten alternator belt to  $33,6 \pm 2,7$  N ( $75 \pm 10$  lb.) or 6,4 mm ( $\frac{1}{4}$  in.) deflection with light pressure on belt. Check belt tension midway between the water pump pulley and the alternator pulley (2).
7. Install power steering pump belt.

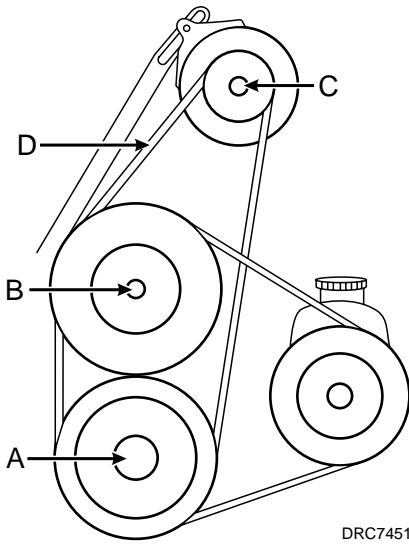

8. Tighten power steering belt to  $33,6 \pm 2,7$  N ( $75 \pm 10$  lb.) or 6,4 mm ( $\frac{1}{4}$  in.) deflection with light pressure on belt. Check belt tension midway between the water pump pulley and the power steering pump pulley (1).



## Crankshaft Balancer

### Removal

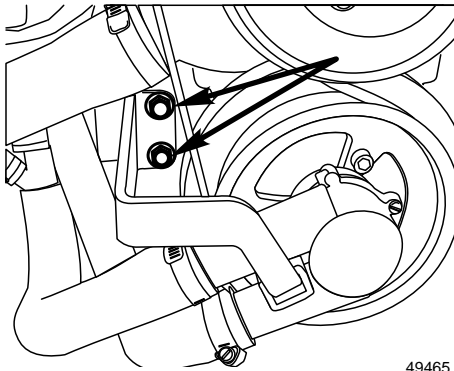

49465

1. Remove bolts from the pump holding bracket and remove the bracket.

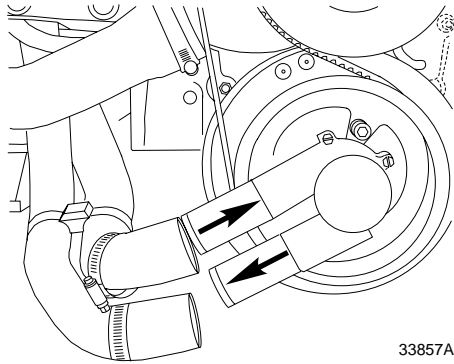

33857A

2. Disconnect hoses from raw water pump.

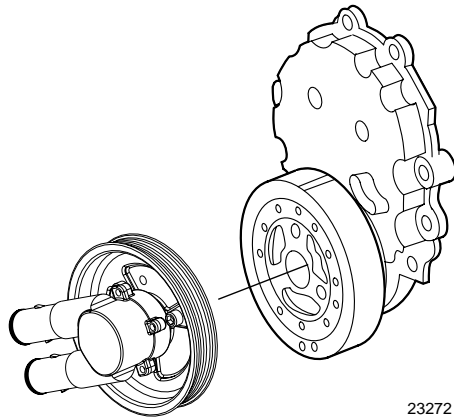

23272

3. Remove raw water pump retaining bolts and remove the pump.

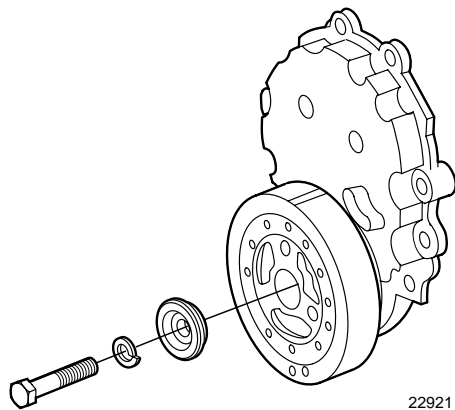

22921

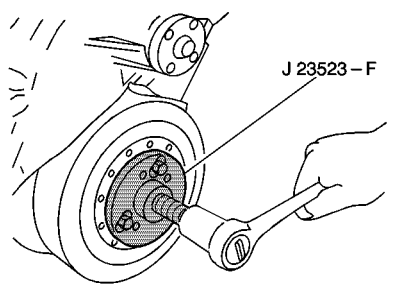

4059

### Crankshaft Balancer Inspect

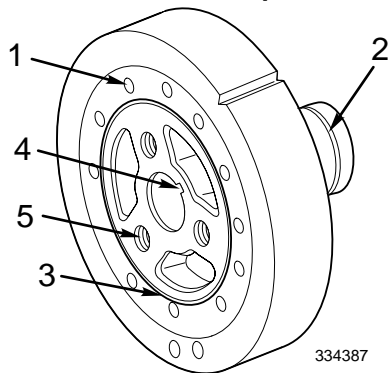

334387

4. Remove the crankshaft balancer bolt and washer.

### Tools Required

J23523-F Balancer Remover and Installer.

5. Use the J23523-F in order to remove the crankshaft balancer.
  - a. Install the J 23523-F plate and bolts onto the crankshaft balancer. Tighten the bolts to 25 N•m (18 lb. ft.).
  - b. Install the J 23523-F forcing screw into the plate.
  - c. Rotate the J 23523-F forcing screw clockwise in order to remove the crankshaft balancer.
6. Remove the J23523-F from the crankshaft balancer.

1. Clean the crankshaft balancer in cleaning solvent.
2. Dry the crankshaft balancer with compressed air.
3. Inspect the crankshaft balancer for the following:
  - Loose or improperly installed front groove pin (1)(crankshaft balancer). A properly installed front groove pin should be installed until flush or below flush with the face of the crankshaft balancer.

Important: A crankshaft front oil sealing surface with excessive scoring, grooves, rust or other damage must be replaced.

- Worn, grooved or damaged crankshaft front oil sealing surface (2). Minor imperfections on the crankshaft balancer crankshaft front oil seal surface may be removed with a polishing compound or fine grade emery cloth.
- Worn, chunking or deteriorated rubber (3) between the hub and the outer ring
- Worn or damaged keyway (4)
- Worn or damaged bolt hole threads (5)

### Crankshaft Balancer Installation

### Tools Required

J 23523-F Balancer Remover and Installer



### Caution!

The inertial weight section of the crankshaft balancer is assembled to the hub with a rubber type material. The cor-



**rect installation procedures (with the proper tool) must be followed or movement of the inertial weight section of the hub will destroy the tuning of the crankshaft balancer.**

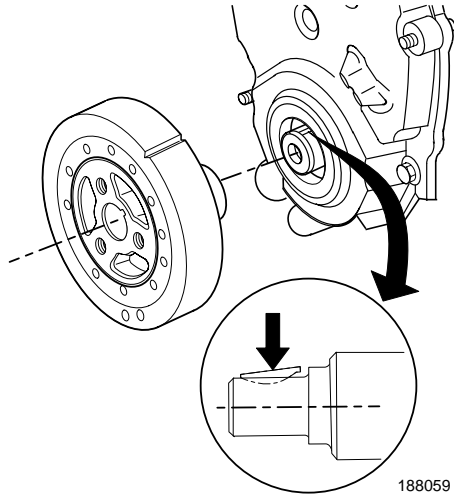

1. Apply a small amount of adhesive Volvo Penta P/N 1161277 or equivalent onto the crankshaft balancer keyway in order to seal the crankshaft balancer keyway and crankshaft joint.
2. Align the keyway of the crankshaft balancer with the crankshaft balancer key.
3. Install the crankshaft balancer onto the end of the crankshaft.

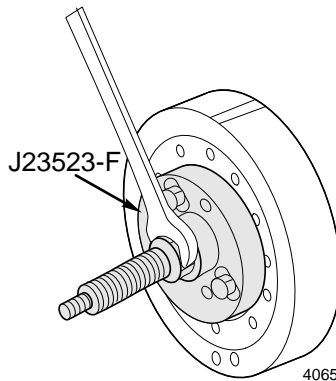

4. Use the J 23523-F in order to press the crankshaft balancer onto the crankshaft.
  - a. Install the J 23523-F plate and bolts onto the front of the crankshaft balancer. Tighten the J23523-F plate bolts to 25 N•m (18 lb. ft.).
  - b. Install the J 23523-F screw into the end for the crankshaft.
  - c. Install the J 23523-F bearing, the washer and the nut onto the J 23523-F screw.
  - d. Rotate the J 23523-F nut clockwise until the crankshaft balancer hub is completely seated against the crankshaft position sensor reluctor ring.

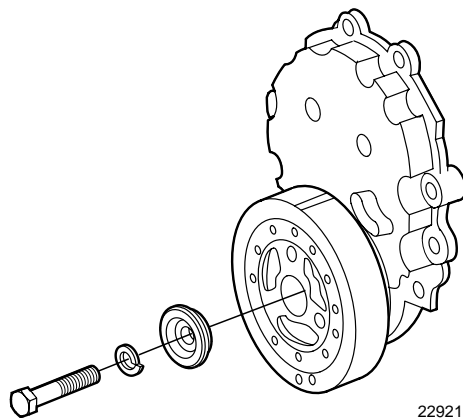

5. Remove the J23523-F.
6. Install the balancer bolt, lock washer, and centering washer. Tighten the balancer bolt to 58 N•m (43 lb. ft.).

7. Install raw water pump and pulley. Tighten bolts to 33-39 N•m (25-29 ft. lb.)

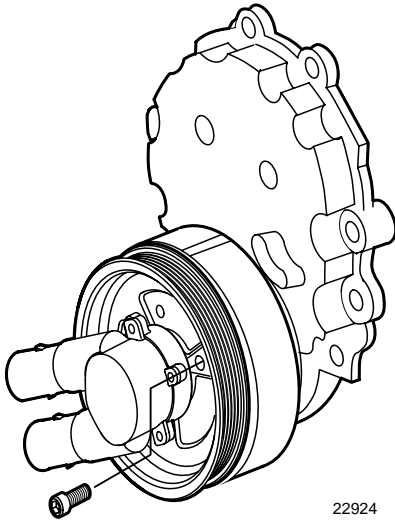

8. Install water pump retaining bracket

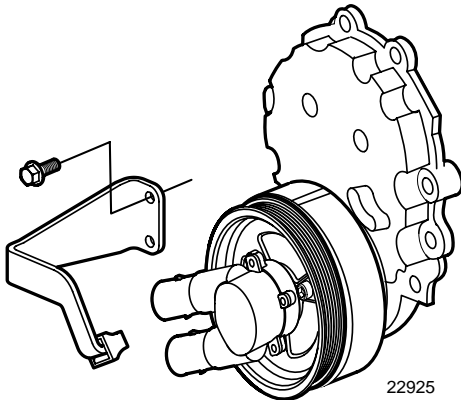

9. Install water hoses in the correct orientation and tighten clamps



**Caution!**

**Crossing the raw water hoses will damage the water pump impeller and engine.**

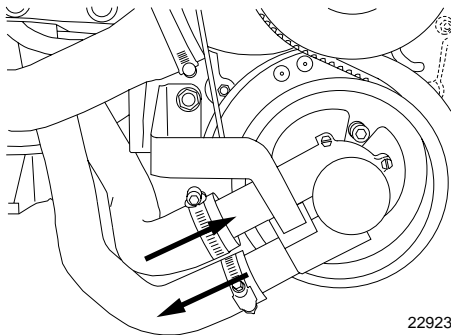

## Engine Front Cover

Remove engine, See “Engine Removal” on page 223..

Remove engine circulation pump, Water Pump” on page 100.

Remove crankshaft balancer and engine raw water pump, Crankshaft Balancer” on page 105.

Remove oil pan, See “Oil Pan and Oil Pump” on page 91.

**Removal**

1. Remove the crankshaft position sensor bolt.
2. Remove the crankshaft position sensor.

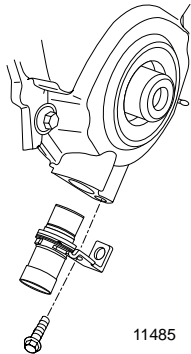

3. Remove and discard the crankshaft position sensor seal (O-ring).

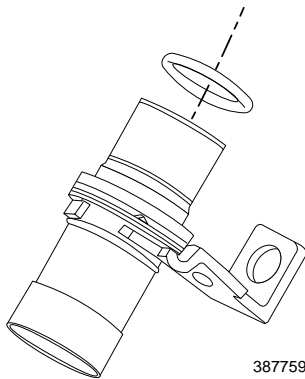

4. Remove engine front cover bolts and front cover.



**Caution!** The engine front cover is made of composite material and has an intergral gasket. Once the front cover is removed, it must be discarded and a new front cover must be used.

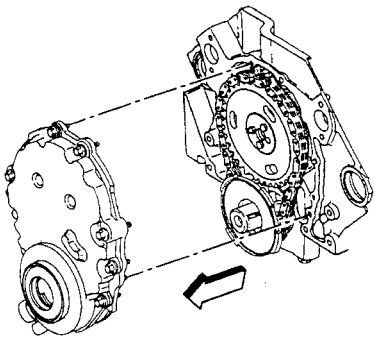

**Engine Front Cover Installation**



**Caution!** The engine front cover is made of composite material and has an intergral gasket. Once the front cover is removed, it must be discarded and a new front cover must be used.

1. 1.Install the NEW engine front cover.
2. 2.Install the engine front cover bolts and tighten to 12 N•m (106 lb. in).

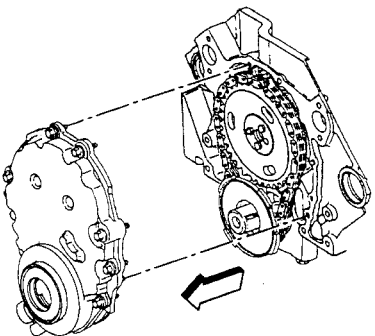

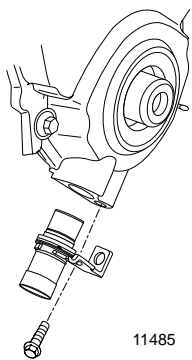
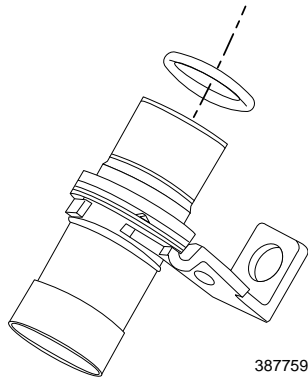

**Caution! DONOT reuse the original crankshaft position sensor seal (o-ring). When installing the crankshaft position sensor, be sure the crankshaft position sensor is fully seated and held stationary in the engine front cover crankshaft position sensor bore. A crankshaft position sensor that is not completely seated will cock in the engine front cover and may result in erratic engine operation.**

3. Lubricate the NEW crankshaft position sensor seal (O-ring) with clean engine oil.
4. Install the NEW crankshaft position sensor seal (O-ring) onto the crankshaft position sensor.
5. Install the crankshaft position sensor until fully seated into the engine front cover.
6. Install the crankshaft position sensor bolt and tighten to 9 N•m (80 lb. in).
7. Install oil pan, Oil Pan and Oil Pump” on page 91.
8. Install crankshaft balancer, Crankshaft Balancer” on page 105.
9. Install engine circulation pump, Water Pump” on page 100.
10. Install engine in boat, Engine Installation” on page 228.

## Timing Chain and Sprocket

### Removal

#### Tools Required

J 5825-A Crankshaft Gear Remover

1. Remove engine front cover, Engine Front Cover” on page 108.
2. Remove the crankshaft position sensor reluctor ring.

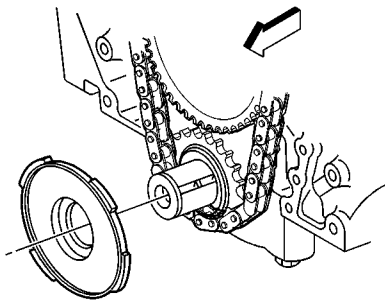

3. Check the camshaft timing chain free play.
  - a. Rotate the camshaft sprocket (1) counterclockwise until all slack is removed from the camshaft timing chain (2).
  - b. Measure the free play on the slack side (3) of the camshaft timing chain. If the camshaft timing chain can be moved side to side in excess of 11 mm (0.43 in), replacement of the camshaft timing chain and the sprockets is recommended during assembly.

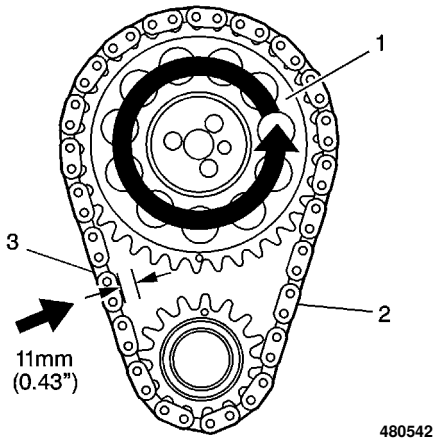

4. Remove the camshaft sprocket bolts.
5. Remove the camshaft sprocket and the camshaft timing chain.

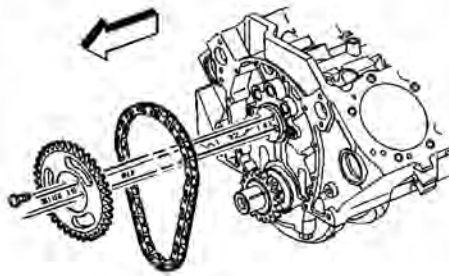

6. Remove the crankshaft sprocket using the J 5825-A.

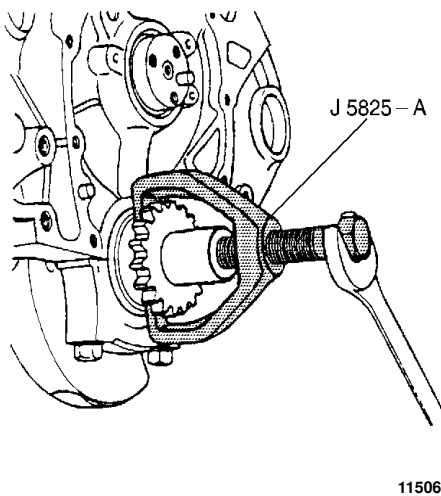

7. Remove the crankshaft balancer key.

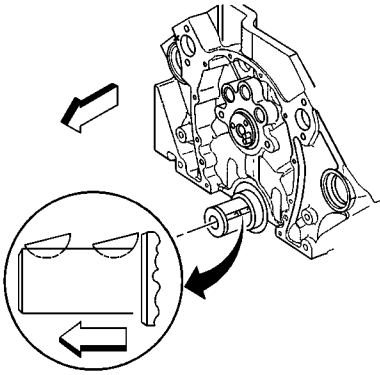

182847

**Inspection**



**Caution! Wear safety glasses when using compressed air.**

1. Clean the components with cleaning solvent.
2. Dry the components with compressed air.
3. Inspect the camshaft timing chain for binding or wear.

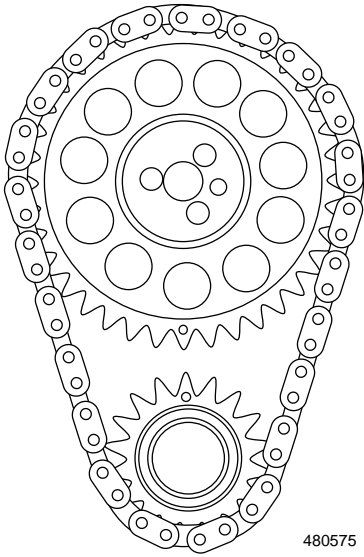

480575

4. Inspect the camshaft sprocket and the crankshaft sprocket for the following:

- Broken teeth (1)
- Damaged teeth (2)
- Chipped teeth (3)
- Worn teeth
- Uneven wear on the edge of the teeth
- Worn valleys between the sprocket teeth

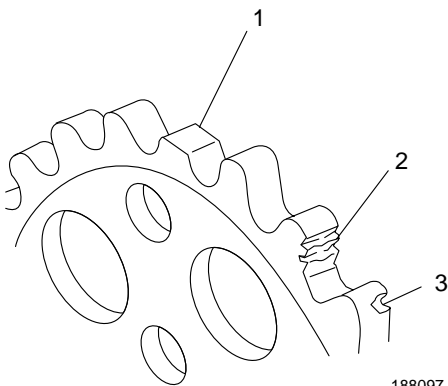

188097

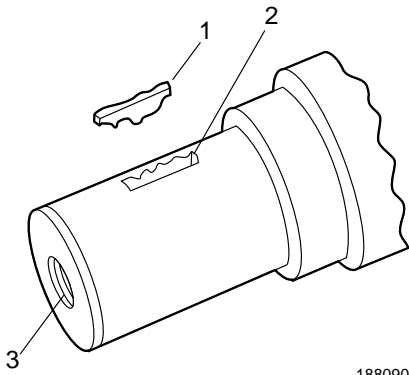

188090

5. Inspect the crankshaft balancer key (1), the keyway (2) and the threaded hole (3) for damage.
6. Repair or replace the crankshaft as necessary.

**Installation**

**Tools Required**

J 5590 Installer

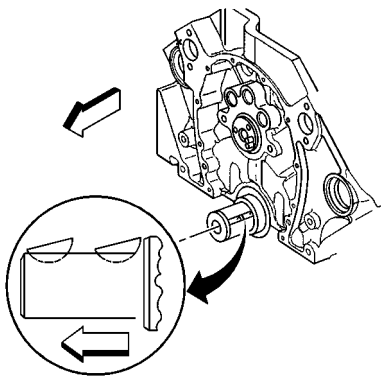

182847

1. Install the crankshaft balancer key into the crankshaft keyway.
  - The crankshaft balancer key should be parallel to the crankshaft or with a slight incline.

2. Align the keyway of the crankshaft sprocket with the crankshaft balancer key.



**Caution: Wear Safety Glasses**

3. Use the J 5590 to install the crankshaft sprocket.

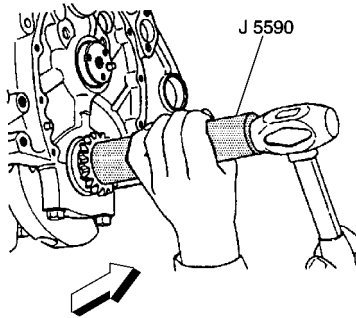

32066

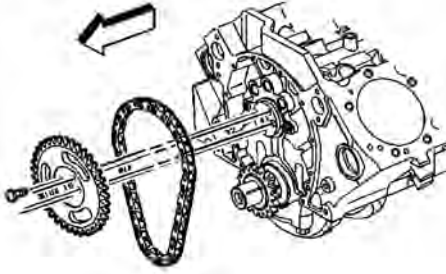

500645

4. Rotate the crankshaft until the crankshaft sprocket is at the 12 o'clock position.
5. Install the camshaft sprocket and the camshaft timing chain.
6. Install the camshaft sprocket bolts and tighten to 25 N•m (18 lb. ft.).



**Caution!**

**Do not use a hammer to install the camshaft sprocket onto the camshaft. To do so may dislodge the expansion cup plug (camshaft rear bearing hole).**

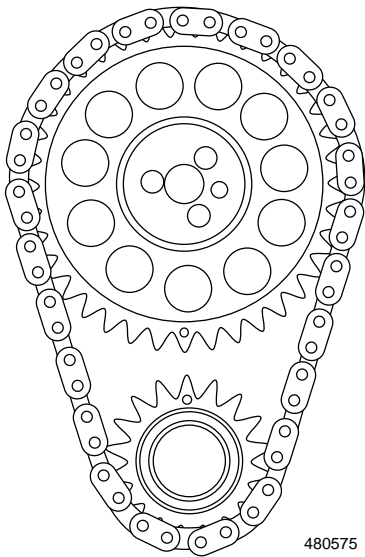

480575



**Caution!**

**Install the camshaft sprocket with the alignment mark at the 6 o'clock position.**

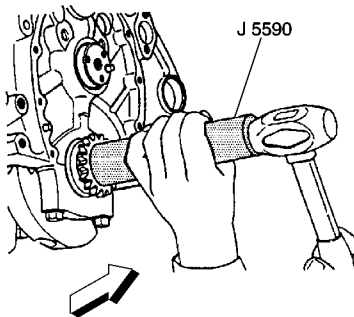

32066

7. Install the crankshaft position sensor reluctor ring.
  - a. Align the keyway on the crankshaft position sensor reluctor ring with the crankshaft balancer key in the crankshaft.
  - b. Use the J 5590 in order to push the crankshaft position sensor reluctor ring onto the crankshaft until completely seated against the crankshaft sprocket.
8. Install front cover, "Engine Front Cover" on page 108.

**Camshaft**

**Remove**

1. Remove timing chain and sprockets, "Timing Chain and Sprocket" on page 110.



2. Remove intake manifold, Intake Manifold” on page 58
3. Remove valve lifters, Valve Train” on page 72
4. Remove the camshaft retainer bolts and retainer.

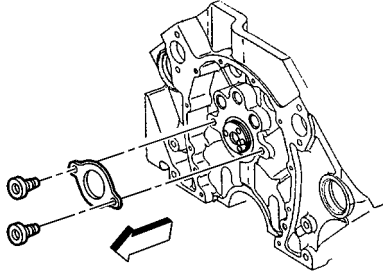

182836

**Note!** All camshaft journals are the same diameter, so care must be used in removing or installing the camshaft to avoid damage to the camshaft bearings.

5. Remove the engine camshaft.
  - a. Install the three 5/16-18 x 4.0 inch bolts into the engine camshaft front bolt holes.
  - b. Using the bolts as a handle, carefully rotate and pull the engine camshaft out of the camshaft bearings.
  - c. Remove the bolts from the front of the engine camshaft.

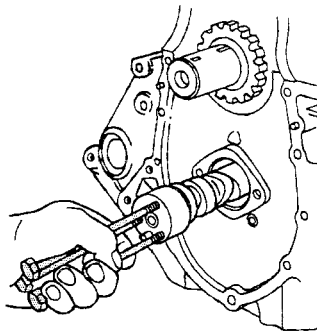

69013

**Inspect** Tools Required

J 7872 Magnetic Base Dial Indicator

**⚠ Warning! Wear Safety Glasses.**

1. Clean the engine camshaft in cleaning solvent.
2. Dry the engine camshaft with compressed air.
3. Inspect the camshaft retainer plate for damage.

If the camshaft retainer plate is damaged, replace as necessary.

4. Inspect the camshaft bearings for correct fit into the engine block camshaft bearing bores.

**⚠ Caution! The camshaft bearings have an interference fit to the engine block camshaft bearing bores and must not be loose in the engine block camshaft bearing bores.**

**Note! If any camshaft bearing is excessively worn or scored, replace all the camshaft bearings.**

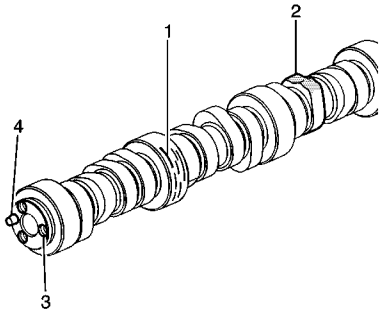

188095

5. Inspect the camshaft bearings for excessive wear or scoring.
6. Inspect the engine camshaft for the following:
  - Worn, scored or damaged bearing journals (1)
  - Worn engine camshaft lobes (2)
  - Damaged bolt hole threads (3)
  - Damaged camshaft sprocket locator pin (4)

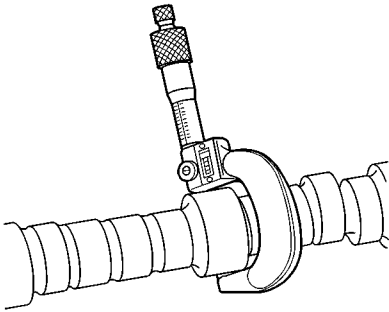

188014

7. Measure the engine camshaft journals with a micrometer.  
If the camshaft journals are more than 0.025 mm (0.0010 in) out-of-round, then replace the engine camshaft.

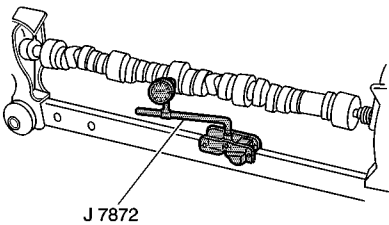

J 7872

188012

8. Measure for a bent engine camshaft or excessive engine camshaft run-out using the J 7872.
  - a. Mount the engine camshaft in a suitable stand between centers.
  - b. Use the J 7872 in order to check the intermediate engine camshaft journals.
9. Measure the engine camshaft lobe lift using the J 7872.
  - a. Place the engine camshaft on the V-blocks.
  - b. Use the J 7872 in order to measure the engine camshaft lobe lift.
10. Replace the engine camshaft if the engine camshaft lobe lift is not within specifications. Refer to Engine Mechanical Specifications.

**Installation**

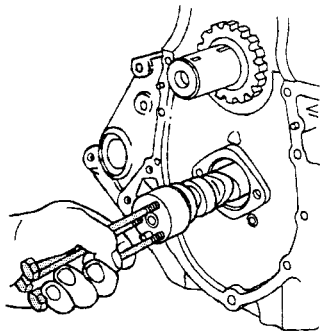

69013

1. Apply clean engine oil GM P/N 12345610 or equivalent, or engine oil supplement GM P/N 1052367 or equivalent to the following components:
  - The engine camshaft lobes
  - The camshaft bearing journals
  - The camshaft bearings
2. Install three 5/16-18 x 4.0 in. bolts into the engine camshaft front bolt holes.



**Caution! All camshaft journals are the same diameter, so care must be used in removing or installing the camshaft to avoid damage to the camshaft bearings.**

3. Use the bolts as a handle in order to install the engine camshaft.
4. Remove the 3 bolts from the front of the engine camshaft.
5. Install the timing chain and sprockets, Timing Chain and Sprocket” on page 110.
6. Install the valve lifters, Valve Train” on page 72.
7. Install the intake manifold, Intake Manifold” on page 58.

**Camshaft Bearings**

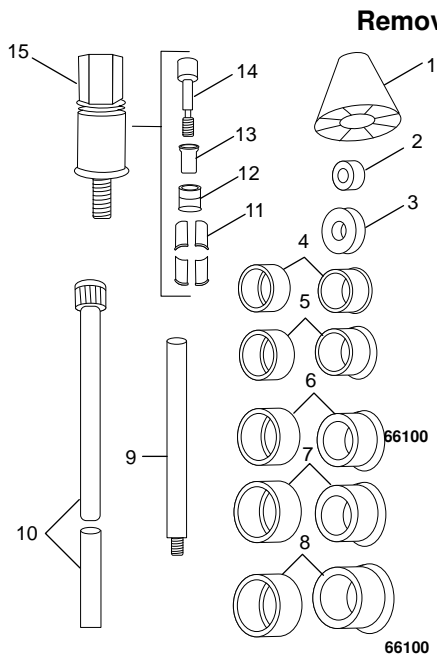

**Remove**

**Tools Required**

J 33049 Camshaft Bearing Service Kit

1. Remove camshaft, Camshaft” on page 114.
2. Select the cone (1), the handle (10), the expanding driver (4-8), the washer (2 or 3) and the expander assembly (15) from the J 33049.
3. Assemble the J 33049.

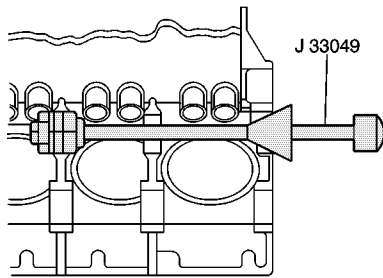

4985

**Note!** A loose camshaft bearing may be caused by an enlarged, out-of-round or damaged engine block camshaft-bearing bore.

**Note!** Always remove the camshaft inner bearings #2 and #3 first. The camshaft outer bearings #1 and #4 serve as a guide for the J 33049.



**Caution! Wear Safety Glasses**

4. Remove the camshaft inner bearings #2, #3 and #4.
  - a. Insert the J 33049 through the front of the engine block and into the camshaft inner bearing #2.
  - b. Tighten the J 33049 expander assembly nut until snug.
  - c. Push the J 33049 guide cone into the camshaft front bearing in order to align the J 33049.
  - d. Drive the camshaft inner bearing #2 from the camshaft inner bearing bore #2.
  - e. Loosen the J 33049 expander assembly nut.
  - f. Remove the camshaft inner bearing #2 from the J 33049 expander assembly.
  - g. Insert the J 33049 expander assembly into the camshaft inner bearing #3.
  - h. Tighten the J 33049 expander assembly nut until snug.
  - i. Push the J 33049 guide cone into the camshaft front bearing in order to align the J 33049.
  - j. Drive the camshaft inner bearing #3 from the camshaft inner bearing bore #3.
  - k. Loosen the J 33049 expander assembly nut.
  - l. Remove the camshaft inner bearing #3 from the J 33049 expander assembly.
  - m. Insert the J 33049 expander assembly into the camshaft inner bearing #4.
  - n. Tighten the J 33049 expander assembly nut until snug.
  - o. Push the J 33049 guide cone into the camshaft front bearing in order to align the J 33049.
  - p. Drive the camshaft inner bearing #4 from the camshaft inner bearing bore #4.
  - q. Loosen the J 33049 expander assembly nut.
  - r. Remove the camshaft inner bearing #4 from the J 33049 expander assembly.
5. Remove the J 33049 from the engine block.

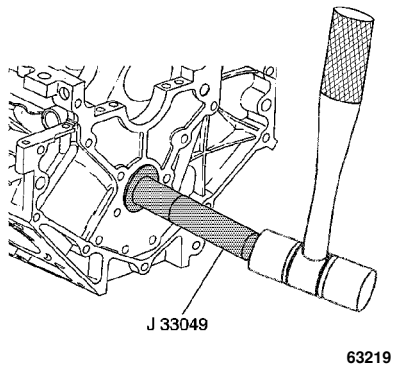

6. Remove the camshaft outer bearings #1 and #5.
  - a. Insert the J 33049 into the camshaft outer bearing #1.
  - b. Tighten the J 33049 expander assembly nut until snug.
  - c. Drive the camshaft outer bearing #1 from the camshaft outer bearing bore #1.
  - d. Loosen the J 33049 expander assembly nut.
  - e. Remove the camshaft outer bearing #1 from the J 33049 expander assembly.
  - f. Remove the J 33049 from the engine block.
  - g. Insert the J 33049 expander assembly into the camshaft outer bearing #5.
  - h. Tighten the J 33049 expander assembly nut until snug.
  - i. Drive the camshaft outer bearing #5 from the camshaft outer bearing bore #5.
  - j. Loosen the J 33049 expander assembly nut.
  - k. Remove the camshaft outer bearing #5 from the J 33049 expander assembly.
7. Remove the J 33049 from the engine block.
8. Discard the camshaft bearings.

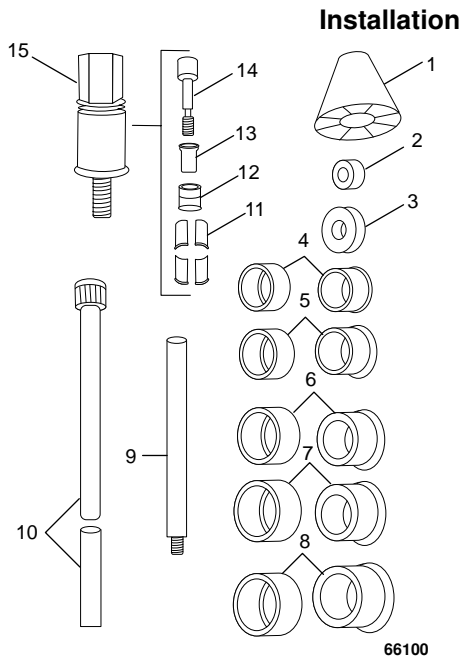

Tools Required

J 33049 Camshaft Bearing Service Kit



**Caution!**

**Always install the camshaft outer bearings #1 and #5 first. The camshaft outer bearings serve as a guide for the J 33049 and help center the camshaft inner bearings during the installation process.**

**Ensure that the camshaft bearing lubrication hole or holes align with the oil gallery hole or holes in the engine block. On some engines, the oil gallery holes may be difficult to see. Verify that the camshaft bearing lubrication holes and the oil gallery holes are aligned.**

1. Select the handle (10), the expanding driver (4-8), the washer (2 or 3) and the expander assembly (15) from the J 33049.
2. Assemble the J 33049

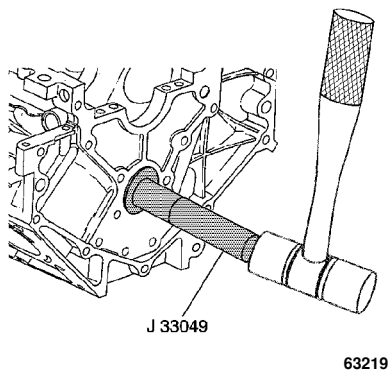

**⚠ Caution! Wear Safety Glasses.**

**Note! The camshaft bearings vary in size. When ordering the new camshaft bearings, be sure to order the correct camshaft bearings for the application to be serviced.**

**Note! Always install the camshaft outer bearings #1 and #4 first. The camshaft outer bearings serve as a guide for the J 33049 and help center the camshaft inner bearings during the installation process.**

3. Install the NEW camshaft outer bearings #5 and #1.
  - a. Install the NEW camshaft outer bearing #4 onto the J33049 expander assembly.
  - b. Tighten the J 33049 expander assembly nut until snug.
  - c. Align the camshaft outer bearing #5 lubrication hole with the oil gallery hole in the camshaft outer bearing bore #5 at the rear of the engine block.
  - d. Drive the camshaft outer bearing #5 into the camshaft outer bearing bore #5 at the rear of the engine block.
  - e. Loosen the J 33049 expander assembly nut.
  - f. Remove the camshaft outer bearing #5 from the J33049 expander assembly.
  - g. Install the NEW camshaft outer bearing #1 onto the J33049 expander assembly.
  - h. Tighten the J 33049 expander assembly nut until snug.
  - i. Align the camshaft outer bearing #1 lubrication hole with the oil gallery hole in the camshaft outer bearing bore #1 at the front of the engine block
  - j. Drive the camshaft outer bearing #1 into the camshaft outer bearing bore #1 at the front of the engine block.
  - k. Loosen the J 33049 expander assembly nut.
  - l. Carefully slide the J 33049 into the engine block until the J 33049 expander assembly is positioned between the camshaft inner bearing bore #3 and the camshaft inner bearing bore #4.

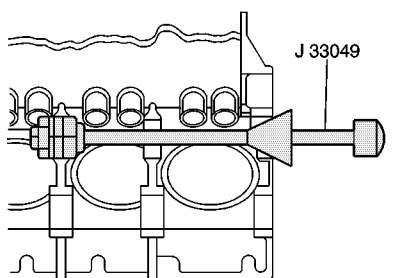

4. Install the NEW camshaft inner bearings #4, #3 and #2.
  - a. Install the NEW camshaft inner bearing #4 onto the J33049 expander assembly.
  - b. Tighten the J 33049 expander assembly nut until snug.
  - c. Align the camshaft inner bearing #4 lubrication hole with the oil gallery hole in the camshaft inner bearing bore #4 of the engine block.
  - d. Push the J 33049 guide cone into the camshaft front bearing bore #1 in order to align the J 33049.
  - e. Drive the camshaft inner bearing #4 into the camshaft inner bearing bore #4.
  - f. Loosen the J 33049 expander assembly nut.

- g. Carefully slide the J 33049 until the J 33049 expander assembly is positioned between the camshaft inner bearing bore #3 and the camshaft inner bearing bore #2.
  - h. Install the NEW camshaft inner bearing #3 onto the J33049 expander assembly.
  - i. Tighten the J 33049 expander assembly nut until snug.
  - j. Align the camshaft inner bearing #3 lubrication hole with the oil gallery hole in the camshaft inner bearing bore #3 of the engine block.
  - k. Push the J 33049 guide cone into the camshaft front bearing bore #1 in order to align the J 33049.
  - l. Drive the camshaft inner bearing #3 into the camshaft inner bearing bore #3.
  - m. Loosen the J 33049 expander assembly nut.
  - n. Carefully slide the J 33049 until the J 33049 expander assembly is positioned between the camshaft inner bearing bore #2 and the camshaft outer bearing bore #1.
  - o. Install the NEW camshaft inner bearing #2 onto the J33049 expander assembly.
  - p. Tighten the J 33049 expander assembly nut until snug.
  - q. Align the camshaft inner bearing #2 lubrication hole with the oil gallery hole in the camshaft inner bearing bore #2 of the engine block.
  - r. Push the J 33049 guide cone into the camshaft front bearing bore #1 in order to align the J 33049.
  - s. Drive the camshaft inner bearing #2 into the camshaft inner bearing bore #2.
  - t. Loosen the J 33049 expander assembly nut.
5. Install camshaft, See “Camshaft” on page 114..

## Piston, Connecting Rod, and Bearings

1. Remove engine from boat, Engine Specifications” on page 155.
2. Remove cylinder heads, Cylinder Head” on page 79.
3. Remove oil pan, Oil Pan and Oil Pump” on page 91.

### Tools Required

J 5239 Connecting Rod Bolt Guide Set

J 24270 Cylinder Bore Ridge Reamer

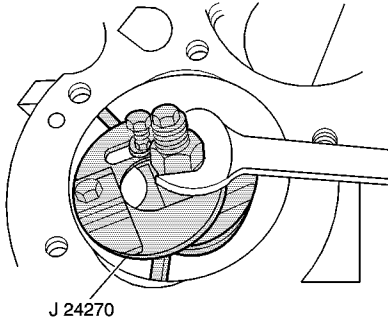

11497

4. Use the J 24270 in order to remove the cylinder ring ridge.
  - a. Turn the crankshaft until the piston is at the bottom of the stroke.
  - b. Place a cloth on top of the piston.
  - c. Use the J 24270 to remove all of the cylinder ring ridge.
  - d. Turn the crankshaft so the piston is at the top of the stroke.
  - e. Remove the cloth.
  - f. Remove the cutting debris.

**Note! Place match marks or numbers on the connecting rods and the connecting rod caps.**

5. Remove the connecting rod nuts.
6. Remove the connecting rod cap.

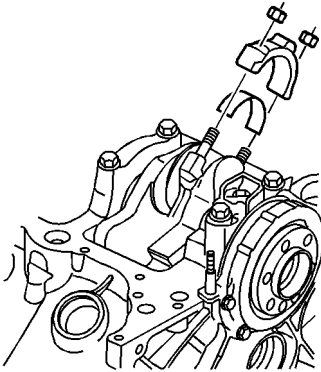

7. Use the J 5239 in order to protect the crankshaft journals and remove the connecting rod and the piston out of the top of the engine block.

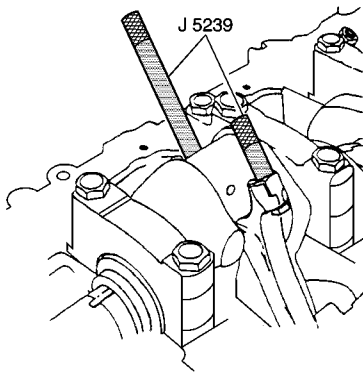



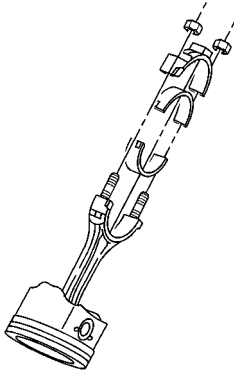

**⚠ Caution! Always assemble the connecting rod caps to the matching connecting rods.**

8. Remove the connecting rod bearings.
  - a. Keep the connecting rod bearings with the original connecting rod and connecting rod cap.
  - b. Wipe the oil from the connecting rod bearings.
  - c. Wipe the oil from the crank-pins.

**Piston and Connecting Rod Disassemble**

Tools Required

J 24086-C Piston Pin Remover/Installer

**⚠ Caution! Wear Safety Glasses.**

1. Remove the piston rings from the pistons.



4967

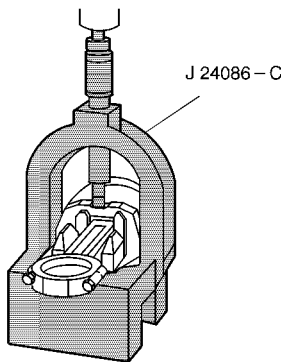

4965

2. Press the piston pin from the connecting rod using the J 24086-C.
3. The piston pin has an interference fit into the connecting rod, and is full floating in the piston.

4. Mark separate, and organize the parts for assembly.

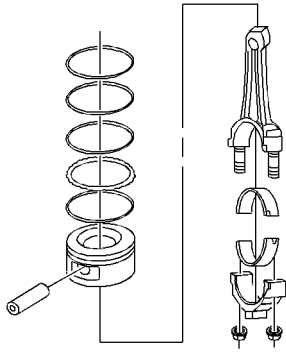

34671

### Clean and Inspect

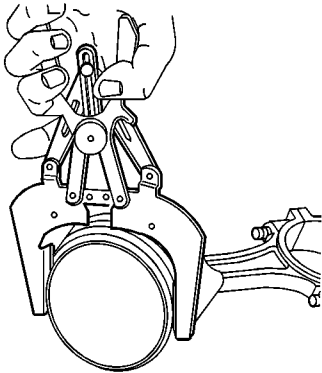

4977

**Note!** Measurement of all components should be taken with the components at room temperature.



**Caution!** Do not use a wire brush in order to clean any part of the piston. Particles from the wire will become embedded in the piston and damage the cylinder and piston.



**Caution!** Wear Safety Glasses.

1. Clean the piston and connecting rod in solvent.
2. Dry the components with compressed air.

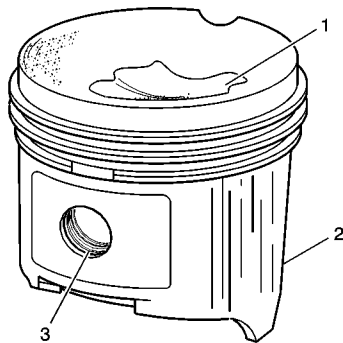

156168

3. Clean the piston oil lubrication holes and slots.
4. Inspect the piston for the following:
  - Eroded areas (1) on the top of the piston
  - Scuffed or damaged skirt (2)
  - Damage to the pin bore (3)
  - Cracks in the piston ring lands, the piston skirt or the pin bosses
  - Piston ring grooves for nicks, burrs or other warping which may cause the piston ring to bind
5. Inspect the piston pin for scoring, wear or other damage

6. Measure the piston ring-to-piston ring groove side clearance.
  - d. Insert the edge of the piston ring into the piston ring groove.
  - e. Roll the piston ring completely around the piston.
    - If binding is caused by a distorted piston ring groove, MINOR imperfections may be removed with a fine file.
    - If binding is caused by a distorted piston ring, replace the piston ring.

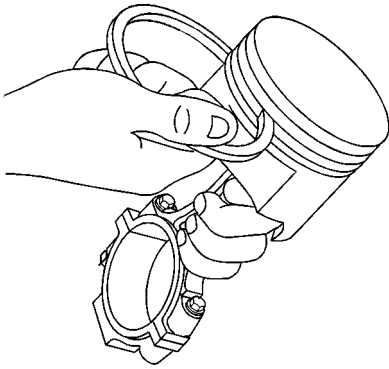

4969

7. Measure the piston ring side clearance with a feeler gauge.
8. If the side clearance is too small, try another piston ring set.
9. If the proper piston ring-to-piston ring groove clearance cannot be achieved, replace the piston and pin assembly.
10. To determine the proper piston ring side clearance, Engine Specifications” on page 155.

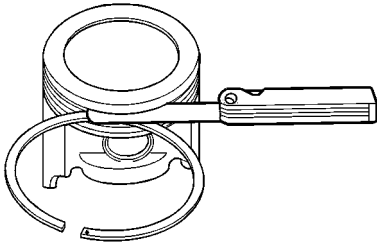

22934

11. To determine piston pin-to-bore clearance, use a micrometer and measure the piston pin.

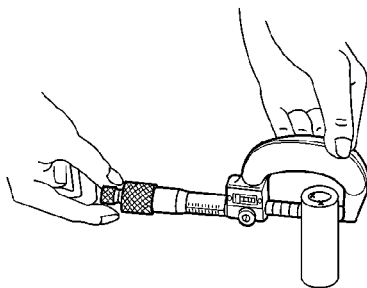

4976

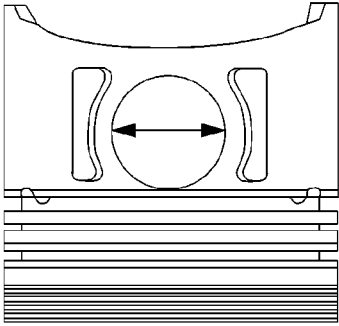

4975

12. To determine piston pin-to-bore clearance, use an inside micrometer and measure the piston pin bore.
13. To determine the piston pin-to-bore clearance, subtract the piston pin diameter from the piston pin bore diameter. Engine Specifications” on page 155

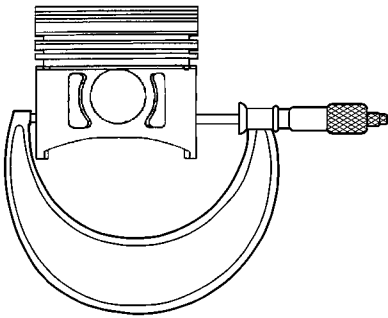

188016

14. Measure the piston with a micrometer at a right angle to the piston pin bore, measure the piston at 11 mm (0.433 in) from the bottom of the skirt. Engine Specifications” on page 155.
15. If the piston is not within specifications, replace the piston and pin as an assembly.

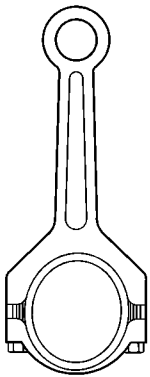

156167

16. Inspect the connecting rod for an out-of-round bearing bore. Engine Specifications” on page 155.

17. Inspect the connecting rod for twisting.
18. Inspect the connecting rod for damage to the bearing cap and bolt threads.

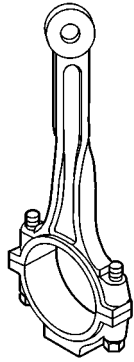

156169

19. Measure the piston compression ring end gap.

**Important: Fit each compression ring to the cylinder in which it will be used.**

20. Place the compression ring into the cylinder bore.
  - a. Push the compression ring into the cylinder bore to approximately 6.5 mm (0.25 in) above the ring travel. The ring must be square to the cylinder wall.
  - b. Use a feeler gauge in order to measure the end gap.
  - c. Select another size ring set if the end gap exceeds specifications. Engine Specifications” on page 155.

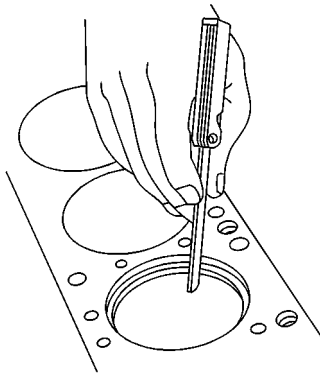

4968

### Piston Selection

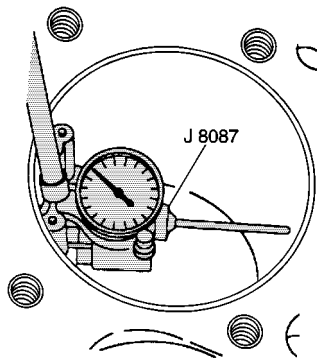

4972

### Tools Required

J 8087 Cylinder Bore Gauge

**Note! Measurements of all components should be taken with the components at normal room temperature.**

For proper piston fit, the engine block cylinder bores should not have excessive wear or taper.

A used piston and piston pin set may be reinstalled if, after cleaning and inspection, the piston and piston pin are within specifications.

1. Use the J 8087 in order to measure the cylinder bore diameter. Measure at a point 64 mm (2.5 in) from the top of the cylinder bore and 90 degrees to the crankshaft centerline.

2. Measure the J 8087 with a micrometer and record the reading.

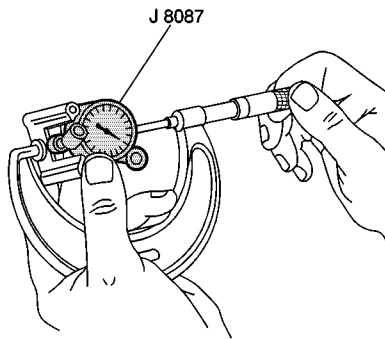

4974

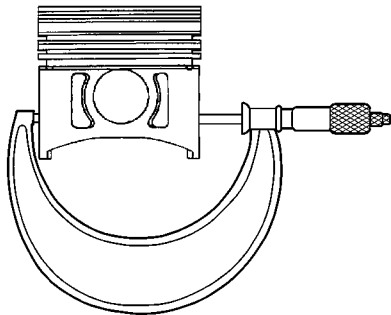

188016

3. With a micrometer or caliper at a right angle to the piston pin bore, measure the piston 11 mm (0.433 in) from the bottom of the skirt.
4. Subtract the piston diameter from the cylinder bore diameter in order to determine piston-to-bore clearance. Engine Specifications” on page 155.
5. If the proper clearance cannot be obtained, then select another piston and measure the clearances.
6. If the proper fit cannot be obtained, the cylinder bore may require honing or boring.
7. When the piston-to-cylinder bore clearance is within specifications, permanently mark the top of the piston for installation into the proper cylinder.

### Piston and Connecting Rod Assemble

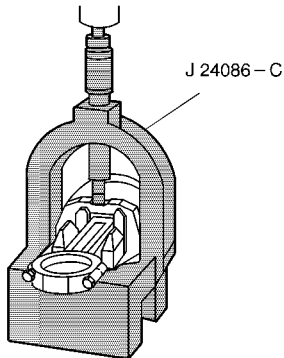

4965

#### Tools Required

J 24086-C Piston Pin Remover/Installer



**Warning!** Avoid contact with **HOT** components. Wear safety glasses and protective gloves to avoid personal injury.

**Note!** Applying excessive heat to the connecting rod may damage or distort the rod. Rod temperature **SHOULD NOT** exceed 315°C (600°F). At this temperature, the end of the connecting rod will turn a straw color upon visual inspection.

**Note!** After the J 24086-C installer hub bottoms on the support assembly, **DO NOT** exceed 35,000 kPa (5,000 psi) or the tool may be damaged.

**Note!** When assembling the piston and connecting rod, the mark on the top of the piston must point to the front of the engine block. The left bank connecting rods should have the flange face toward the front of the engine block. The right bank connecting rods should have the flange face toward the rear of the engine block.

The piston pin has an interference fit into the connecting rod and is full floating in the piston.

1. 1. Install the piston pin and connecting rod assembly.
  - a. Lubricate the piston pin bores with clean engine oil.
  - b. Use a torch and apply MILD heat to the piston pin end of the connecting rod.
  - c. Use the J 24086-C in order to press the piston pin into the piston and connecting rod assembly.
  - d. Inspect for the proper installation of the piston and piston pin. The piston must move freely on the piston pin with no binding or interference.

**Notice: Use a piston ring expander to install the piston rings. The rings may be damaged if expanded more than necessary.**

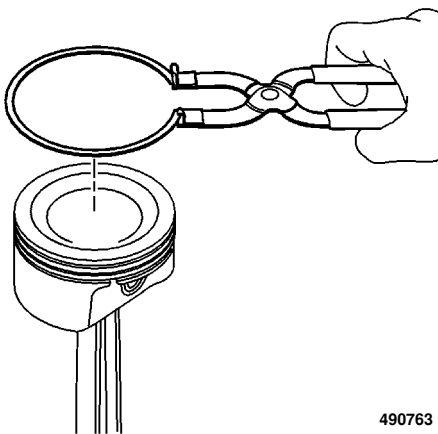

490763

2. 2. Install the piston rings onto the piston.
  - a. Install the oil control piston ring spacer.
  - b. Install the lower oil control piston ring.
  - c. Install the upper oil control piston ring.
  - d. Install the lower compression piston ring.
 

The mark on the side of the piston ring should face the top of the piston.
  - e. Install the upper compression piston ring.
 

The mark on the side of the piston ring should face the top of the piston.



4967

3. 3. Space the compression piston ring end gaps 120 degrees apart.
4. 4. Space the oil control piston ring end gaps a minimum of 90 degrees apart.

**Installation**

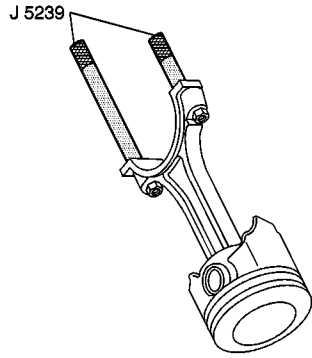

1. 1. Apply clean engine oil to the following components:
  - The piston
  - The piston rings
  - The cylinder bore
  - The bearing surfaces
2. Install the J 5239 onto the connecting rod bolts.

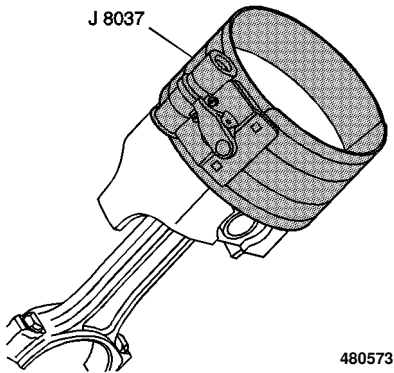

3. Install the J 8037 onto the piston and compress the piston rings.

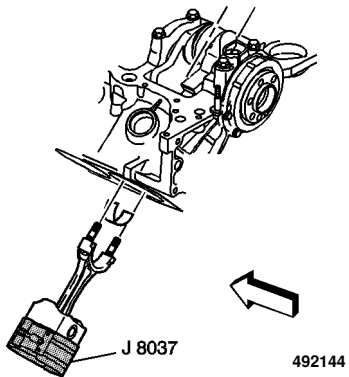

**Note! The mark on the top of the piston must face the front of the engine block.**

When assembled, the flanges on the connecting rod and connecting rod cap should face to the front of the engine block on the left bank, and to the rear of the engine block on the right bank.

4. Install the piston and connecting rod assembly, and the J 8037 into the proper cylinder bore.



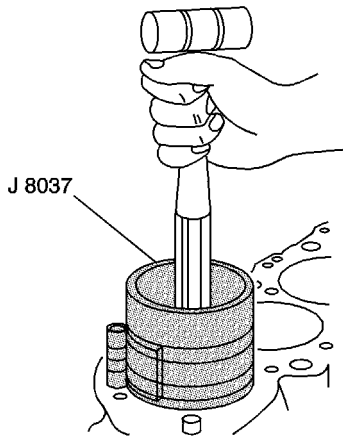

5159

5. Use the J 8037 and the J 5239 and lightly tap the top of the piston with a wooden hammer handle.
  - a. Hold the J 8037 firmly against the engine block until all of the piston rings have entered the cylinder bore.
  - b. Use the J 5239 in order to guide the connecting rod onto the crankshaft journal.

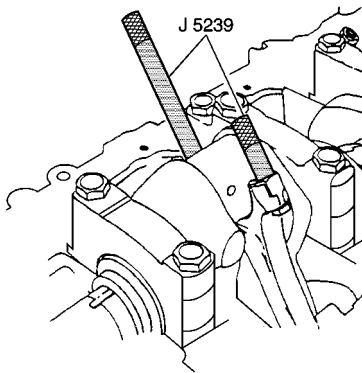

31373

6. Remove the J 5239.

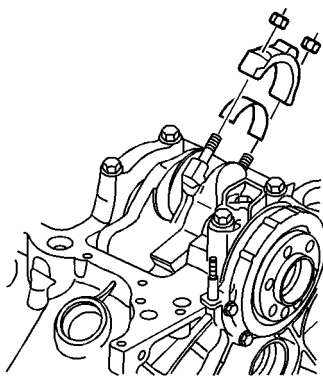

480549

7. Install the connecting rod caps, bearings and nuts.
  - a. Tighten the nuts evenly on the first pass to 27 N•m (20 ft. lb.).
  - b. Use the J 36660 in order to tighten the nuts on the final pass an additional 70 degrees.

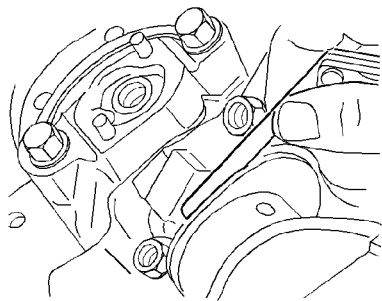

5163

8. After the piston and connecting rod assemblies have been installed, then lightly tap each connecting rod assembly (parallel to the crank pin) in order to ensure that the connecting rods have side clearance.
9. Use a feeler gauge or a dial indicator to measure the connecting rod side clearance between the connecting rod caps. The connecting rod side clearance should be 0.15-0.44 mm (0.006-0.017 in).
10. Install oil pan, Oil Pan and Oil Pump” on page 91
11. Install cylinder heads, Cylinder Head” on page 79.
12. Install engine in boat, Engine Specifications” on page 155

## Engine Coupler

### Removal

1. Remove engine from boat, Engine Specifications” on page 155.

**Note! If coupler is being replaced due to coupler failure (rubber hub of splined hub), check engine alignment after installing new coupler. Engine Specifications” on page 155.**

2. Cut tie strap holding flywheel housing drain hose (if equipped) to starter motor.
3. Take out screws holding flywheel housing cover, then slide out cover.

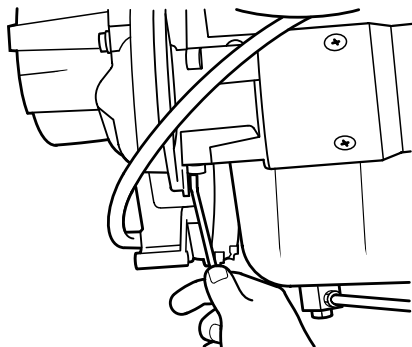

4. Remove nut, lock washer, and ground leads from ground stud and coil bracket. Remove inner nut, lock washer and washer.

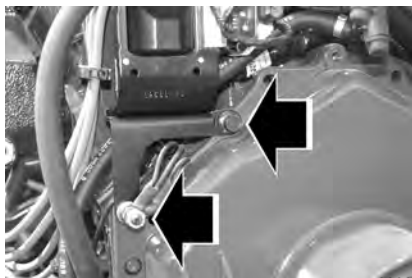

22927

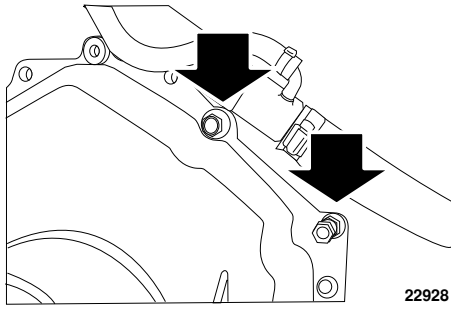

5. Remove nut, lock washer, and ground leads from ground stud and power steering cooler bolt.
6. Unscrew remaining flywheel housing bolts, lock washers and washers. Note position of clamps so they can be installed in original position.

7. Lift flywheel housing off engine block and set aside.

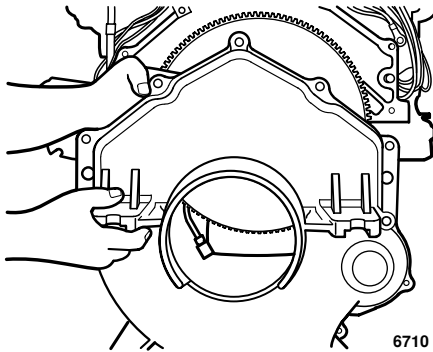

8. Unscrew six locknuts, then pull coupler off flywheel.

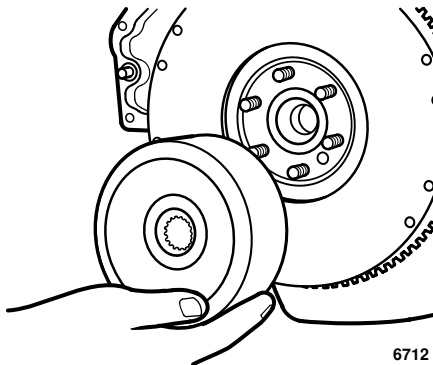

**Inspection**

Inspect the coupler for burnt rubber, chunks missing from the rubber or cracks in the aluminum. Check for melted rubber around outer diameter of aluminum. If any of these conditions are found, replace the coupler.

**Installation**

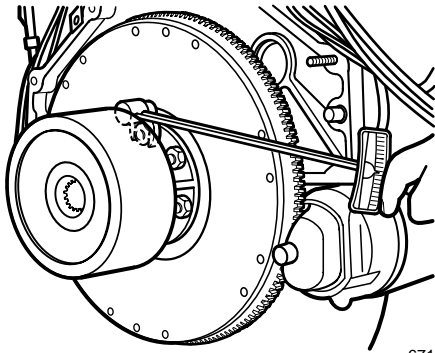

6714

1. Slide coupler onto crankshaft studs. Install new locknuts. Use a crowfoot wrench and tighten nuts to 40-45 ft. lb. (54-61 N•m).

**NOTE! Do not reuse coupler locknuts. Always install new locknuts.**

2. Tighten nuts in sequence.

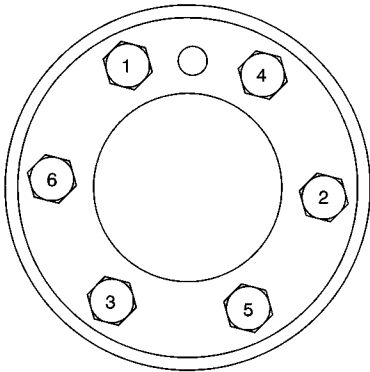

63174

3. Install flywheel housing. Place clamps in their original positions, and attach coil bracket and power steering cooler. Tighten screws to 38-49 N•m (28-36 ft. lb.)
4. Place washer, lock washer and nut on ground stud. Tighten inner nut to 47-54 N•m (35-40 ft. lb.) Attach electrical leads to ground stud. Install lock washer and tighten outer nut securely. Install ground stud hardware on opposite side of block.

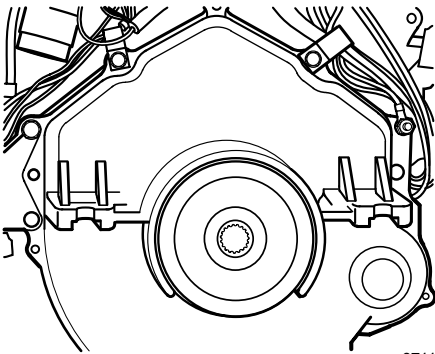

6711A

5. Slide flywheel cover up into place. Install screws and tighten them to 7-9 N•m (60-84 in. lb.)

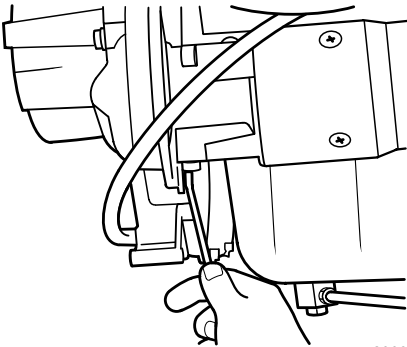

20034

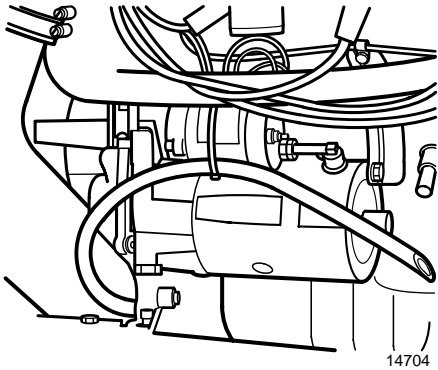

6. Attach flywheel housing drain hose (if equipped) to starter motor with tie strap.
7. Install engine, "Engine Specifications" on page 155.

## Flywheel

### Removal

1. Engine coupler, "Engine Coupler" on page 132
2. Remove flywheel from crankshaft studs.

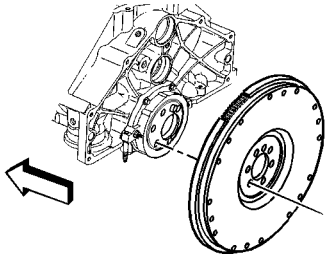

188129

**Note!** If replacing the engine flywheel, then **NEW** flywheel weights must be installed into the **NEW** engine flywheel in the same location as the old flywheel weights in the old engine flywheel.

3. Note the position of any flywheel weights for assembly (if applicable).

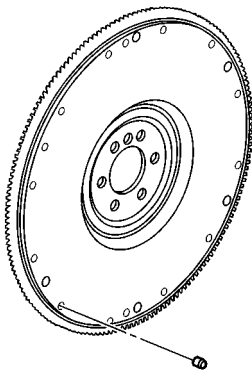

64126

**Inspection**

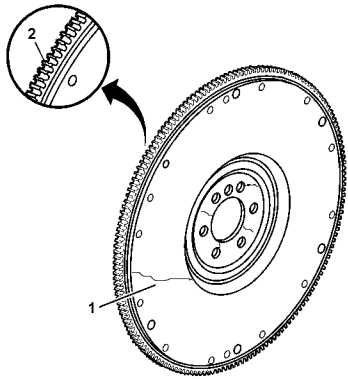

188086

4. Inspect the engine flywheel for the following:
  - Cracks other surface damage (1)
  - Damaged ring gear teeth (2)
  - Loose or improperly positioned ring gear
5. The ring gear has an interference fit onto the engine flywheel and the ring gear should be positioned completely flat against the flange of the engine flywheel.

**Installation**

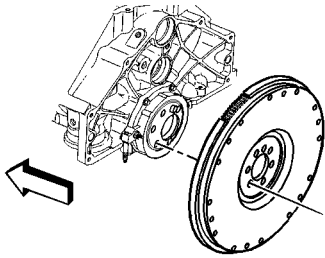

188129

6. Install flywheel on crankshaft studs.
7. Install engine coupler, Engine Coupler" on page 132.

## Crankshaft Rear Oil Seal and Housing

**Remove**

1. Remove engine from boat, See "Engine Specifications" on page 155..
2. Remove engine coupler, See "Engine Coupler" on page 132..
3. Remove flywheel, See "Engine Specifications" on page 155..
4. Remove the crankshaft rear oil seal from the crankshaft rear oil seal housing.

Insert a suitable tool into the access notches and then carefully pry the crankshaft rear oil seal from the crankshaft rear oil seal housing.

5. Discard the crankshaft rear oil seal.

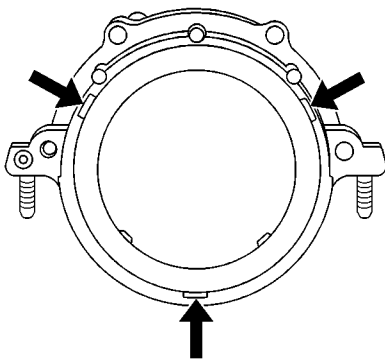

31379

If removing oil seal housing, remove oil pan. Oil Pan and Oil Pump” on page 91

6. Remove the crankshaft rear oil seal housing nut and bolts.
7. Remove the crankshaft rear oil seal housing.
8. Remove the crankshaft rear oil seal housing gasket.
9. Discard the crankshaft rear oil seal housing gasket.

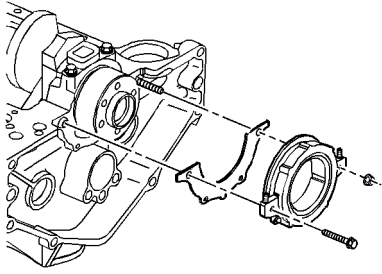

11479

10. If necessary, remove the S type pin.

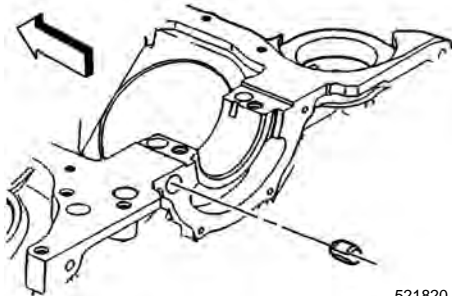

521820

**Installation**

**Tools Required**

J 35621-B Rear Main Seal Installer

1. Install the crankshaft rear oil seal housing retainer stud and tighten to 6 N•m (53 lb. in).

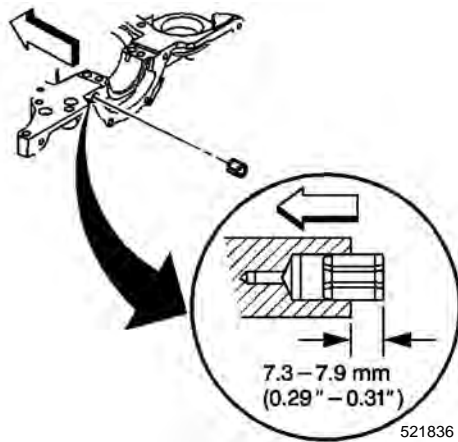

521836

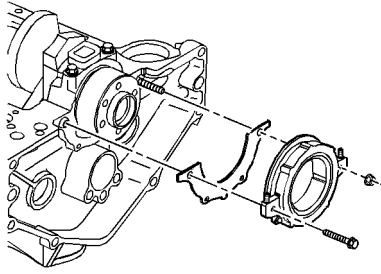

11479

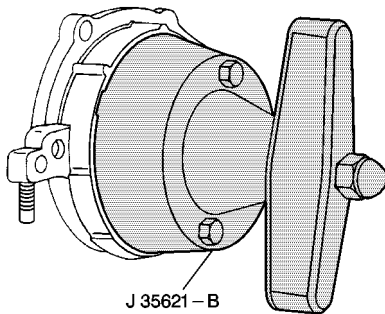

334550

**NOTE! Always use a NEW crankshaft rear oil seal housing gasket when installing the crankshaft rear oil seal housing.**

2. Install the NEW crankshaft rear oil seal housing gasket.
3. Install the crankshaft rear oil seal housing onto the crankshaft rear oil seal housing retainer stud.
4. Install the crankshaft rear oil seal housing nut and bolts. Tighten nut and bolts to 12 N•m (106 lb. in).

5. Apply a small amount (2 to 3 drops) of clean engine oil to the bore of the crankshaft rear oil seal housing.
6. Apply a small amount (2 to 3 drops) of clean engine oil to the outside diameter of the engine flywheel pilot flange.
7. Apply a small amount (1 drop) of clean engine oil to the outside diameter of the flywheel locator pin.
8. Apply a small amount (2 to 3 drops) of clean engine oil to the crankshaft seal surface.
9. Inspect the J 35621-B flange for imperfections that may damage the crankshaft rear oil seal.

Minor imperfections may be removed with a fine grade emery cloth.



**Caution!**

**DO NOT allow oil or any other lubricants to contact the seal lip of the crankshaft rear oil seal.**

10. Remove the sleeve from the crankshaft rear oil seal.
11. Apply a small amount (2 to 3 drops) of clean engine oil to the outside diameter of the crankshaft rear oil seal.
12. Install the crankshaft rear oil seal onto the J 35621-B.
13. Install the J 35621-B onto the rear of the crankshaft and hand tighten the tool bolts until snug.



**Caution! Proper alignment of the crankshaft rear oil seal is critical. Install the crankshaft rear oil seal near to flush and square to the crankshaft rear oil seal housing. Failing to do so may cause the crankshaft rear oil seal or the crankshaft rear oil seal installation tool to fail.**

14. Install the crankshaft rear oil seal onto the crankshaft and into the crankshaft rear oil seal housing.
  - a. Turn the J 35621-B wing nut clockwise until the crankshaft rear oil seal is installed near to flush and square to the crankshaft rear oil seal housing.



Increased resistance will be felt when the crankshaft rear oil seal has reached the bottom of the crankshaft rear oil seal housing bore.

- b. Turn the J 35621-B wing nut counterclockwise to release the J 35621-B from the crankshaft rear oil seal.
15. Remove the J 35621-B from the crankshaft.
16. Wipe off any excess engine oil with a clean rag.
17. Install oil pan if removed. See "Oil Pan and Oil Pump" on page 91..
18. Install flywheel. See "Flywheel" on page 135..
19. Install engine coupler. See "Engine Coupler" on page 132.
20. Install engine in boat. See "Engine Specifications" on page 155..

## Crankshaft

- Remove**
1. Remove engine from boat, See "Engine Removal" on page 213..
  2. Remove cylinder heads, See "Cylinder Head" on page 79.
  3. Remove oil pan, See "Oil Pan and Oil Pump" on page 91..
  4. Remove pistons and connecting rods, See "Camshaft Bearings" on page 117..
  5. Remove timing chain and sprocket, See "Timing Chain and Sprocket" on page 110.
  6. Remove starter, See "Starter" on page 57..
  7. Remove engine coupler, See "Engine Coupler" on page 132..
  8. Mark or identify the crankshaft bearing cap locations, direction and positions for assembly.
  9. Remove the crankshaft bearing cap bolts.
  10. Remove the crankshaft bearing caps.

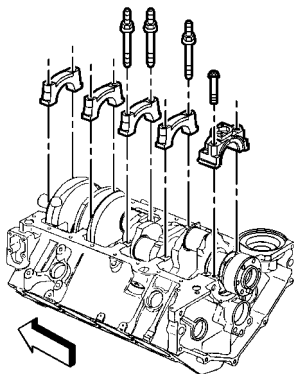

317268

11. Remove the crankshaft.

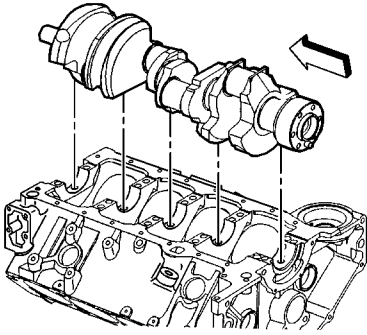

317351

12. Remove the crankshaft bearings from the crankshaft bearing caps.

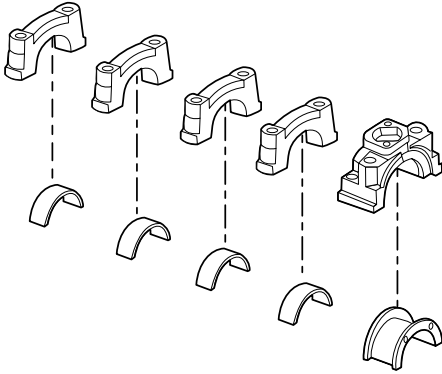

317295

13. Remove the crankshaft bearings from the engine block.

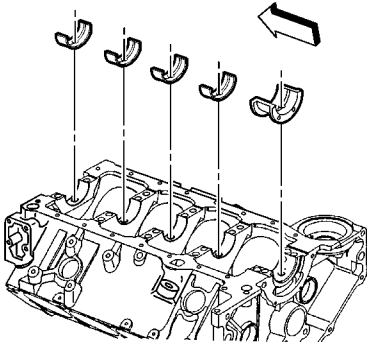

317292

### Crankshaft and Bearings Clean and Inspect

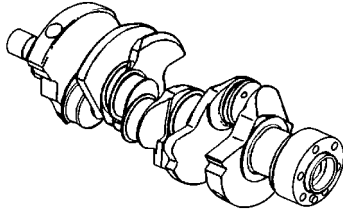

334383

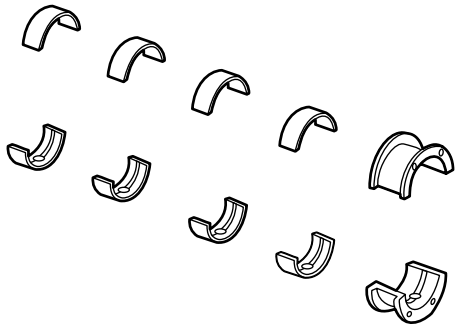

334386A

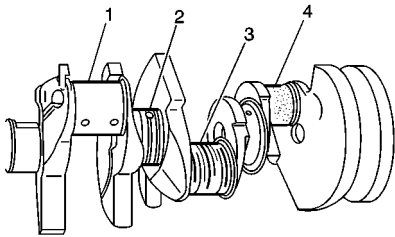

156170

#### Tools Required

J 7872 Magnetic Base Dial Indicator

J 36660 Electronic Torque Angle Meter



**Warning! Wear Safety Glasses.**



**Caution! Use care when handling the crankshaft. Avoid damage to the crankshaft bearing surfaces.**

1. Clean the crankshaft in cleaning solvent. Remove all sludge or restrictions from the oil passages.
2. Dry the crankshaft with compressed air.

3. Clean the crankshaft bearings in cleaning solvent. Wipe the crankshaft bearings clean with a soft cloth.



**Caution! Do not scratch the crankshaft bearing surface.**

4. Dry the crankshaft bearings with compressed air.

5. Inspect the crankshaft for the following:

- Crankshaft journals (1) should be smooth with no evidence of scoring or damage.
- Deep grooves (2)
- Scratches or uneven wear (3)
- Pitted surfaces (4)
- Wear or damage to the thrust journal surfaces
- Scoring or damage to the rear seal surface
- Restrictions to the oil passages
- Damage to the threaded bolt holes

6. Inspect the crankshaft balancer key (1), the keyway (2) and the threaded hole (3) for damage. Repair or replace the crankshaft as necessary.

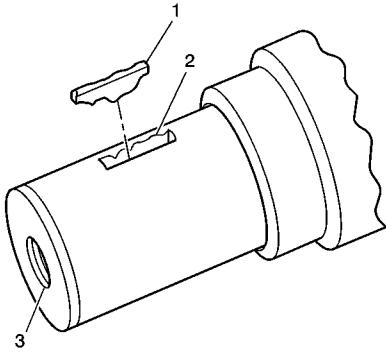

188090

7. Measure the crank pins for out-of-round and taper. Engine Specifications" on page 155.

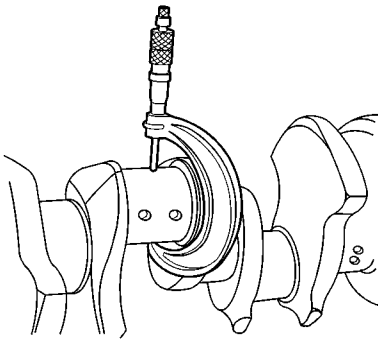

188015

8. Use a suitable support to support the crankshaft on the front and rear journals.
9. Use the J 7872 in order to measure the crankshaft journal run out. The crankshaft run out should not exceed 0.025 mm (0.0010 in).

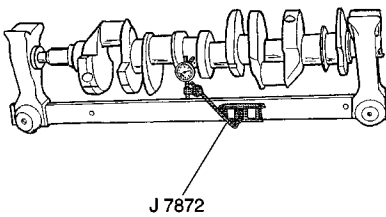

35210

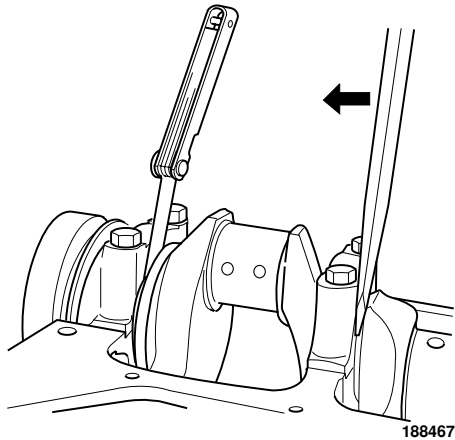

10. Measure the crankshaft end play.

**Note!** In order to properly measure the crankshaft end play, the crankshaft, the crankshaft bearings and the crankshaft bearing caps, the crankshaft bearing cap bolts must be installed into the engine block and the bolts tightened to specifications.

Firmly thrust the crankshaft first rearward, then forward. This will align the crankshaft rear bearings and the crankshaft thrust surfaces.

- a. With the crankshaft pushed forward, insert a feeler gauge between the crankshaft and the crankshaft bearing surface and then measure the clearance. Refer to Engine Mechanical Specifications.
- b. If the correct end play cannot be obtained, verify that the correct size crankshaft bearing has been installed. Engine Specifications” on page 155.
- c. Inspect the crankshaft for binding. Turn the crankshaft to check for binding. If the crankshaft does not turn freely, then loosen the crankshaft bearing cap bolts, one bearing cap at a time, until the tight crankshaft bearing is located.

Burrs on the crankshaft bearing cap, foreign matter between the crankshaft bearing and the engine block or crankshaft bearing cap or a faulty crankshaft bearing could cause a lack of clearance at the crankshaft bearing.

11. Inspect the crankshaft bearings for craters or pockets. Flattened sections on the crankshaft bearing halves also indicate fatigue.

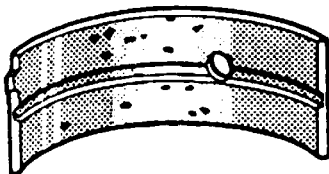

52051

12. Inspect the crankshaft bearings for excessive scoring or discoloration.

13. Inspect the crankshaft bearings for dirt or debris imbedded into the crankshaft bearing material.

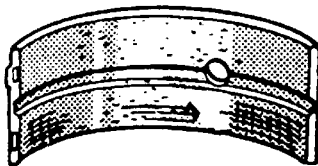

52053

14. Inspect the crankshaft bearings for improper seating indicated by bright, polished sections of the crankshaft bearings.

- If the lower half of the crankshaft bearing is worn or damaged, both the upper and lower halves of the crankshaft bearing should be replaced.
- Generally, if the lower half of the crankshaft bearing is suitable for use, the upper half of the crankshaft bearing should also be suitable for use.

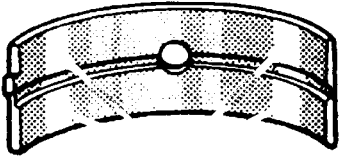

52056

### Measuring Crankshaft Bearing Clearances

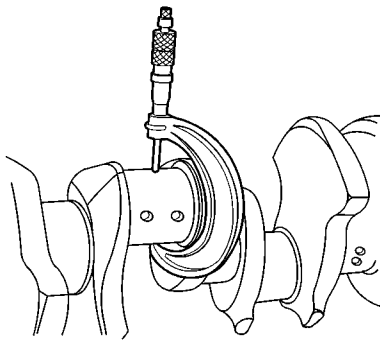

188015

- The crankshaft bearings are of the precision insert type and do not use shims for adjustment. If the clearances are excessive, then new upper and lower crankshaft bearings will be required. The service crankshaft bearings are available in the standard size and an undersize.
- The selective fitting of the crankshaft bearings are necessary in production in order to obtain close tolerances. For this reason, in one journal bore you may use one-half of a standard crankshaft bearing with one-half of an undersize crankshaft bearing
- In order to determine the correct replacement crankshaft bearing size, the crankshaft bearing clearance must be measured accurately. Either the micrometer or plastic gauge method may be used; however, the micrometer method gives more reliable results and is preferred. When checking connecting rod bearing clearances, the plastic gauge method will result in unreliable measurements. The use of J 43690 is preferred.
- Normally the crankshaft bearing journals wear evenly and are not out-of-round. However, if a crankshaft bearing is being fitted to an out-of-round crankshaft bearing journal, be sure to fit to the maximum diameter of the crankshaft bearing journal. If the crankshaft bearing is fitted to the minimum diameter and the crankshaft bearing journal will result in rapid crankshaft bearing failure.
- If the crankshaft bearing clearance is within specifications, the crankshaft bearing is satisfactory. If the clearance is not within specifications, replace the crankshaft bearing. Always replace both the upper and lower crankshaft bearings as a set.
- A standard or oversize crankshaft bearing combination may result in the proper clearance. If the proper crankshaft bearing clearance cannot be achieved using the standard or the undersize crankshaft bearings, it may be necessary to repair or replace the crankshaft.

### Micrometer Method for Crankshaft Bearings

1. Measure the crankshaft journal diameter with a micrometer in several places, approximately 90 degrees apart, and then average the measurements.

2. Determine the taper and the out-of-round of the crankshaft journal. Refer to "Crankshaft Journal Measurements" in "Engine Specifications" on page 155.
3. Install the crankshaft bearings into the engine block or connecting rod assembly.

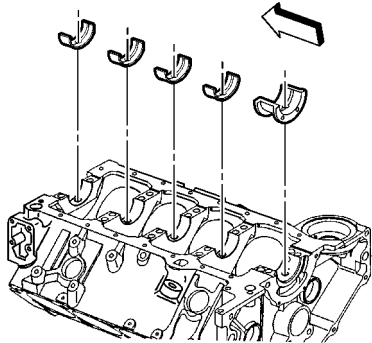

317292

4. Install the bearing cap bolts and tighten to specifications.
5. Measure the bearing inside diameter (ID) at two points 90 degrees apart. Average the measurements.
6. In order to determine the bearing clearance, subtract the average journal diameter from the average bearing inside diameter.
7. Compare the readings to specifications. Refer to Engine Mechanical Specifications.
8. Replace bearing halves as required to obtain the proper bearing clearances.

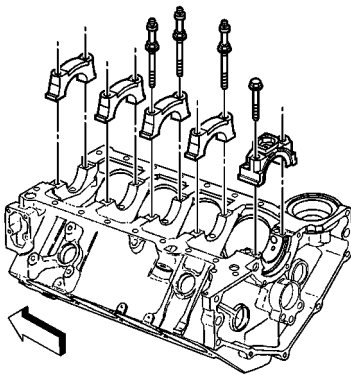

353070

**Measuring Crankshaft Bearing Clearances (Plastic Gauge Method)**

1. Install the crankshaft bearings into the engine block.
2. Install the crankshaft.

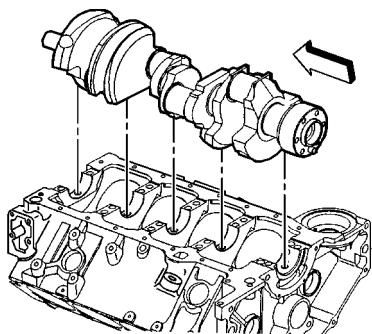

317351

3. Install the gauging plastic the full width of the journal.

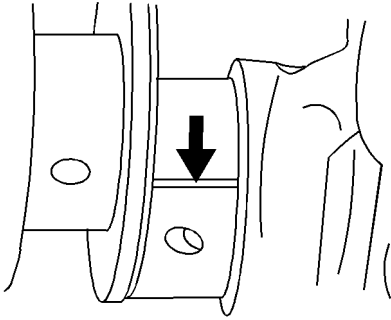

500655

4. Install the crankshaft bearings into the crankshaft bearing caps.

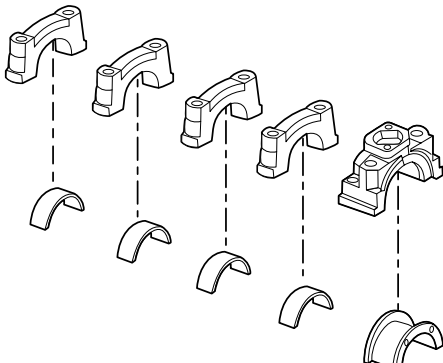

317295

5. Install the crankshaft bearing caps in the original positions and with the arrow on the crankshaft bearing caps in the direction of the front of the engine block.
6. Install the crankshaft bearing cap bolts.
  - a. Tighten the crankshaft bearing cap bolts on the first pass to 20 N•m (15 lb. ft.).
  - b. Tighten the crankshaft bearing cap bolts on the final pass an additional 73 degrees using the J 36660.
7. Remove the crankshaft bearing cap bolts.
8. Remove the crankshaft bearing caps. The gauging plastic may adhere to either the crankshaft-bearing journal or the crankshaft-bearing surface.

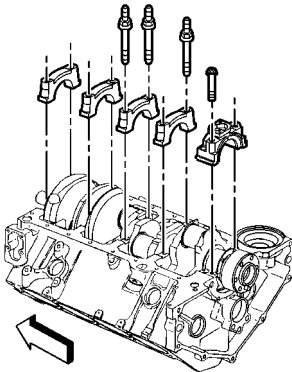

317268



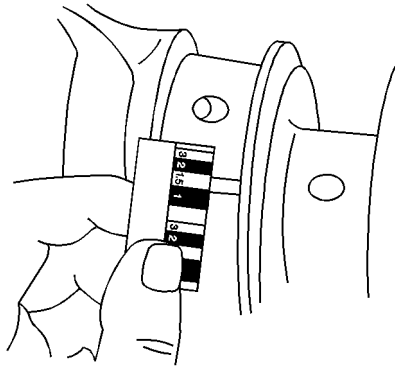

500656

9. Without removing the gauging plastic, measure the compressed width at the widest point using the graduated scale on the edge of the gauging plastic envelope.

If the flattened gauging plastic tapers toward the middle or the ends, there may be a difference in clearance indicating taper, low spot or other irregularity of the crankshaft bearing or the crankshaft-bearing journal.

10. Remove the flattened gauging plastic.
11. Measure the remaining crankshaft bearing journals.

### Crankshaft and Bearings Installation

#### Tools Required

J 36660 Electronic Torque Angle Meter

1. Install the crankshaft bearings into the engine block.
2. Apply clean engine oil to the crankshaft bearings.

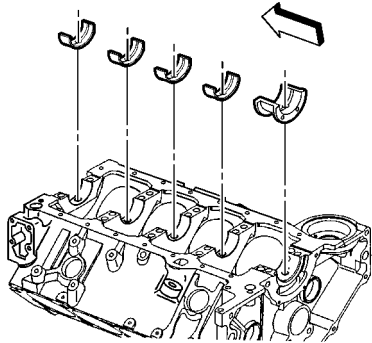

317292

3. Apply clean engine oil to the crankshaft bearing journals.
4. Install the crankshaft.

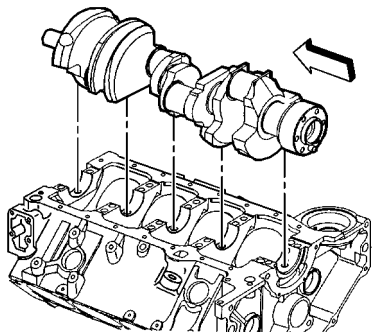

317351

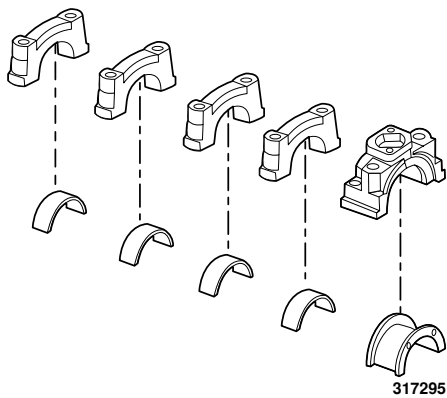

317295

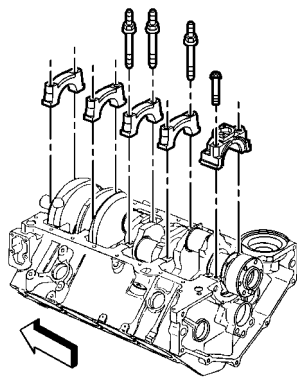

317268

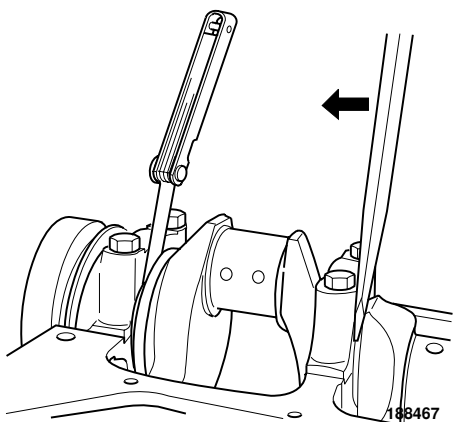

188467

5. Install the crankshaft bearings into the crankshaft bearing caps.
6. Apply clean engine oil to the crankshaft bearings.
7. Install the crankshaft bearing caps in the original position and with the arrow on the crankshaft bearing caps in the direction of the front of the engine block.
8. Install the crankshaft bearing cap bolts until snug.
9. Thrust the crankshaft rearward in order to set and align the crankshaft thrust bearings and the crankshaft bearing caps.
10. Thrust the crankshaft forward in order to align the rear faces of the crankshaft thrust bearings.
11. Tighten the crankshaft bearing cap bolts.
  - a. Tighten the crankshaft bearing cap bolts on the first pass to 20 N•m (15 lb. ft.).
  - b. Tighten the crankshaft bearing cap bolts on the final pass an additional 73 degrees using the J 36660.
12. Measure the crankshaft end play.
  - a. Firmly thrust the crankshaft rearward, and then forward.  
This will align the crankshaft rear bearing thrust surfaces.
13. With the crankshaft pushed forward, insert a feeler gauge between the crankshaft and the crankshaft rear bearing thrust surface to measure the clearance.
  - Crankshaft end play 0.05-0.20 mm (0.002-0.008 in)
14. Rotate the crankshaft in order to check for binding.
15. A bent crankshaft or lack of proper crankshaft bearing clearance may cause binding.
16. If the crankshaft does not turn freely, loosen the crankshaft bearing cap bolts on 1 crankshaft bearing cap at a time in order to determine the location of the binding.
17. A lack of proper crankshaft bearing clearance may be caused by the following:
  - Burrs on the crankshaft bearing cap
  - Foreign material between the crankshaft bearing and the engine block
  - Foreign material between the crankshaft bearing and the crankshaft bearing cap

- Damaged crankshaft bearing
- Improper size crankshaft bearing

18. Install pistons and connecting rods, See “Piston, Connecting Rod, and Bearings” on page 63.
19. Install cylinder heads, See “Cylinder Head” on page 19
20. Install intake manifold, Intake Manifold” on page 58
21. Install oil pan, See “Oil Pan and Oil Pump” on page 29.
22. Install timing chain and sprocket, See “Timing Chain and Sprocket” on page 50.
23. Install flywheel, Flywheel” on page 135
24. Install engine coupler, See “Engine Coupler” on page 74.
25. Install starter, See “Starter” on page 6.
26. Install engine in boat, See “Remove and Install Engine” on page 82.

## Recondition Engine Block

### Engine Block Plug

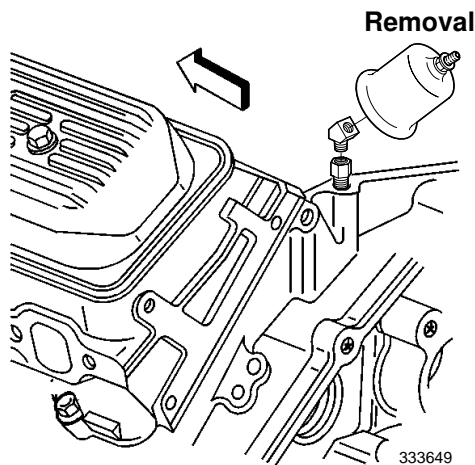

1. Remove the engine oil pressure sensor and fitting.

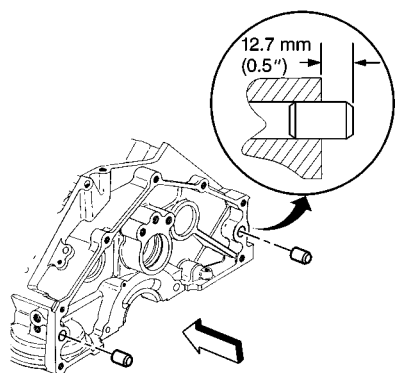

2. Remove the dowel straight pins (if required).

3. Remove the square socket plugs (engine block oil gallery) from the rear of the engine block.

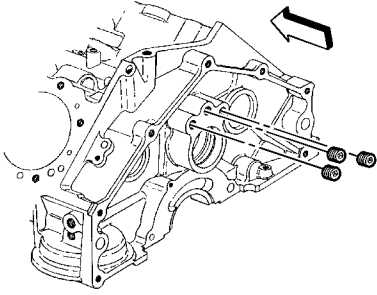

69847

4. Remove the left side rear and left rear top engine block oil gallery plugs.

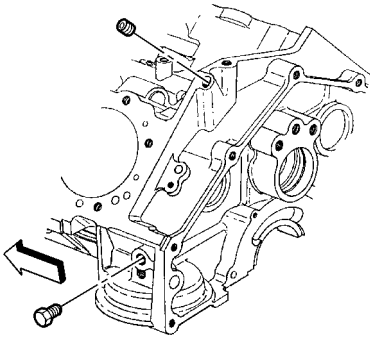

182841

5. Remove the expansion cup plug (camshaft rear bearing hole) and discard.

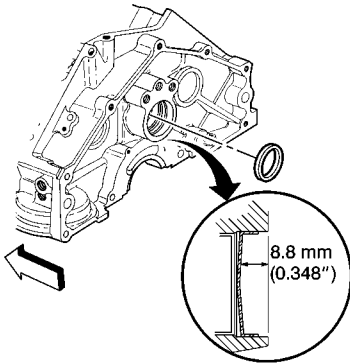

182854

6. Remove the engine block oil gallery plugs (front) from the engine block and discard.

Insert a 3/8 x 26 in. rod into the rear oil gallery holes in order to drive out the front engine block oil gallery plugs.

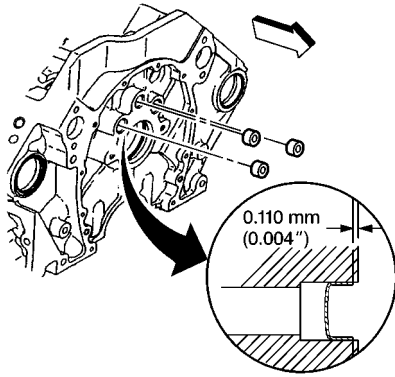

182838

7. Remove the spring type S pin (crankshaft rear oil seal housing locator) (if required).

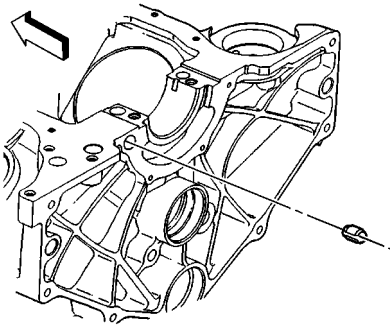

334323

8. Remove the engine block core hole plugs.
  - a. Use a suitable tool in order to drive the engine block core hole plugs into the coolant jacket.
  - b. Use a suitable tool in order to pull the engine block core hole plugs from the coolant jacket.
  - c. Discard the engine block core hole plugs.

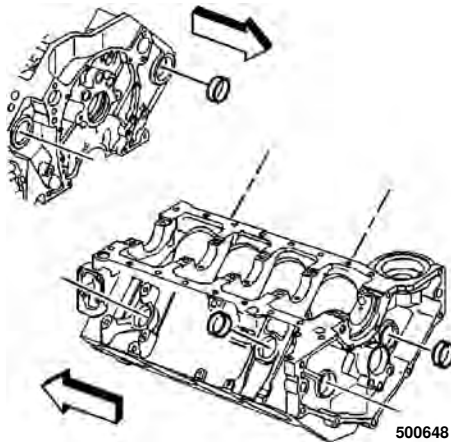

500648

## Engine Block Clean and inspect

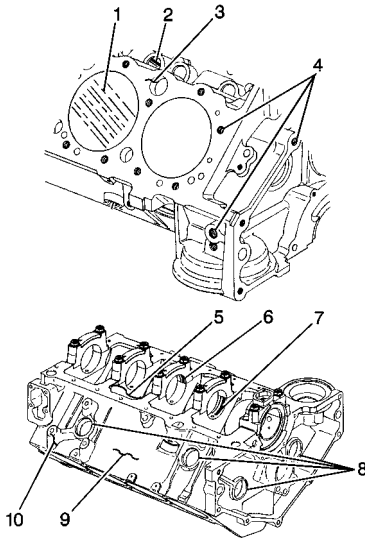

312797

### Tools Required

J 8087 Cylinder Bore Gauge



### **Warning! Wear Safety Glasses.**

1. Clean all the remaining sealing or gasket material from the sealing surfaces.
2. Clean the engine block with cleaning solvent.
3. Flush the engine block with clean water or steam.
4. Clean the cylinder bores.
5. Clean the oil galleries and the oil passages.
6. Clean the scale and the deposits from the coolant passages.



### **Caution! Clean all debris, dirt and coolant from the engine block cylinder head bolt holes. Failure to remove all foreign material may result in damaged threads, improperly tightened fasteners or damage to the components.**

7. Clean the engine block cylinder head bolt holes.
8. After cleaning the engine block, spray or wipe the cylinder bores and the machined surfaces with clean engine oil.
9. Inspect the following areas:
  - Coolant jackets (3) for cracks
  - Cylinder bores (1) for scratches or gouging
  - Valve lifter bores (2) for excessive scoring or wear
  - Threaded holes (4) for damage
  - Crankshaft bearing webs (5) for cracks
  - Crankshaft bearing caps (6) and the crankshaft bearing bores (7) for damage
    - The crankshaft bearing bores should be round and uniform when measuring the inside diameter (ID).
    - The surface where the crankshaft bearings contact the crankshaft bearing bore should be smooth.
    - If a crankshaft bearing cap is damaged and requires replacement, replace the crankshaft bearing cap first, then rebore the engine block crankshaft bearing bores and check for proper alignment. Finally, check the crankshaft for the proper clearances.
  - Engine block core hole plug bores (8) for damage
  - Engine block (9) for cracks or damage
  - Engine mount bosses (10) for damage

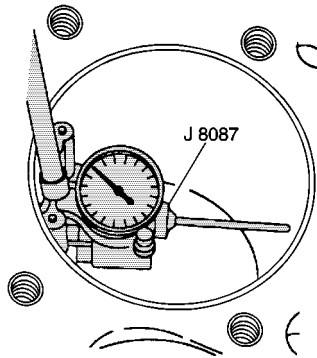

4972

## Cylinder Boring and Honing

### Honing Procedure

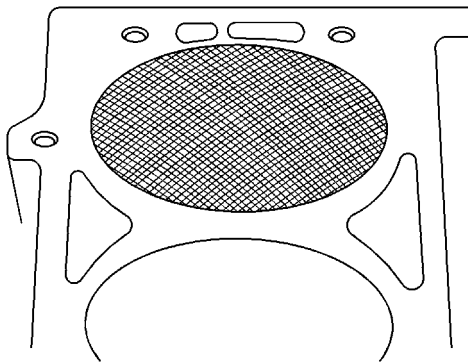

186747

10. Measure the cylinder bores for taper and out-of-round.
  - a. Depress the plunger on the J 8087 7 mm (0.275 in) or until the J 8087 enters the cylinder bore.
  - b. Center the J 8087 in the cylinder bore and turn the indicator dial to 0.
  - c. Move the J 8087 up and down the cylinder bore to determine the cylinder bore taper. See "Engine Specifications" on page 155.
  - d. Turn the J 8087 to different points around the cylinder bore to determine the cylinder bore out-of-round condition. Engine Specifications" on page 155



### Caution! Wear Safety Glasses.

1. When honing the cylinder bores, follow the manufacturer's recommendations for equipment use, cleaning and lubrication.
  - Use only clean sharp stones of the proper grade for the amount of material to be removed.
  - Dull, dirty stones cut unevenly and generate excessive heat.
  - DO NOT hone to a final grade with a coarse or medium-grade stone.
  - Leave sufficient metal so that all the stone marks will be removed with the fine grade stones.
  - Perform the final honing with a fine-grade stone and hone the cylinder bore in a crosshatch pattern at 45-65 degrees to obtain the proper clearance.
2. During the honing operation, thoroughly check the cylinder bore.
  - Repeatedly check the cylinder bore fit with the selected piston.
  - All measurements of the piston or cylinder bore should be made with the components at normal room temperature.
3. When honing to eliminate taper in the cylinder bore, use full strokes the complete length of the cylinder bore.
4. Repeatedly check the measurement at the top, the middle and the bottom of the cylinder bore.
  - The finish marks should be clean but not sharp.
  - The finish marks should be free from imbedded particles or torn or folded material.
5. By measuring the selected piston at the sizing point and then by adding the average of the clearance specification, the final cylinder bore honing dimension required can be determined.
6. When finished, the reconditioned cylinder bores should have less than or meet the specified out-of-round and taper requirements.
7. After the final honing and before the piston is checked for fit, clean the cylinder bore with hot water and detergent.
  - a. Scrub the cylinder bores with a stiff bristle brush.

- b. Rinse the cylinder bores thoroughly with clean hot water.
- c. Dry the cylinder bores with a clean rag.
- d. Do not allow any abrasive material to remain in the cylinder bores.
  - Abrasive material may cause premature wear of the new piston rings and the cylinder bores.
  - Abrasive material will contaminate the engine oil and may cause premature wear of the bearings.
8. Perform final measurements of the piston and the cylinder bore.
9. Permanently mark the top of the piston for the specified cylinder to which it has been fitted.
10. Apply clean engine oil to each cylinder bore in order to prevent rusting.

### Boring Procedure

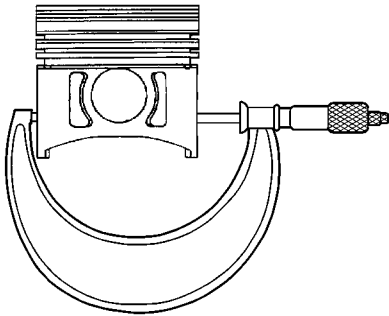

188016

### **Warning! Wear Safety Glasses.**

1. Before starting the honing or boring operation, measure all the new pistons with the micrometer contacting at points exactly 90 degrees from the piston pin centerline.
2. Thoroughly clean the top of the cylinder block in order to remove any dirt or burrs before using any type of boring bar.
3. Follow the instructions furnished by the manufacturer regarding the use of the boring equipment.
4. When boring the cylinders, make sure all the crankshaft bearing caps are installed in the original position and direction.
5. Tighten the crankshaft bearing caps to the proper torque specifications in order to avoid distortion of the cylinder bores in the final assembly.
6. When making the final cut with the boring bar, leave 0.03 mm (0.001 in) on the cylinder bore diameter for finish honing. This gives the required position to the cylinder clearance specifications. (Carefully perform the honing and boring operation in order to maintain the specified clearances between the pistons, the piston rings and the cylinder bores).



## Engine Specifications

**Table 1: Fastener Tightening Specifications**

| Application   | Metric (N·m) | English       |
|---|--------------|---------------|
| Camshaft Retainer Bolt                                | 12           | 106 in. lb.   |
| Camshaft Sprocket Bolt                                | 25           | 18 ft. lb.    |
| <b>Connecting Rod Nut</b>                             |              |               |
| First Pass  | 27           | 20 ft. lb.    |
| Final Pass  | 55 Degrees   |               |
| Crankshaft Balancer Bolt                              | 95           | 70 ft. lb.    |
| <b>Crankshaft Bearing Cap Bolt (Preferred Method)</b> |              |               |
| First Pass  | 20           | 15 ft. lb.    |
| Final Pass  | 73 Degrees   |               |
| Crankshaft Bearing Cap Bolt                           | 105          | 77 ft. lb.    |
| Crankshaft Position Sensor Bolt                       | 9            | 80 in. lb.    |
| Crankshaft Oil Deflector Nut                          | 40           | 30ft. lb.     |
| Crankshaft Pulley Bolt                                | 58           | 43 ft. lb.    |
| Crankshaft Rear Oil Seal Housing Bolt and Nut         | 12           | 106 in. lb.   |
| Crankshaft Rear Oil Seal Housing Retainer Stud        | 6            | 53 in. lb.    |
| <b>Cylinder Head Bolt (Preferred Method)</b>          |              |               |
| All Bolts First Pass in Sequence                      | 30           | 22 ft. lb.    |
| Long Bolts Final Pass in Sequence                     | 75 Degrees   |               |
| Medium Bolts Final Pass in Sequence                   | 65 Degrees   |               |
| Short Bolts Final Pass in Sequence                    | 55 Degrees   |               |
| Cylinder Head Core Hole Plug                          | 20           | 15 ft. lb.    |
| Distributor Cap Bolt                                  | 2.4          | 21 in. lb.    |
| Distributor Clamp Bolt                                | 25           | 18 ft. lb.    |
| Drive Belt Tensioner Bolt                             | 50           | 37 ft. lb.    |
| Engine Block Left Side Oil Galley Plug                | 20           | 15 ft. lb.    |
| Engine Block Left Rear Oil Galley Plug                | 30           | 22 ft. lb.    |
| Engine Block Right Rear Oil Galley Plug               | 20           | 15 ft. lb.    |
| Engine Block Coolant Drain Plug                       | 20           | 15 ft. lb.    |
| Engine Block Oil Galley Plug                          | 20           | 15 ft. lb.    |
| Engine Coolant Temperature Sensor                     | 20           | 15 ft. lb.    |
| Engine Flywheel and Coupler Nut                       | 54 - 61      | 40-45 ft. lb. |
| Engine Front Cover Bolt                               | 12           | 106 in. lb.   |

**Table 1: Fastener Tightening Specifications**

| <b>Application</b>  | <b>Metric (N•m)</b> | <b>English</b>  |
|---|---------------------|-----------------|
| Engine Mount Bracket Bolt to Engine                       | 34-39               | 25-29 ft. lb.   |
| <b>Engine Mount Flexible to Engine Mount Bracket</b>      |                     |                 |
| Top Nut   | 136-163             | 100-120 ft. lb. |
| Middle Nut  | 54-68               | 40-50 ft. lb.   |
| Bottom Nut  | 81-102              | 60-75 ft. lb.   |
| Engine Oil Pressure Gauge Sensor                          | 30                  | 22 ft. lb.      |
| Engine Oil Pressure Gauge Sensor Fitting (angle)          | 15                  | 11 ft. lb.      |
| Engine Oil Pressure Warning Switch Fitting                | 19                  | 14 ft. lb.      |
| Engine Oil Pressure Warning Switch                        | 16                  | 12 ft. lb.      |
| <b>Exhaust Manifold Bolt to Engine</b>                    |                     |                 |
| First Pass  | 15                  | 11 ft. lb.      |
| Final Pass  | 30                  | 22 ft. lb.      |
| <b>Exhaust Riser Bolt to Exhaust Manifold</b>             |                     |                 |
| First Pass  | 15                  | 11 ft. lb.      |
| Final Pass  | 36                  | 27 ft. lb.      |
| Circulating Water Pump Pulley                             | 32                  | 24 ft. lb.      |
| Generator and Drive Belt Tensioner Bracket Bolt to Engine | 36                  | 27 ft. lb.      |
| Generator and Drive Belt Tensioner Bracket Stud Nut       | 32                  | 24 ft. lb.      |
| Ground Wire Nut on Flywheel housing                       | 8                   | 6 ft. lb.       |
| Ignition Coil Bolt to Mounting Bracket                    | 8                   | 6 ft. lb.       |
| Ignition Coil Mounting Bracket Bolt to Flywheel Housing   | 31                  | 23 ft. lb.      |
| Knock Sensor  | 20                  | 15 ft. lb.      |
| <b>Lower Intake Manifold</b>                              |                     |                 |
| First Pass  | 3                   | 27 in. lb.      |
| Second Pass   | 12                  | 106 in. lb.     |
| Final Pass  | 15                  | 11 ft. lb.      |
| Oil Filter Adapter Bolt (GL models)                       | 25                  | 18 ft. lb.      |
| Oil Filter Fitting (GL models)                            | 35                  | 26 ft. lb.      |
| Oil Filter Adapter Fitting Bolt (GX <sub>i</sub> models)  | 35-40               | 26-30 ft. lb.   |
| Oil Pan Baffle Bolt                                       | 12                  | 106 in. lb.     |
| Oil Pan Stud  | 6                   | 53 in. lb.      |
| Oil Pan Stud Nut  | 25                  | 18 ft. lb.      |
| Oil Pan Bolt or Stud                                      | 12                  | 106 in. lb.     |
| Oil Pan Dipstick Adapter (Drain Hole)                     | 50                  | 37 ft. lb.      |

**Table 1: Fastener Tightening Specifications**

| Application                                  | Metric (N·m) | English     |
|--|--------------|-------------|
| Oil Pump Bolt to Rear Crankshaft Bearing Cap | 90           | 66 ft. lb.  |
| Oil Pump Cover Bolt                          | 12           | 106 in. lb. |
| Power Steering Pump Bolt                     | 50           | 37 ft. lb.  |
| Spark Plug                                   |              |             |
| Initial Installation (NEW Cylinder Head)     | 30           | 22 ft. lb.  |
| All Subsequent Installations                 | 15           | 11 ft. lb.  |
| Throttle Body Stud                           | 9            | 80 in. lb.  |
| Upper Intake Manifold Stud                   |              |             |
| First Pass                                   | 5            | 44 in. lb.  |
| Final Pass                                   | 9            | 80 in. lb.  |
| Valve Lifter Pushrod Guide Bolt              | 16           | 12 ft. lb.  |
| Valve Rocker Arm Bolt                        | 30           | 22 ft. lb.  |
| Valve Rocker Arm Cover Bolt                  | 12           | 106 in. lb. |
| Water Pump Bolt                              | 45           | 33 ft. lb.  |

**Table 2: Engine Mechanical Specifications**

| Application  | Metric  | English   |
|--|---|---|
| <b>General Data</b>                                    |   |   |
| Engine Type  | V-8   |   |
| Displacement   | 5.7 L   | 350 CID   |
| Bore   | 101.63 mm   | 4.0012 in.  |
| Stroke   | 88.39   | 3.480   |
| Compression Ratio                                      | 9.4:1   |   |
| Firing Order   | 1-8-4-3-6-5-7-2   |   |
| Spark Plug Gap   | 1.52 mm   | 0.060 in.   |
| Oil Pressure (Minimum) at Normal Operating Temperature | 42 kPa @ 1,000 r/m<br>125 kPa @ 2,000 r/m<br>166 kPa at 4,000 r/m | 6.0 psi @ 1,000 r/m<br>18.0 psi @ 2,000 r/m<br>24.0 psi @ 4,000 r/m |
| <b>Camshaft</b>  |   |   |
| End Play   | 0.05-0.30 mm  | 0.002-0.012 in  |
| Journal Diameter                                       | 47.440-47.490 mm  | 1.8677-1.8696 in  |
| Journal Diameter Out-of-Round (maximum)                | 0.025 mm  | 0.0010 in   |
| Lobe Lift (Exhaust)                                    | 7.20-7.30 mm  | 0.283-0.287 in  |
| Lobe Lift (Intake)                                     | 6.97-7.07 mm  | 0.274-0.278 in  |
| Runout (maximum)                                       | 0.065 mm  | 0.0026 in   |

**Table 2: Engine Mechanical Specifications**

| <b>Application</b>  | <b>Metric</b>      | <b>English</b>     |
|---|--------------------|--------------------|
| <b>Connecting Rod</b>   |                    |                    |
| Connecting Rod Bearing Clearance (Production)                   | 0.033-0.078 mm     | 0.0015-0.0031 in   |
| Connecting Rod Bearing Clearance (Service)                      | 0.025-0.063 mm     | 0.0010-0.0025 in   |
| Connecting Rod Side Clearance                                   | 0.15-0.68 mm       | 0.006-0.027 in     |
| Connecting Rod Journal Diameter                                 | 53.304-53.334 mm   | 2.0986-2.0998 in   |
| Connecting Rod Journal Taper (Production)                       | 0.007 mm (Max)     | 0.00030 in (Max)   |
| Connecting Rod Journal Taper (Service)                          | 0.025 mm (Max)     | 0.0010 in (Max)    |
| Connecting Rod Journal Out-of-Round (Production)                | 0.007 mm (Max)     | 0.0003 in (Max)    |
| Connecting Rod Journal Out-of-Round (Service)                   | 0.025 mm (Max)     | 0.0010 in (Max)    |
| <b>Crankshaft</b>   |                    |                    |
| Crankshaft Bearing Clearance (Journal #1-Production)            | 0.018-0.053 mm     | 0.0007-0.0021 in   |
| Crankshaft Bearing Clearance (Journal #2, #3 and #4-Production) | 0.030-0.068 mm     | 0.0012-0.0027 in   |
| Crankshaft Bearing Clearance (Journal #5-Production)            | 0.020-0.060 mm     | 0.0008-0.0024 in   |
| Crankshaft Bearing Clearance (Journal #1-Service)               | 0.025-0.051 mm     | 0.0010-0.0020 in   |
| Crankshaft Bearing Clearance (Journal #2, #3 and #4-Service)    | 0.025-0.064 mm     | 0.0010-0.025 in    |
| Crankshaft Bearing Clearance (Journal #5-Service)               | 0.038-0.063 mm     | 0.0015-0.0025 in   |
| Crankshaft End Play   | 0.050-0.20 mm      | 0.002-0.008 in     |
| Crankshaft Journal Diameter (Journal #1)                        | 62.189-62.212 mm   | 2.4484-2.4493 in   |
| Crankshaft Journal Diameter (Journal #2, #3 and #4)             | 62.181-62.207 mm   | 2.4481-2.4491 in   |
| Crankshaft Journal Diameter (Journal #5)                        | 62.185-62.207 mm   | 2.4482-2.4491 in   |
| Crankshaft Journal Out-of-Round (Production)                    | 0.005 mm (Max)     | 0.0002 in (Max)    |
| Crankshaft Journal Out-of-Round (Service)                       | 0.025 mm (Max)     | 0.0010 in (Max)    |
| Crankshaft Journal Taper (Production)                           | 0.005 mm (Max)     | 0.0002 in (Max)    |
| Crankshaft Journal Taper (Service)                              | 0.025 mm (Max)     | 0.0010 in (Max)    |
| Crankshaft Runout at Rear Flange                                | 0.025mm (Max)      | 0.0010 in (Max)    |
| <b>Cylinder Bore</b>  |                    |                    |
| Diameter  | 101.618-101.643 mm | 4.0007-4.0017 in   |
| Out-of-Round (Production)                                       | 0.025 mm (Max)     | 0.0010 in (Max)    |
| Out-of-Round (Service)  | 0.05 mm (Maximum)  | 0.002 in (Maximum) |
| Taper (Production-Relief Side)                                  | 0.025 mm (Max)     | 0.0010 in (Max)    |
| Taper (Production-Thrust Side)                                  | 0.012 mm (Max)     | 0.0005 in (Max)    |
| Taper (Service Limit)   | 0.025 mm (Max)     | 0.0010 in (Max)    |
| <b>Cylinder Head</b>  |                    |                    |

Table 2: Engine Mechanical Specifications

| Application   | Metric   | English                            |
|---|--|------------------------------------|
| Surface Flatness (Engine Block Deck)                    | 0.10 mm (Max)  | 0.004 in (Max)                     |
| Surface Flatness (Exhaust Manifold Deck)                | 0.05 mm (Max)  | 0.004 in (Max)                     |
| Surface Flatness (Intake Manifold Deck)                 | 0.10 mm (Max)  | 0.004 in (Max)                     |
| <b>Exhaust Manifold</b>                                 |  |                                    |
| Surface Flatness (Flange to Flange)                     | 0.25 mm (Max)  | 0.010 in (Max)                     |
| Surface Flatness (Individual Flange)                    | 0.05 mm (Max)  | 0.002 in (Max)                     |
| <b>Intake Manifold</b>                                  |  |                                    |
| Surface Flatness  | 0.10 mm (Max)  | 0.004 in (Max)                     |
| <b>Piston</b>   |  |                                    |
| Piston Bore Clearance (Production)                      | 0.018-0.053 mm   | 0.0007-0.002 in                    |
| Piston Bore Clearance (Service)                         | 0.018-0.053 mm   | 0.0007-0.002 in                    |
| <b>Piston Pin</b>                                       |  |                                    |
| Clearance in Piston (Production)                        | 0.013-0.023 mm   | 0.0005-0.0009 in                   |
| Clearance in Piston (Service)                           | 0.013-0.023 mm   | 0.0005-0.0009 in                   |
| Diameter  | 23.545-23.548 mm   | 0.9270-0.9271 in                   |
| Fit in Connecting Rod                                   | 0.021-0.040 mm<br>(Interference)   | 0.0008-0.0016 in<br>(Interference) |
| <b>Piston Rings (End Gap Measured in Cylinder Bore)</b> |  |                                    |
| Piston Compression Ring Gap (Top Groove)                | 0.25-0.40 mm   | 0.010-0.016 in                     |
| Piston Compression Ring Gap (2nd Groove)                | 0.46-0.66 mm   | 0.018-0.026 in                     |
| Piston Compression Ring Groove Clearance (Top Groove)   | 0.030-0.070 mm   | 0.0012-0.0027 in                   |
| Piston Compression Ring Groove Clearance (2nd Groove)   | 0.040-0.080 mm   | 0.0015-0.0031 in                   |
| Piston Oil Ring Gap (Production)                        | 0.25-0.76 mm   | 0.010-0.029 in                     |
| Piston Oil Ring Gap (Service)                           | 0.25-0.90mm  | 0.010-0.035 in                     |
| Piston Oil Ring Groove Clearance (Production)           | 0.046-0.096 mm   | 0.0018-0.0037 in                   |
| Piston Oil Ring Groove Clearance (Service)              | 0.046-0.100 mm   | 0.0018-0.0039 in                   |
| <b>Valve System</b>                                     |  |                                    |
| Valve Face Angle  | 45 Degrees   |                                    |
| Valve Head Edge Margin                                  | 0.79 mm (Minimum)  | 0.031 in (Minimum)                 |
| Valve Lash  | Rotate the Valve Rocker Arm Nut Clockwise 360°<br>(1 turn) from Zero Lash. |                                    |
| Valve Lifter  | Hydraulic Roller Type  |                                    |
| Valve Rocker Arm  | Roller Pivot Type  |                                    |
| Valve Rocker Arm Ratio                                  | 1.5:1  |                                    |

**Table 2: Engine Mechanical Specifications**

| Application   | Metric               | English                |
|---|----------------------|------------------------|
| Valve Seat Angle  | 46 Degrees           |                        |
| Valve Seat Runout   | 0.05 mm (Max)        | 0.002 in (Max)         |
| Valve Seat Width (Exhaust)  | 1.50-2.56 mm         | 0.059-0.101 in         |
| Valve Seat Width (Intake)   | 1.02-1.65 mm         | 0.040-0.065 in         |
| Valve Spring Free Length  | 51.3 mm              | 2.02 in                |
| Valve Spring Installed Height (Exhaust)   | 42.92-43.43 mm       | 1.670-1.700 in         |
| Valve Spring Installed Height (Intake)  | 42.92-43.43 mm       | 1.670-1.700 in         |
| Valve Spring Pressure (Closed)  | 338-374 N at 43.2 mm | 76-84 lb. at 1.70 in   |
| Valve Spring Pressure (Open)  | 832-903 N at 32.3 mm | 187-203 lb. at 1.27 in |
| Valve Stem Clearance (Exhaust-Production)   | 0.025-0.069 mm       | 0.0010-0.0027 in       |
| Valve Stem Clearance (Intake-Production)  | 0.025-0.069 mm       | 0.0010-0.0027 in       |
| Valve Stem Clearance (Exhaust-Service)  | 0.025-0.094 mm       | 0.0010-0.0037 in       |
| Valve Stem Clearance (Intake-Service)   | 0.025-0.094 mm       | 0.0010-0.0037 in       |
| Valve Stem Oil Seal Installed Height (Measured from the Top of the Large Diameter Valve Guide Bevel to the Bottom of the Valve Stem Oil Seal) | 1-2 mm               | 0.03937-0.07874 in     |

**Table 3: Sealants, Adhesives and Lubricants**

| Application   | Type of Material | Part No.            |
|---|------------------|---------------------|
| Camshaft Retainer Bolt  | Threadlock       | 1161053             |
| Crankshaft Balancer Keyway  | Adhesive         | 1161277             |
| Cylinder Head Bolt  | Sealant          | 1141570             |
| Engine Block to the Crankshaft Rear Oil Seal Housing Junction at the Oil Pan Sealing Surfaces | Adhesive         | 1161277             |
| Engine Block to the Engine Front Cover Junction at the Oil Pan Sealing Surfaces               | Adhesive         | 1161277             |
| Engine Block at the Lower Intake Manifold Sealing Surfaces                                    | Adhesive         | 1161277             |
| Engine Block Core Hole Plug   | Threadlock       | 1161053             |
| Engine Block Oil Gallery Plug   | Sealant          | 1141570             |
| Engine Coolant Temperature (ECT) Sensor   | Sealant          | 1141570             |
| Engine Coolant Temperature (ECT) Gauge Sensor   | Sealant          | 1141570             |
| Engine Oil Pressure Sensor  | Sealant          | 1141570             |
| Engine Oil Pressure Sensor Fitting  | Sealant          | 1141570             |
| Engine Oil Supplement   | Lubricant        | 1052367 GM Part No. |
| Exhaust Manifold Bolt/Stud  | Threadlock       | 1161053             |
| Expansion Cup Plug (Camshaft Rear Bearing Hole)   | Sealant          | 1141570             |

**Table 3: Sealants, Adhesives and Lubricants**

| Application                   | Type of Material | Part No.             |
|-------------------------------|------------------|----------------------|
| Lower Intake Manifold Bolt    | Threadlock       | 1161053              |
| Throttle Body Stud            | Threadlock       | 1161053              |
| Valve Train Component Prelube | Lubricant        | 12345501 GM Part No. |
| Water Pump Bolt               | Sealant          | 1141570              |

## Tune Up Specifications

**Table 4: Tune Up Specifications 5.0GL, 5.7GL**

| Model              | Item               | Specification   |
|--------------------|--------------------|---|
| 5.0GL, 5.7GL       | Fuel Pump Pressure | 5-7 PSI (34-48 kPa)   |
|                    | Oil Capacity       | 4.5 qts w/o filter (4.7 liters)<br>5.5 qts with filter (5.2 liters)           |
|                    | Oil Pressure       | 6 - 30 PSI (41 - 207 kPa) @ 800 RPM<br>40 - 60 PSI (276 - 414 kPa) @ 3000 RPM |
|                    | Idle RPM           | 550 - 650 RPM   |
|                    | Full Throttle      | 4400 - 48 00 RPM  |
| 5.0GL-A            | Ignition Timing    | 5° BTDC with 87 AKI fuel or higher<br>10° BTDC with 89 AKI fuel or higher     |
| 5.7GL-A            | Ignition Timing    | 7° BTDC with 87 AKI fuel or higher<br>12° BTDC with 89 AKI fuel or higher     |
| 5.0GL-B/C/D/E      | Ignition Timing    | 10° BTDC (Shunt P/N 885163 required)  |
| 5.7GL-B/C/D/E      | Ignition Timing    | 12° BTDC (Shunt P/N 885163 required)  |
| 5.0GL-A, 5.7GL-A   | Spark Plug         | Volvo Penta P/N 3854399   |
| 5.0, 5.7GL-B/C/D/E | Spark Plug         | Volvo Penta P/N 3861632   |

**Table 5: Tune Up Specifications 5.0GXi-A, 5.7Gi-A, 5.7GXi-A/B**

| Model                             | Item                    | Specification   |
|-----------------------------------|-------------------------|---|
| 5.0GXi-A<br>5.7Gi-A<br>5.7GXi-A/B | Low Pressure Fuel Pump  | 8 PSI ± 4 (55 kPa ± 27)   |
|                                   | High Pressure Fuel Pump | 29 PSI ± 2 (200 kPa ± 13)   |
|                                   | Oil Capacity            | 4.5 qts w/o filter (4.7 liters)<br>5.5 qts with filter (5.2 liters)           |
|                                   | Idle RPM                | 600 RPM   |
|                                   | Full Throttle           | 4600-5000 RPM   |
|                                   | Ignition Timing         | 8° BTDC (Service Mode Required)   |
|                                   | Spark Plug              | Volvo Penta P/N 3861632   |
|                                   | Oil Pressure            | 6 - 30 PSI (41 - 207 kPa) @ 800 RPM<br>40 - 60 PSI (276 - 414 kPa) @ 3000 RPM |

**Table 6: Tune Up Specifications 5.0GXi, 5.0OSi, 5.7Gi, 5.7OSi, 5.7GXi, 5.7OSXi**

| <b>Model</b>   | <b>Item</b>             | <b>Specification</b>  |
|--|-------------------------|---|
| 5.0GXi-B/C/D/E<br>5.0OSi-B/C/D/E<br>5.7Gi-B/C/D/E<br>5.7GXi-B/C/D/E<br>5.7OSi-B/C/D<br>5.7OSXi-A/B/C/D | Low Pressure Fuel Pump  | 8 PSI ± 4 (55 kPa ± 27)   |
|  | High Pressure Fuel Pump | 50-60 PSI ± 2 (344-413 kPa ± 13)  |
|  | Oil Capacity            | 4.5 qts w/o filter (4.7 liters)<br>5.5 qts with filter (5.2 liters)           |
|  | Idle RPM                | 600 RPM   |
|  | Full Throttle           | 4600-5000 RPM   |
|  | Ignition Timing         | 10° BTDC (set by calibration, not adjustable)                                 |
|  | Spark Plug              | Volvo Penta P/N 3861632   |
|  | Oil Pressure            | 6 - 30 PSI (41 - 207 kPa) @ 800 RPM<br>40 - 60 PSI (276 - 414 kPa) @ 3000 RPM |



## Section 4: Steering System

|   |     |
|---|-----|
| Special Tools .....                                 | 163 |
| Power Steering System .....                         | 164 |
| Description .....                                   | 164 |
| Pump Operation .....                                | 165 |
| System Operation .....                              | 166 |
| Pump Removal .....                                  | 167 |
| Pump Installation .....                             | 169 |
| Hydraulic Fluid .....                               | 170 |
| Checking Fluid Level .....                          | 170 |
| Purging Air From Steering System .....              | 171 |
| Power Steering Pump Belt Adjustment .....           | 171 |
| Steering Cylinder .....                             | 172 |
| Cylinder Removal .....                              | 173 |
| Cylinder Servicing .....                            | 174 |
| Cylinder Installation .....                         | 175 |
| Cable Installation .....                            | 176 |
| Lubrication .....                                   | 177 |
| Hoses .....   | 178 |
| System Diagnosis .....                              | 178 |
| System Checks .....                                 | 178 |
| Tie Bar Adjustment - Twin Engine Installation ..... | 178 |
| Power Steering System Diagnosis Chart .....         | 179 |
| External Leakage .....                              | 180 |
| General Procedure .....                             | 180 |
| Leakage Checks .....                                | 180 |
| Easily Fixed Leaks .....                            | 180 |
| Pump Leakage .....                                  | 181 |
| Pump Pressure Test .....                            | 181 |
| Cable Installation Problems .....                   | 182 |
| Feedback To The Helm .....                          | 183 |

### Special Tools

#### Volvo Penta Special Tools

Rod Holder 3854367-4  
Pump Pulley Installer 9995444-8  
Pump Pulley Remover 9995443-0

#### Kent-Moore Special Tools

Pressure Gauge J-5176-E

Thermometer J-5421

### Sealants, Lubricants and Adhesives

Cleaning Solvent

Volvo Penta Grease

Volvo Penta Power Trim/Tilt & Steering Fluid

Volvo Penta Thread Sealing Agent

Loctite Primer



### Safety Warnings

**Before working on any part of the steering system, read the Safety section at the end of this manual.**

**When replacement parts are required, use genuine Volvo Penta or parts with equivalent characteristics including type, strength and material. Failure to do so may result in product malfunction and possible injury to the operator and/or passengers.**

**When working on an engine that is running or being cranked, use extreme care to avoid getting hands, fingers or clothing caught in the alternator, power steering supply pump and circulating pump belts, pulleys and other moving parts.**

## Power Steering System

### Description

The power steering system consists of a mechanical cable from the helm to the inner transom plate, an engine mounted pump, an oil cooler, and a power cylinder to move the sterndrive steering arm.

The hydraulic pump is mounted on the front of the engine and is belt driven by the crankshaft pulley. The reservoir fill cap has a dipstick attached.

- The control valve and cylinder is a single unit mounted to the inner transom bracket.
- The oil cooler is a heat exchanger that uses engine cooling water to keep the hydraulic fluid cool.
- A high pressure hydraulic hose carries fluid from the pump to the control valve, and low pressure hoses and carry the fluid from the valve to the oil cooler, and back to the reservoir.
- The steering cable casing attaches to the steering cylinder valve.
- The cable ram passes through the valve and attaches to the clevis. The drive steering arm is also attached to the clevis.

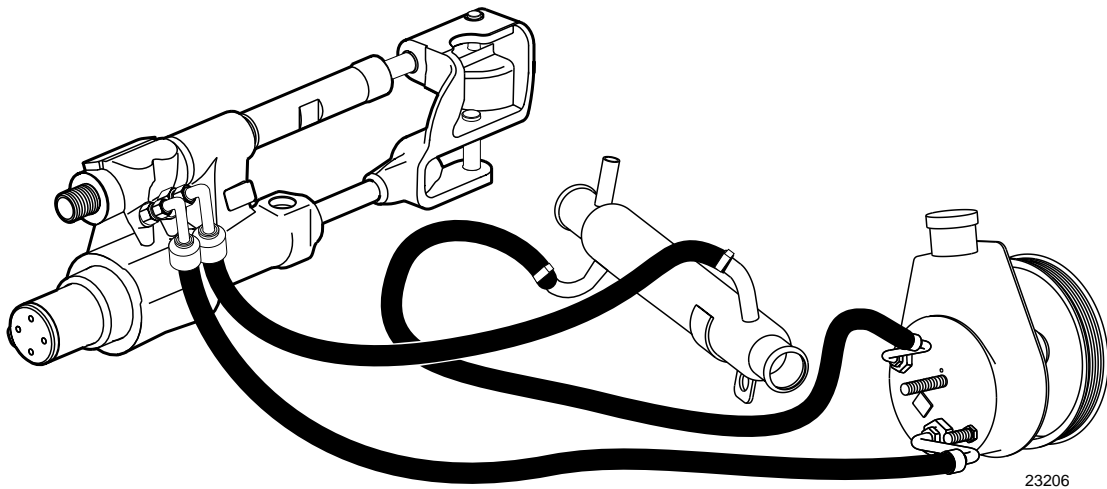

## Pump Operation

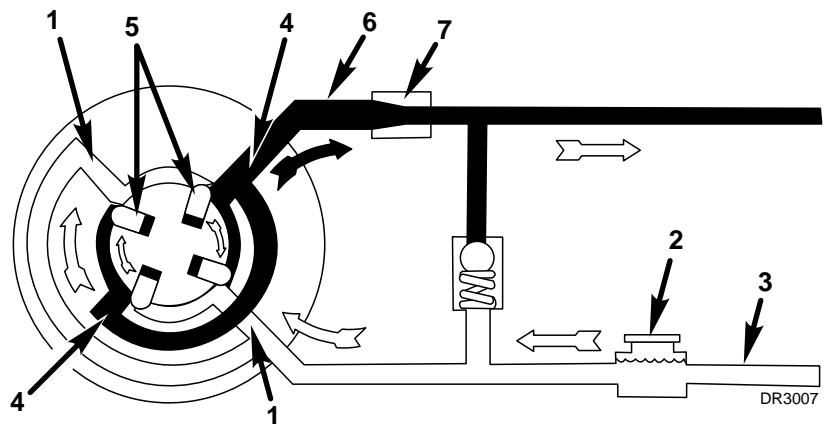

During normal operation, fluid is drawn into dual pump intake ports (1) from the reservoir (2). The reservoir is supplied by a low pressure return line (3) from the power steering oil cooler. The pump output is through ports (4). The vanes (5) are held out against the pump bore by pressure behind the vanes. The pump has sufficient output (6) to allow quick boat maneuvers even at engine idle RPM. The pump output at high RPM is limited to about 2.3 gallons per minute by a flow restriction orifice (7).

The pump output pressure is determined by the resistance to flow of the system. When no steering changes are being made, the pressure will be about 50-100 PSI. When there is steering input, the pressure will be higher and will depend on the steering forces required due to

the boat attitude, drive trim position, throttle position and quickness of the maneuver.

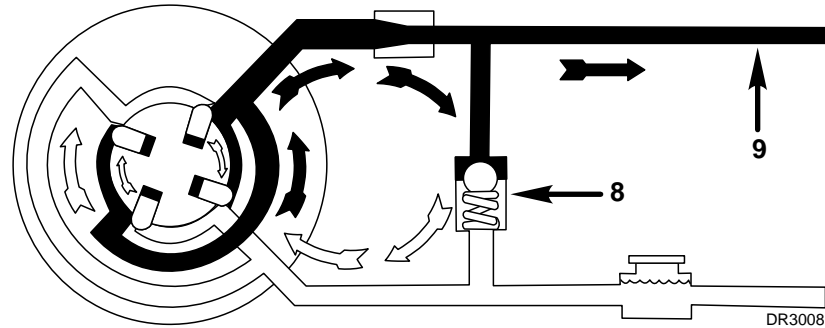

The pump is protected from the very high pressures by a pressure relief valve (8) that is located in the pump body. If the steering load becomes extremely high, the relief valve will open and limit the output pressure (9) to about 1,000-1,100 PSI.

Internal damage to the pump will occur if the system is operated at relief valve pressure for more than a few seconds.

The pump has a metric output fitting. Use only a hose with a metric fitting.

## System Operation

### No Steering Input - Steering Wheel Not Turning

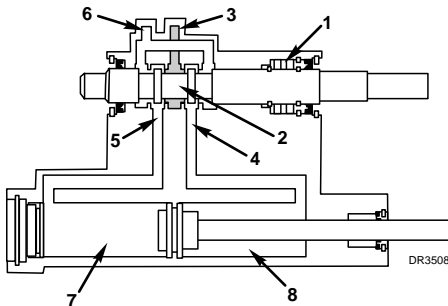

When there is no steering input from the helm, the spring (1) keeps the spool valve (2) centered. Fluid from the pump enters the control valve through the pressure port (3), flows past both cylinder ports (4 and 5) with little restriction, then through the return port (6) and back to the reservoir in the power steering pump. There is a small amount of equal force at both ends (7) and (8) of the cylinder and the cylinder does not move.

With no steering input, the sterndrive is held in one position and the boat moves in a constant turn or in a straight line.

### Steering To Port - Steering Wheel Turning To Left

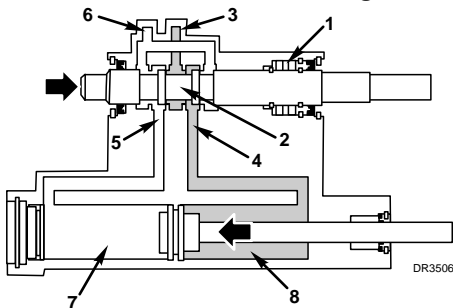

When the helm is turned to port (either turning boat to left or straightening from a right turn) the steering arm is pulled to starboard. The steering cable casing pushes the valve spool (2) to port. Fluid from the pump enters the valve at (3) and is routed to the rod-end outlet (4) and to the low volume side end of the cylinder (8). The pump pressure moves the piston and steering arm to starboard. Fluid in the high volume side of the cylinder (7) is forced out through the valve (5) from the return port (6) and back to the reservoir. As long as the helm is turning to port this motion continues, swinging the sterndrive to port.

When the helm input stops (steering wheel not turning), the steering cable stops pulling the steering arm to starboard, and the steering casing stops pushing the valve spool to port. When the spring (1) moves the valve spool to a "centered" position, hydraulic fluid is again routed past both cylinder outlets. The steering cylinder has an equal force at both ends and stops moving. The steering system is then back to the **No Steering Input** condition described previously.

### Steering To Starboard - Steering Wheel Turning To Right

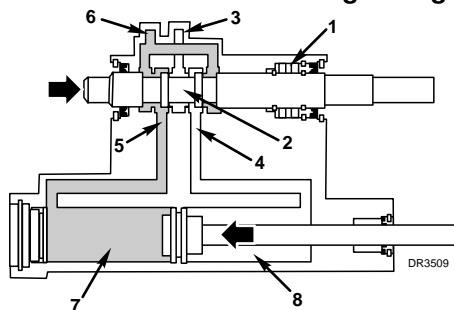

When the helm is turned to starboard (either turning boat to right or straightening from a left turn), the steering arm is pushed to port. The steering cable casing pulls the valve spool (2) to starboard. Fluid from the pump enters the valve at (3) and is routed to the piston-end outlet (5) and to the high volume side of the cylinder (7). The pump pressure moves the piston and steering arm to port. Fluid at the low volume side of the cylinder (8) is forced out and through the valve from (4) to return port (6) and back to the reservoir. As long as the helm is turning to starboard this motion continues, swinging the sterndrive to starboard.

When the helm input stops (steering wheel not turning), the steering cable stops pushing the steering arm to port, and the steering casing stops pulling the valve spool to starboard. When the spring (1) moves the valve spool valve to a “centered” position, hydraulic fluid is again routed past both cylinder outlets. The steering cylinder has an equal force at both ends and stops moving. The steering system is then back at the No Steering Input condition described previously.

### Steering Without Power Assist

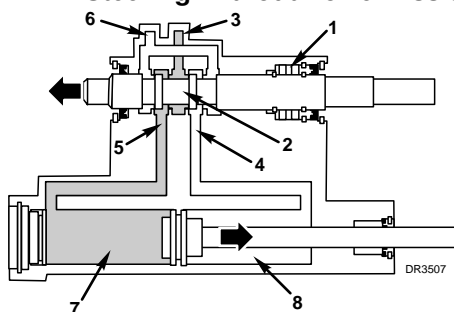

If the steering system is not providing power assist, the operator may still steer the boat. Turning the steering wheel to port causes the steering cable to pull the steering arm to starboard. This causes the cable casing to push the valve spool valve (2) to port against the stop about 0.125 in. (3,18 mm). The steering cable then transmits the full manual effort to pull the steering arm.

The fluid (7) ahead of the piston is forced out of the cylinder through outlet (5) into the valve, and through return port (6) back to the reservoir. Additional fluid is drawn out of the reservoir through the pressure inlet (3) and (4) to the opposite side of the piston.

More steering effort is required since all of the power required to steer the boat must be supplied by the operator, and additional force is required to move the fluid through the system when the pump is not operating.

## Pump Removal

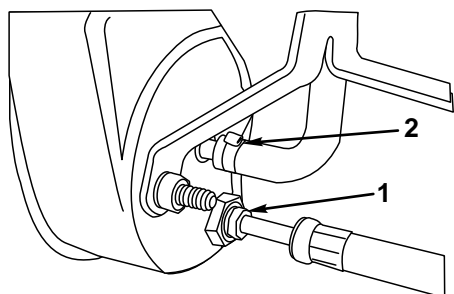

1. Place an oil drain pan under pump. Disconnect high pressure hose (1) and return hose (2) at pump. Do not lose O-ring on pressure hose fitting. Secure hose ends in a raised position to prevent fluid draining from hoses. Cap or tape ends of hoses to keep out dirt. Drain pump completely before removing.

**NOTE!** Some engine models may have the return line secured with a crimp style clamp. This type clamp is disposable and must be replaced with a worm screw type hose clamp during reassembly.

## Serpentine Belt Models Only

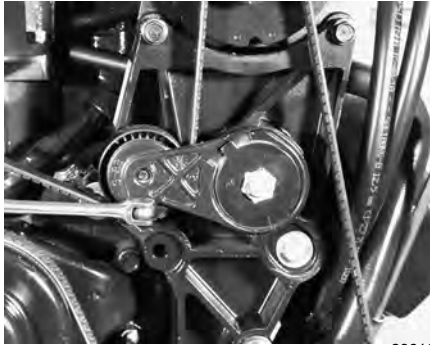

23916B

1. On models with serpentine belt, release tension on the belt tensioner and remove the belt.

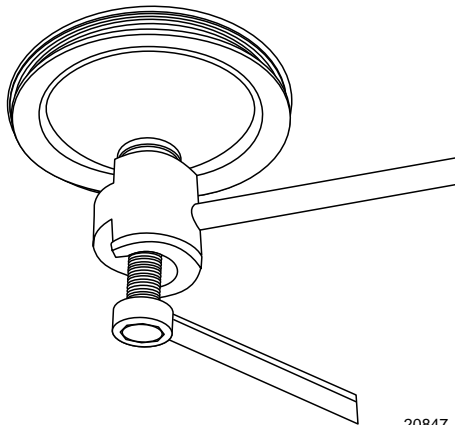

20847

2. Remove pump pulley using special tool Volvo Penta P/N 9995443.

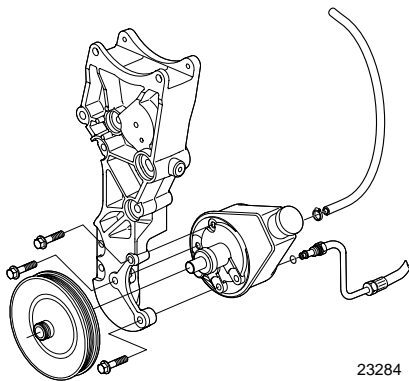

23284

3. Remove three bolts securing pump to mounting bracket and remove pump.

**V-Belt Models Only**

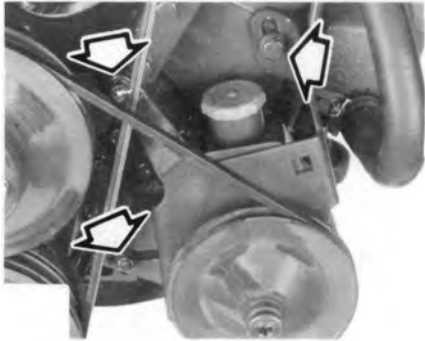

20496A

4. Loosen pump bracket mounting screws and remove drive belt.
5. Remove pump mounting screws and remove pump from engine.

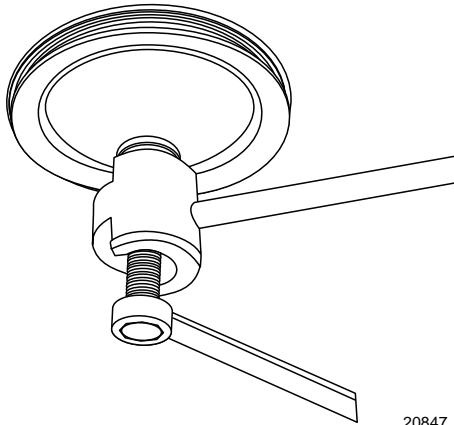

20847

6. Remove pump pulley using Pulley Remover, Volvo Penta P/N 9995443, then remove bracket from pump.
7. Remove mounting screws that secure the bracket to the pump and remove bracket.

**Pump Installation**

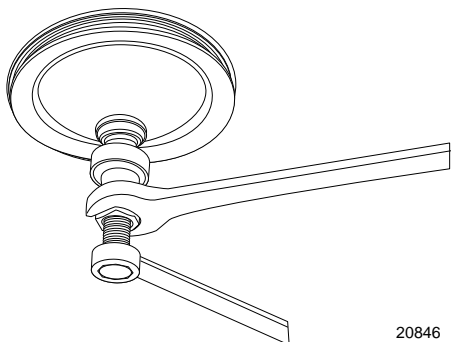

20846

1. Attach mounting bracket to pump.
2. Attach pulley using Pulley Installer, Volvo Penta P/N 9995444-8.
3. Mount pump bracket loosely on the engine.
4. Make sure O-ring is in place and in good condition, then connect high pressure hose fitting. Tighten fitting to 15-26 ft. lb. (20-35 N•m).
5. Connect return hose to reservoir. Tighten hose clamp to 12-17 in. lb. (1,4-2,0 N•m).

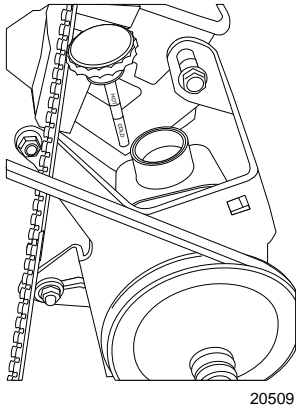

6. Fill pump reservoir with Volvo Penta Power Trim/Tilt & Steering Fluid. Bleed pump, hoses, and valve by turning pulley clockwise (as viewed from front of engine) until reservoir no longer shows air bubbles. Keep reservoir filled while purging air from system.

### Serpentine Belt Models Only

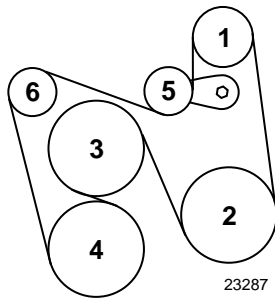

Release belt tensioner and install belt as shown.

- 1 Alternator
- 2 Power steering pump
- 3 Circulating water pump
- 4 Crankshaft
- 5 Belt tensioner
- 6 Idler Pulley

### V-Belt Models Only

7. Install drive belt and adjust belt tension See "Power Steering Pump Belt Adjustment" on page 171. Do not pry against pump reservoir while tightening belt.
8. Bleed entire system as outlined under Purging Air From Steering System.

## Hydraulic Fluid

### NOTE!

**Only use approved power steering fluid such as Volvo Penta Power Trim/Tilt & Steering Fluid. If this fluid is not available, use an automatic transmission fluid labeled Dexron or Dexron II.**

### Checking Fluid Level

1. Run engine and rotate steering wheel lock-to-lock for a reasonably long period of time to warm up steering fluid, then shut engine off. Remove reservoir filler cap and check if fluid level is at "HOT" mark on dipstick.
2. If fluid level is low, add recommended hydraulic fluid to bring fluid up to "HOT" mark on dipstick. Replace filler cap.



**Caution!**



**Do not overfill a cold reservoir. Fluid could overflow when system reaches operating temperature.**

## Purging Air From Steering System

When system components have been serviced, pump must be refilled with fluid before engine is started. Perform the following steps to purge air from the steering system.



### **Caution!**

**Do not run pump even momentarily without fluid. Pump will be ruined or severely damaged.**

1. With engine "OFF," turn helm all the way to port. Add power steering fluid to bring fluid level to "COLD" mark on dipstick.
2. Start engine, run momentarily and shut off engine. Recheck fluid level and fill to "COLD" mark. Repeat this step as necessary until system no longer requires additional fluid.
3. Complete purging of air from system by starting engine and turning wheel slowly lock-to-lock. Maintain fluid level above pump body in reservoir.
4. Returning fluid with air in it will often be in the form of foam and will have a light tan or red appearance. Maintain fluid level high enough so foam is not drawn into pump inlet. All air must be eliminated from fluid before normal steering action can be obtained. If excessive foam accumulates in reservoir it must be removed, or let unit stand for an hour and repeat steps above.
5. After all air has been purged, return wheel to centered position. Continue to run engine for several minutes and then shut engine off.
6. With engine "OFF" and with fluid at normal operating temperature, recheck to make sure fluid level is at "HOT" mark on dipstick.
7. Water test the boat to make sure the steering functions normally and is free from noise.

## Power Steering Pump Belt Adjustment

**Serpentine Belt Models** The belt tension is maintained by a belt tensioner. No adjustment is necessary.

## V- Belt Models

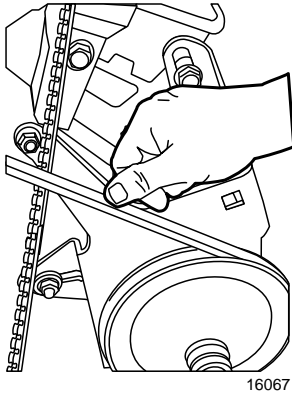

### Caution!

**Improper power steering belt adjustment will cause a loss of power steering assist, resulting in hard steering.**

Check power steering belt tension midway between the circulating pump pulley and the power steering pump pulley.

To increase belt tension: Loosen pump mounting bracket screws, insert a 1/2 in. breaker bar into the square hole in the pump mounting bracket, and pivot pump away from engine as shown. While maintaining pressure on pump, retighten all mounting screws. Recheck belt tension. Never pry against the pump reservoir or pull filler neck.

**NOTE! The belts used for the power steering pump are heavy-duty. DO NOT replace with automotive belts.**

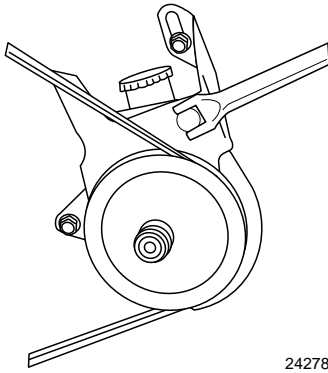

## Steering Cylinder

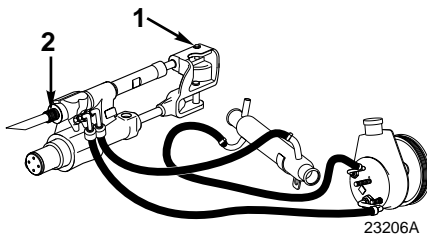

The steering cylinder assembly is a combination power cylinder and control valve. A piston rod clevis (1) provides the attachment to the steering arm and steering cable ram. The steering cable casing attaches to the threaded valve (2).

## Cylinder Removal

1. Turn helm to port full lock position. Remove the cotter pin (1) and the steering cable pin (2).

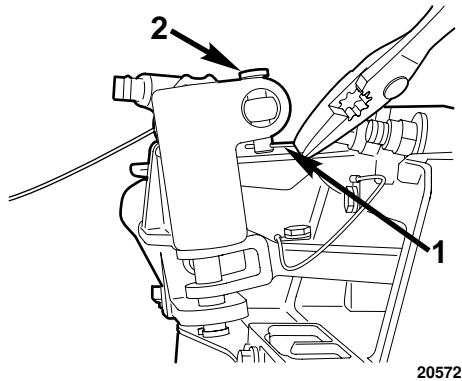

2. Hold steering tube with wrench. Loosen steering cable anchor nut and pull steering cable out of valve.

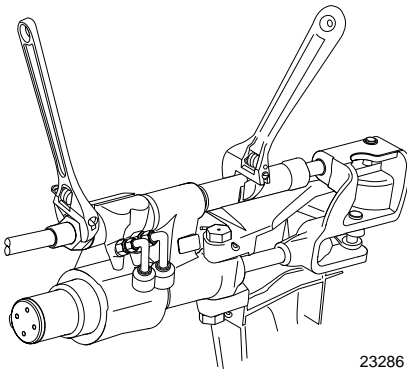

3. Remove cotter pin, then pull pin out of clevis and steering arm.

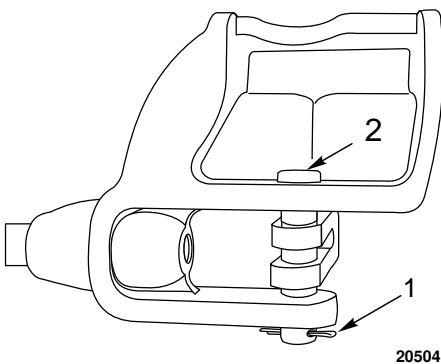

4. Remove both hose fittings from the valve. Raise hoses and cover the ends to keep out dirt.



### Caution!

Do not move cylinder rod in or out until cylinder has been drained completely. A dangerous spray of fluid can discharge from the cylinder ports if the rod is moved in or out.

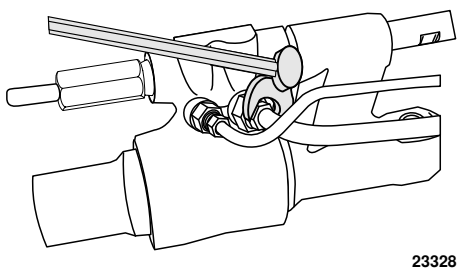

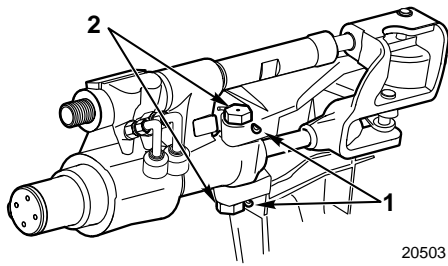

20503

5. Remove cotter pins (1) and loosen both anchor screws (2) until steering cylinder assembly can be removed.

### Cylinder Servicing

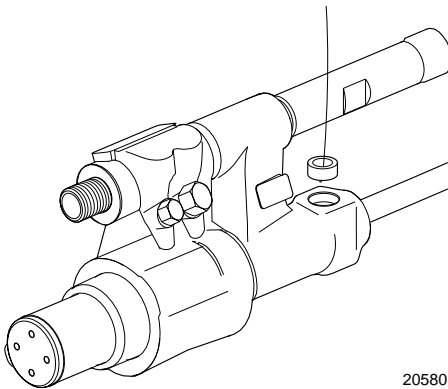

20580

1. Pry out steering pivot bushings if they are to be replaced. If necessary they may be carefully drilled in two places with a 1/16 in. (1,5 mm) drill bit and then removed.
2. New bushings should be lubricated and pushed into place.

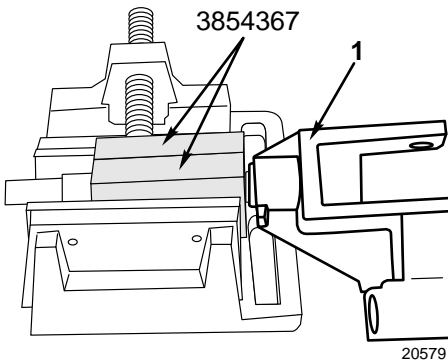

20579

3. The cylinder rod should be wrapped with heavy paper or pasteboard and held in a vise with Rod Holder, Volvo Penta P/N 3854367-4. To remove unscrew the clevis (1).
4. To reinstall clevis, coat threads with Volvo Penta locking fluid P/N 1161053 and tighten to 23-28 ft. lb. (31-38 N•m).

## Cylinder Installation

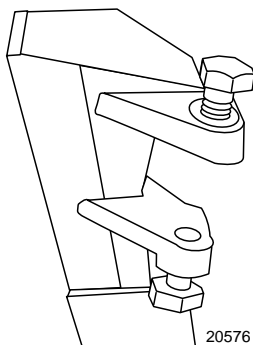

20576

**NOTE!** If cylinder is being replaced due to fluid contamination, be sure to flush system of contamination before installing a new cylinder.

1. Install anchor screws flush with inside of inner transom bracket.

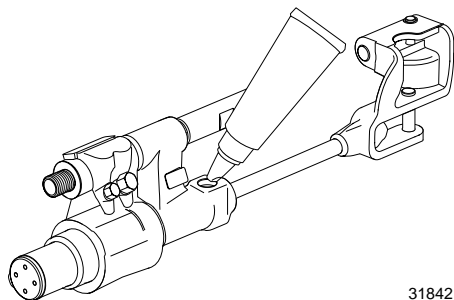

31842

2. Apply Volvo Penta Grease to both bushings.



### Caution!

Filling the bushing pockets full with grease can cause the screws to hydraulically lock and break the transom plate when tightened.

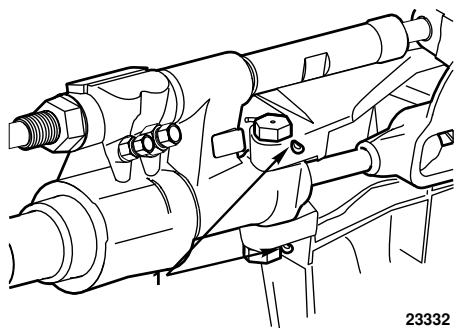

23332

3. Position steering cylinder assembly on inner transom bracket. Align bushings of steering cylinder with screws. Hand tighten the anchor screws before final tightening with a torque wrench to ensure alignment and engagement into bushings. Tighten anchor screws to 40-45 ft. lb. (54-61 N•m).
4. Install cotter pins through holes (1) in transom bracket from transom side. Spread ends of cotter pins to secure.



### Caution!

Do not move cylinder rod if cylinder contains any fluid. A dangerous spray of fluid may discharge from the ports.

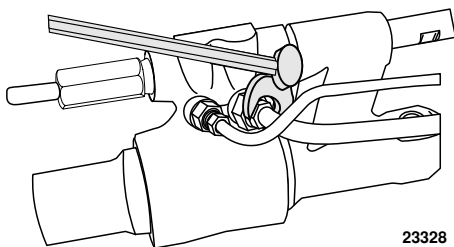

23328

5. Connect hoses to cylinder. Start each fitting by hand. Tighten pressure fitting to 10-12 ft. lb. (14-16 N•m). Tighten return fitting to 15-17 ft. lb. (20-23 N•m).

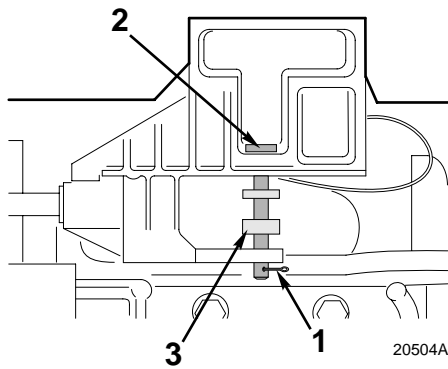

6. Pull steering arm (3) into hydraulic cylinder clevis. Align holes and install large pin (2) from top of arm. **Secure large pin by installing and spreading ends of cotter pin (3).**

## Cable Installation

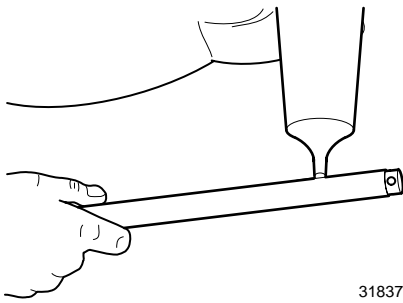

1. Turn the steering wheel to fully extend the steering cable ram to its maximum extension. Lubricate the full length of the steering cable ram with Volvo Penta Grease.

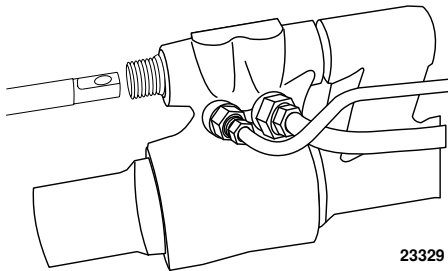

2. Retract steering cable ram and insert ram through valve.

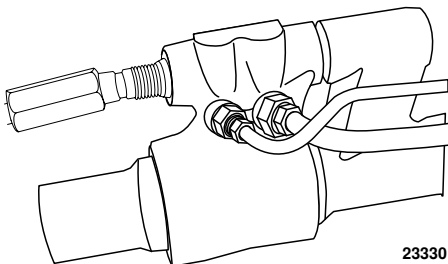

3. Hold steering cable anchor nut back on cable casing to make certain the steering cable is completely seated in end of valve.

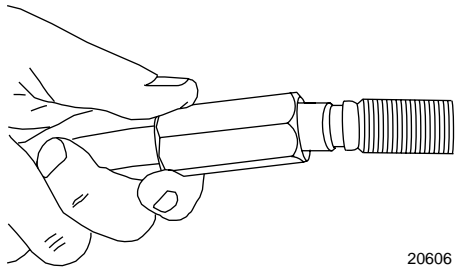

20606

4. While holding steering cable tight against valve, thread steering cable anchor nut onto valve until snug.

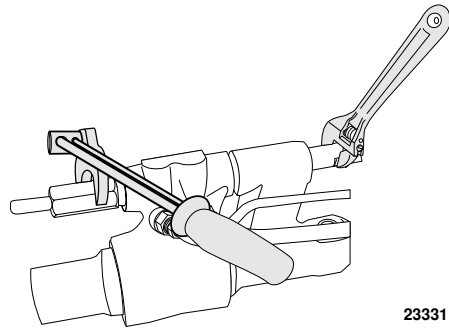

23331

5. Hold cable tube with a 22 mm wrench on the flat. Attach a crow-foot wrench at 90° to a torque wrench and tighten the steering cable anchor nut to 120 in. lb. (14 N•m).

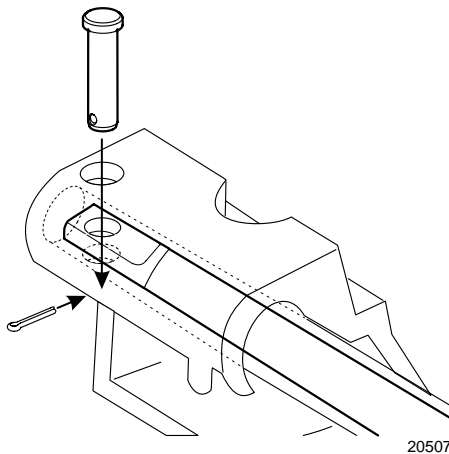

20507

6. Align cable ram with steering cylinder clevis and install small pin from top of clevis. Secure small pin by installing and spreading ends of cotter pin.
7. Fill system with fluid and remove all air. See "Purging Air From Steering System" on page 171.

**Warning!**

**Ensure all steering system cotter pins are properly installed and secure.**

## Lubrication

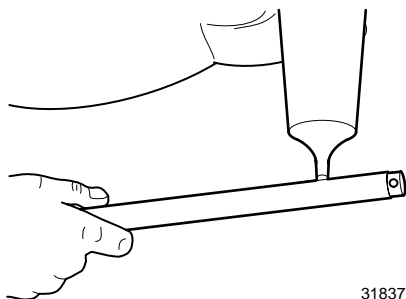

31837

Lubricate the steering ram with Volvo Penta Grease every 50 hours or once a season, whichever comes first.

Due to local conditions, it may be necessary to lubricate your steering ram at more frequent intervals.

## Hoses



### Caution!

**Do not start engine with any power steering hose disconnected.**

The pump output fitting has metric threads. Do not attach a hose with SAE threads to the pump fitting.

After connecting power steering hoses, make sure that there's ample clearance between the hoses and drive belts and other components. Hoses installed out of position may rub during operation and be damaged.

If fluid return hose is removed at pump, be sure to use a "worm drive" clamp when reinstalling it.

## System Diagnosis

Complaints of faulty steering are frequently the result of problems other than the steering cylinder assembly or pump. Conditions such as hard or loose steering, or vibrations, are often related to such factors as the drive belt; pump and cylinder mounting; fluid level; or incorrect installation of the steering cable. These factors should be checked and corrected before disassembling or replacing parts of the steering system.

## System Checks

Many factors affect power operation of the steering system. Some of the most common problem areas are:

- Fluid level.
- Loose or worn drive belt, or oily belt.
- Steering cable jammed against something in boat at stern.
- Steering cable too short or steering cable too long.
- Loosely mounted components.
- Loose pump pulley.

## Tie Bar Adjustment - Twin Engine Installation

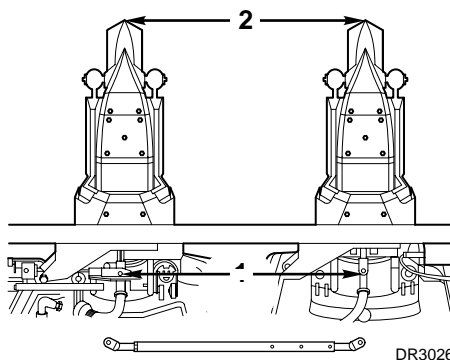

On deep Vee shaped boat hulls, a toe-in condition should be created for improved performance and efficiency. A commonly used toe-in condition is one in which dimension (1) will be 1/4 to 3/8 in. (6,35 to 9,53 mm) less than dimension (2).

**NOTE! Hold tension on the sterndrives when measuring.**



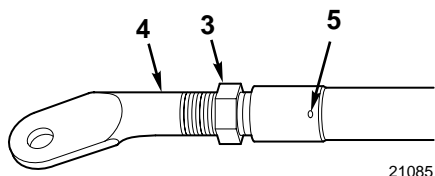

Remove the steering tie bar from the port tiller arm. Loosen jam nut (3). Turn jam nut out 1/16 to 3/32 in. (1,59 to 2,38 mm) as required, and screw in steering tie bar end. Retighten the jam nut.



**Caution!**

**Threads of the port tie bar must be visible through the inspection hole (5) to insure adequate thread engagement between the rod and tube. Failure to ensure proper threads engagement could result in component failure resulting in possible loss of steering control.**

**Power Steering System Diagnosis Chart**

**Table 1:**

| Condition                | Possible Cause  | Correction  |
|--------------------------|---|---|
| <b>SYSTEM NOISE:</b>     |   |   |
| Pump noise "chirp."      | Loose belt. <sup>a</sup>  | Adjust belt tension to specification.   |
| Belt squeal.             | Loose belt. <sup>a</sup>  | Adjust belt tension to specification. <sup>a</sup>  |
| "Hissing" sound.         | Some noise exists in all power steering systems. "Hiss" may be expected when turning the steering wheel, particularly at low speed. | "None; a slight "hiss" is normal and in no way affects steering.                                |
| Rattle                   | Pressure hose touching other parts of engine.   | Adjust hose position.   |
| Rattle or chuckle.       | Steering system looseness.  | Check cable nut and cylinder pivot points for wear or looseness. Replace bushings if necessary. |
| Groan                    | Low fluid level.  | Find and repair leak. Fill reservoir and bleed system.  |
|                          | Air in fluid.   | Fill reservoir, find and repair leak. Check connections, bleed system.                          |
| Growl                    | Excessive back pressure caused by hose restriction.   | Locate restriction and correct. Replace part if necessary.                                      |
| Pump growl               | Incorrect steering cable adjustment. Cable to boat interference.  | Adjust cable per procedure. Eliminate interference.   |
| Whine in pump.           | Pump shaft bearing scored.  | Flush system, replace pump.   |
| <b>SYSTEM OPERATION:</b> |   |   |

Table 1:

| Condition  | Possible Cause                   | Correction   |
|--|----------------------------------|--|
| Excessive wheel kickback or loose steering (not boat wander).  | Steering cable attachment loose. | Replace pin. Tighten steering cable anchor nut.                      |
|  | Air in system.                   | Add fluid to pump reservoir and bleed system. Check all connections. |
| Steering wheel surges or jerks when turning with engine running, especially during slow speed operation. | Loose pump belt.                 | Adjust tension to specification.                                     |
|  | Air in fluid.                    | Fill reservoir, find and repair leak. Bleed system.                  |
|  | Insufficient pump pressure.      | Replace pump if defective.   |
| Momentary increase in effort when turning wheel fast to right or left.                                   | Pump belt slipping.              | Tighten or replace belt. If oily, fix leak.                          |
|  | Low fluid level.                 | Fill reservoir and bleed system.                                     |
|  | High internal leakage.           | Replace pump if defective.   |

a. Does not apply to serpentine belt systems

## External Leakage

### General Procedure

1. Wipe suspected area dry.
2. Check for overfilled reservoir.
3. Check for fluid aeration and overflow.
4. Check hose connections - tighten if necessary.
5. Determine exact point of leakage.
6. When service is required, replace component.

### Leakage Checks

Although some leaks are easily found, seepage type leaks may be difficult to pinpoint. Locate seepage leaks as follows:

1. With the engine off, wipe the complete power steering system dry (pump, hoses, and connections).
2. Check the fluid level in the pump reservoir and adjust as directed.
3. Start the engine and turn the steering wheel from stop-to-stop several times.
4. Find the exact area of leakage.

### Easily Fixed Leaks

1. Loose clamp on pump return hose.
2. Loose pump or cylinder hose fitting. If fittings are not cross-threaded, tighten to correct torque. See Torque Specifications.
3. Damaged O-ring on pump pressure fitting. Replace O-ring.
4. External leakage of power cylinder. Replace power cylinder.
5. Leakage of fluid in cooling water. Replace oil cooler.

6. Damage or cracked hose. Replace hose.

If the return hose is removed, the clamp must be replaced with a worm drive clamp. Replace leaky hoses.

## Pump Leakage

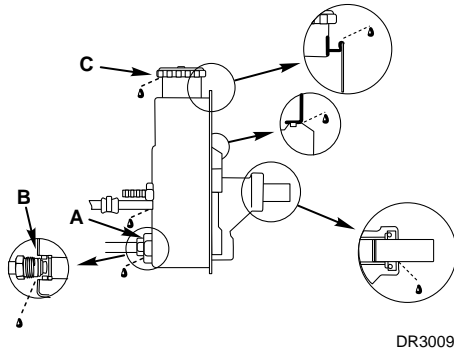

DR3009

1. An overfilled pump reservoir can cause a leak. The fluid in the steering system expands as it heats up during normal usage and fluid level rises in reservoir. Excess fluid is forced through the breather cap hole where it may be sprayed over the engine by the drive belt.
2. Install new O-ring. Tighten hose fitting (A) to 15-26 ft. lb. (20-35 N•m). If leakage persists, replace pump or hose as required.
3. Check torque on fitting (B). Tighten to 37-75 ft. lb. (50-102 N•m). If fitting is not loose, replace pump.
4. Check fluid level (C). If leakage persists with fluid at correct level and cap tight, replace cap or pump.
5. Some non-repairable pump leakage areas are marked with the oil-drop symbol. If leakage occurs in these areas, replace pump.

## Pump Pressure Test

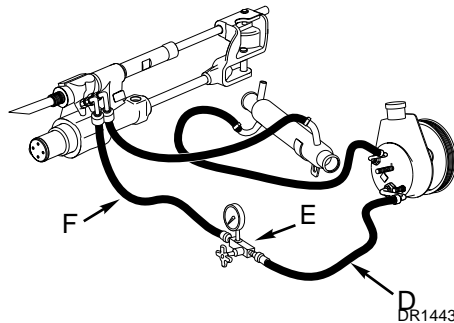

DR1443

1. With engine off, disconnect high pressure (output) hose at pump. Use a spare pressure hose (D) to install Kent-Moore Tool, J-5176 (E) between pump and steering cylinder pressure hose (F). Gauge must be positioned between shutoff valve and pump. Connect steering cylinder pressure hose to shutoff valve. Open shutoff valve.
2. Remove filler cap from pump reservoir and check fluid level. Fill pump reservoir to full mark on dipstick. Start engine, momentarily hold steering wheel against stop, and check connections at tool for leakage.
3. Bleed system as outlined under Purging Air From Steering System.
4. Insert Kent-Moore Thermometer Tool, J-5421 into reservoir filler opening. Start the engine and move steering wheel from stop-to-stop several times until thermometer indicates that hydraulic fluid has reached its normal operating temperature of approximately 150° to 190° F (65° to 88° C).
5. Check fluid level; add fluid if required. When engine is at normal operating temperature, the pressure reading on the gauge (valve open) should be in the 50-100 PSI (345-690 kPa) range. If pressure exceeds specifications, check the hoses for restrictions.
6. Pump relief valve pressure can be checked by momentarily closing the shutoff valve. Do not leave valve closed longer than it takes to read gauge; high hydraulic pressures are developed. Relief valve pressure is approximately 1000-1100 PSI (6895-7584 kPa).

Replace pump if fluid pressures or temperature do not meet specifications.

## Cable Installation Problems

The hydraulic valve reacts to steering cable casing movement. Total valve movement is about 1/4 inch. This small motion is sufficient to operate the valve and direct hydraulic pressure to the appropriate side of the steering cylinder. Any restriction of movement of the steering cable casing at the stern of the boat will limit or restrict the movement of the valve and will result in hard steering in one or both directions.

When replacing the steering cable, the following points must be followed for proper power steering system operation:

1. Do not install a cable that is too short. Inadequate length will put tension on the cable casing, and cause binding of the steering cable. This will restrict valve movement, cause hard steering to port and a tendency to self steer to starboard.

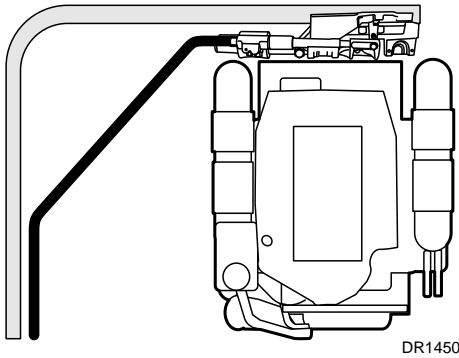

2. Do not install a cable that is too long. Excessive length will push on the cable casing, and cause binding of the steering cable. This will restrict valve movement, cause hard steering to starboard and a tendency to self steer to port.

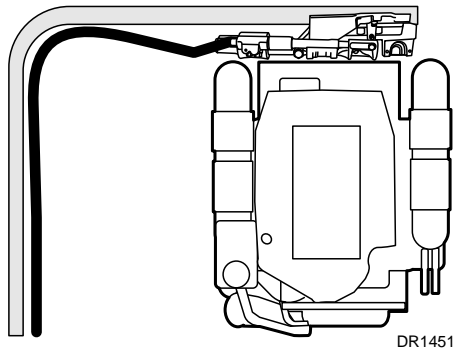

3. Do not position steering cable in a sharp bend of less than 6 in. radius. Tight bends will cause binding and limit control valve movement. This will contribute to hard or uneven steering, or rough steering wheel movement.

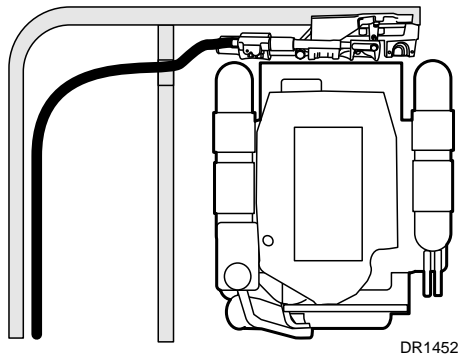

4. Do not jam anything against cable at the engine end. Do not bind cable against inside of boat or against fuel tanks, battery boxes or flotation blocks. Jamming the steering cable will restrict steering cable movement and cause hard steering.

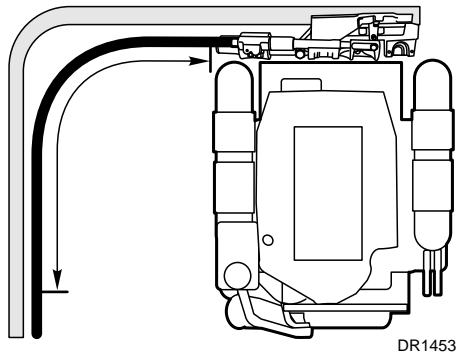

5. Do not interfere with or restrict steering cable movement through the last 90° of bend to the engine. Cable retainers, clips, clamps or tie straps should not be used in a manner that will restrict the cable movement near the engine. Do not attach wiring harness or control cables to this end of the steering cable.

**NOTE! Do not restrict steering cable casing movement. Any restriction of the cable also restricts the valve movement. This will limit or stop hydraulic assist, or may hold the valve in one steering mode.**

## Feedback To The Helm

The steering system requires at least a little friction in the helm (and cable) to prevent hydrodynamic forces on the gear case from feeding back and turning the steering wheel without the operator activating the power assist system. This may happen on single engine installations (or on twin engines having both drives rotating in the same direction).

Run the boat in a straight line in opposite directions at normal cruising speed with the drive trimmed in both a “bow up” position and in a “bow down” position. In each trim position, momentarily release the steering wheel to see if the wheel is turned by the gear case, and in which direction.

If the steering wheel turns to both starboard and port, then helm friction must be increased slightly. This will allow the power steering system to hold the desired steering position.

If the helm always turns in one direction (when it turns), it may be caused by a steering cable that is too short, too long, or has restricted movement. See Cable Installation Problems. Twin engine problems may be corrected by adjusting the tie bar for “toe-in” or for “toe-out” of the sterndrives. Refer to Tie Bar Adjustment found in this section.

# NOTES

A series of horizontal dashed lines for taking notes.

# Section 5: Throttle & Shift Control System

- Installation of Shift and Throttle Cables ..... 185
  - Check Remote Control Shift Cable Stroke ..... 186
  - Installation of SAE Cables to Engine/Drive ..... 186
  - Throttle Cable to Engine ..... 189
- Neutral Start Switch Tests ..... 191
  - Electrical ..... 191
  - Mechanical ..... 191
- Removal of SAE Remote Control Cables ..... 191
  - Throttle Cable From Engine ..... 192
  - Shift Cable From Sterndrive ..... 192

## Installation of Shift and Throttle Cables

Shift cable should "PULL" for forward gear on right-hand rotation SX and DP-S propeller applications. Shift cable should "PUSH" for forward gear on left-hand rotation SX propeller applications. Throttle cable should "Push" to close for Volvo Penta remote controls. Failure to do so could result in loss of control of the boat and possible injury to the boat occupants.

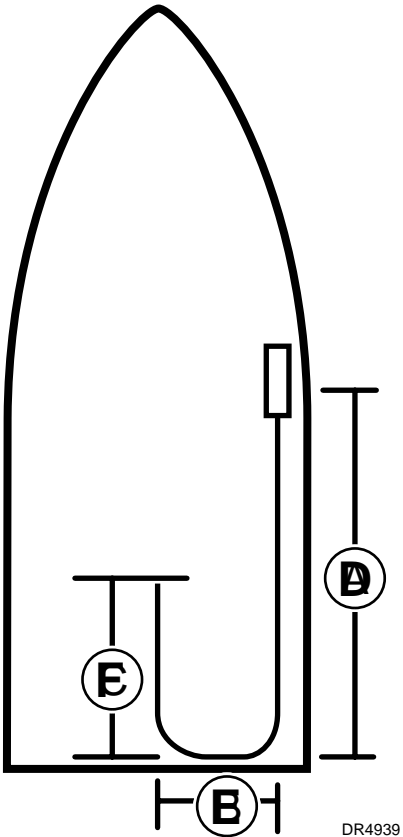

1. If the remote control shift and throttle cables are installed in the remote controls, proceed to Check Remote Control Shift Cable Stroke.
2. If the remote control shift and throttle cables have not been installed, the following procedure will permit you to order the correct length remote control shift and throttle cables.
3. Measure the proposed route of the remote control shift and throttle cables. All bends must have a radius greater than 6 inches (15,2 cm).
  - Remote control shift cable: Add (A)+(B) plus 20 in. (50.8 cm), round up to next cable length.
  - Remote control throttle cable: Add (A)+(B)+(C) plus 4 in. (10.1 cm), (C is to center of throttle arm pin). Round up to next cable length.

**⚠ Caution!**  
**When removing shift and throttle cables from the packing box, DO NOT bend the cables tighter than a 6 inch radius.**

**Check Remote Control Shift Cable Stroke**

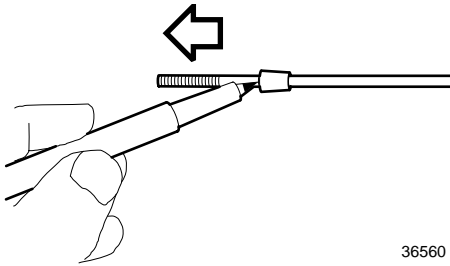

36560

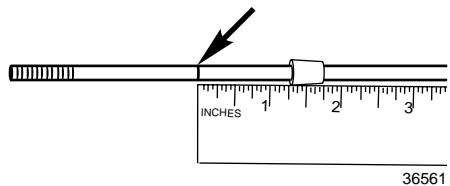

36561

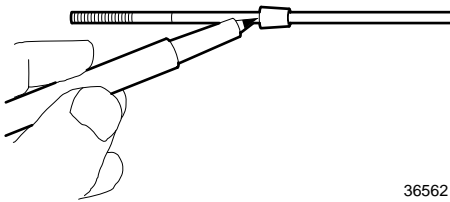

36562

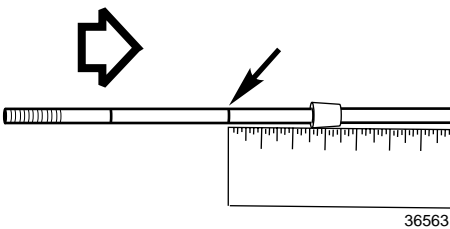

36563

1. Move the remote control handle to the wide-open-throttle position in the direction needed to retract the shift cable. Pull out cable core wire to remove end play. Mark cable core wire at end of casing.
2. Return remote control shift handle to the neutral detent position. Measure and record the distance between the mark and end of casing.
3. Mark cable core wire at end of casing with control in the neutral detent position.
4. Move the remote control handle to the wide-open-throttle position in the direction needed to extend the shift cable. Push in on cable core wire to remove end play. Measure and record the distance between mark and end of casing.
  - The distance between forward and neutral must be no less than 1¼ in. (31.8 mm) and no greater than 13/8 in. (35.0 mm).
  - The distance between neutral and reverse must be no less than 1¼ in. (31.8 mm) and no greater than 13/8 in. (35.0 mm).

**NOTE!** Check your remote control installation instructions, if your measurements are not within these specifications. Make sure the cables are attached correctly inside the control box and move in the proper direction for your application before continuing. Refer to the remote control installation instructions for this information. All control boxes must meet these minimum and maximum specifications in order for the shift system to function properly.

**Installation of SAE Cables to Engine/ Drive**

**NOTE!** If the throttle cable is attached to the throttle arm and anchor block, remove it from both. The throttle cable must be disconnected from the throttle arm prior to shift cable installation and adjustment to prevent “loading” the control box and adversely affecting shift adjustments.



Before beginning, shift remote control handle into NEUTRAL detent position; the propellers should rotate freely.

**NOTE! Remote control shift and throttle cables must be SAE type cables.**

**Shift Cable to Sterndrive**

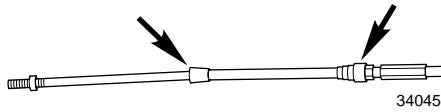

1. Note position of small seal and large seal on the shift cable, Remove and retain jam nut, small seal, and large seal from the shift cable.

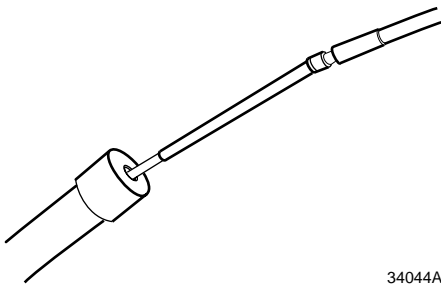

2. Apply a light coat of Volvo Penta Grease to the end of the remote control shift cable casing. Slide shift cable through shift cable tube until it appears on the outside of the transom.

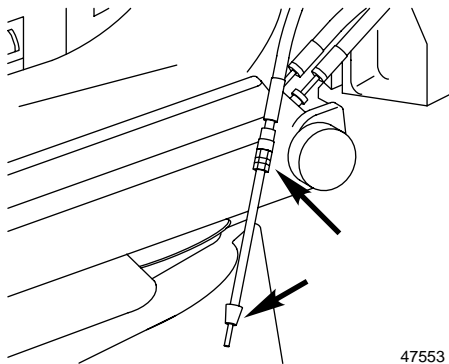

3. For ease of installation of shift cable, turn sterndrive to port. Reinstall the retained large seal and small seal onto the shift cable in the same position as noted in step 1.

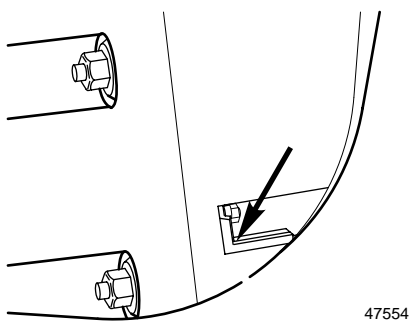

4. Loosen cable clamp screw and pull clamp out.

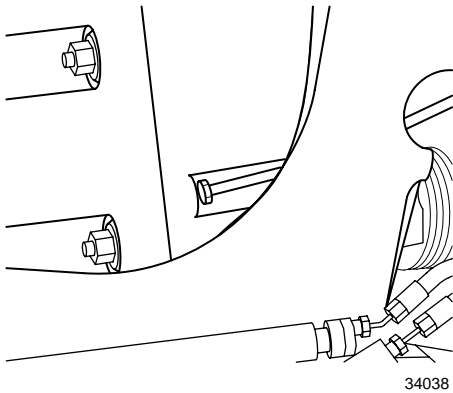

5. Slide shift cable through pivot housing and sterndrive. Slide clamp in fully, engaging the shift cable anchor groove. Tighten clamp screw securely.

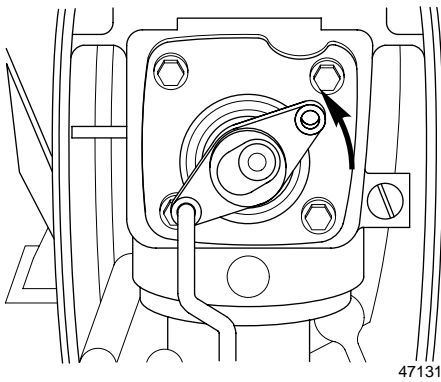

6. Rotate shift lever to extend bell crank.

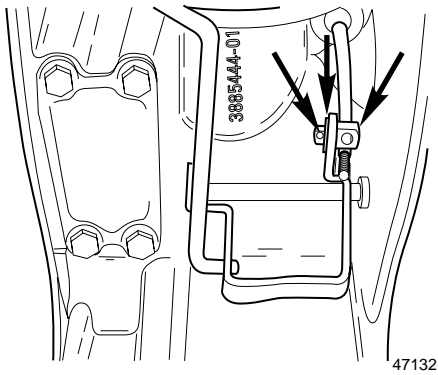

7. Remove cotter pin, flat washer, and anchor pin.

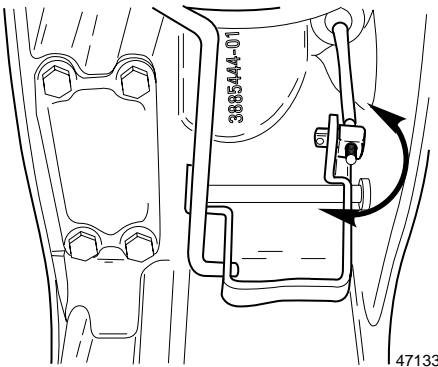

8. Thread anchor pin halfway onto remote control cable end.

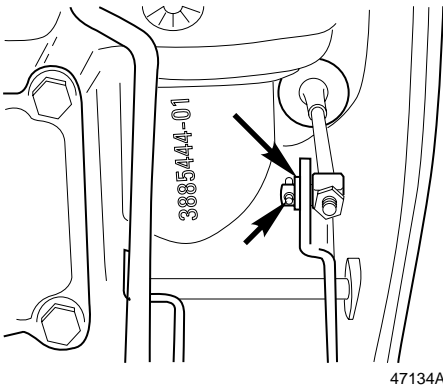

9. Rotate shift lever back to neutral detent position, then move remote control handle to its neutral detent position. Turn anchor pin IN or OUT until it aligns with center of bell crank slot.
10. Install anchor pin, flat washer, and cotter pin. Spread prongs of cotter to secure anchor pin. Install jam nut and tighten securely against anchor pin.

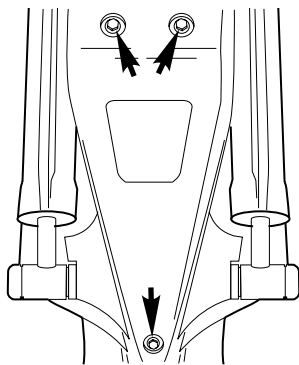

11. Reinstall rear cover and secure with three original screws. Tighten screws to 108-132 in. lb. (12-15 N•m).

### Throttle Cable to Engine

Determine whether you have a “push-to-close” or “pull-to-close” remote control system. Cable attachment point at throttle arm is determined by direction of control cable movement. Incorrect attachment may cause hazardous boat operation.

**NOTE! The remote control shift cable must be installed prior to throttle cable installation. This will ensure proper throttle and shift system operation when using single lever controls.**

1. Position control handle in **NEUTRAL** and propeller should rotate freely. Turn propeller shaft and shift into the **FORWARD** gear detent position, then pull handle **HALFWAY BACK** towards **NEUTRAL**. This positions the control for proper throttle adjustment. Failure to follow this procedure can result in “hard shifting” out of **NEUTRAL**.
2. Make sure throttle lever is against idle stop screw.
3. Align internal bosses of trunnion with throttle cable groove. Press trunnion on throttle cable until seated.

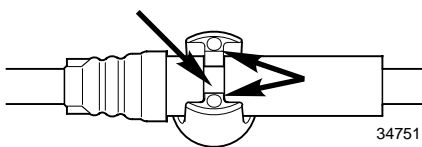

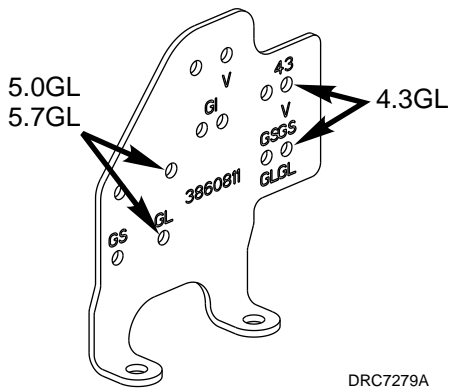

4. GL and Models: The engine throttle cable anchor block bracket has several sets of anchor block holes. The sets of holes marked with a "V" are used for Volvo Penta engines. The set of holes marked "43" are for 4.3 GL models. Holes marked GL are for all 5.0 and 5.7 Liter, GL models.

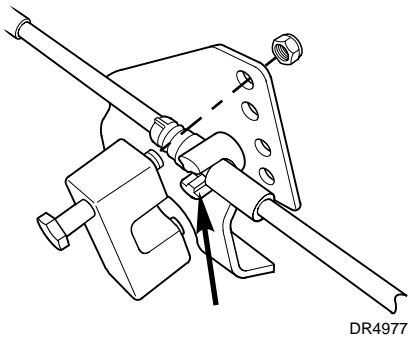

5. 5.0GXi-A, 5.7Gi-A, 5.7GXi-A/B Models have the throttle cable bracket mounted port and aft on the intake manifold.

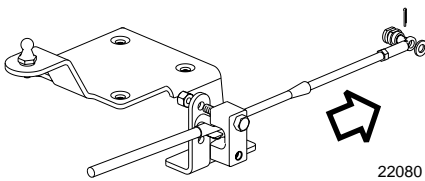

6. 5.0GXi-B/C/D/E, 5.7Gi-B/C/D/E, 5.7GXi-B/C/D/E Models: The engine throttle cable anchor block bracket is part of the fuse box mounting bracket and is located starboard and aft on the intake manifold.

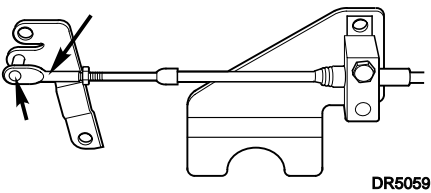

7. Install open end of trunnion in anchor block. Install screw in anchor block and position throttle cable assembly in selected set of holes. Locknut must be against the anchor bracket, tighten it securely.

8. Throttle arm connector must have a minimum of 9 full turns or 1/4 in. (6,4 mm) of throttle cable thread engagement. Install throttle arm connector onto the throttle cable. Pull connector forward to remove all end play from throttle cable, then turn the connector in until hole aligns with the "push-to-close" or "pull-to-close" throttle arm stud.

**NOTE! If throttle arm connector hole cannot be adjusted to align with the throttle arm, check for proper cable installation in the remote control box.**

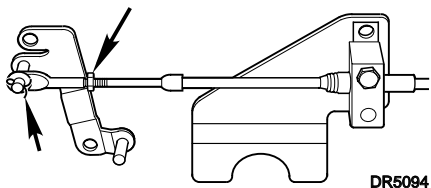

9. Install connector onto appropriate throttle arm stud. Install washer and cotter pin, and secure by spreading end of cotter pin. Tighten locknut against connector.

## Neutral Start Switch Tests

### Electrical

1. All switches must be in the "OFF" position, then disconnect battery cables at the battery before servicing electrical systems. Failure to do so could result in injury from:
  - shorted battery positive (B+), causing a burn or an electrical fire.
  - contact with moving parts, if the engine is accidentally cranked or started.
2. Move the control handle to the NEUTRAL position. Disconnect the yellow/red lead from the key switch and the yellow/red lead from the instrument wiring harness.
3. To test the continuity, calibrate an ohmmeter on high ohms scale. Connect the ohmmeter to the two leads. The meter should read zero (0).
4. Move the remote control handle to the FORWARD gear position. The meter should read infinity ( $\infty$ ). Move the remote control handle to the REVERSE gear position. The meter should read infinity ( $\infty$ ).
5. If the meter does not show ( $\infty$ ), check the ohmmeter connections and test again. Replace the neutral start switch if the meter still fails to show ( $\infty$ ) when the remote control handle is in the FORWARD and REVERSE gear position. Refer to the procedures in Disassembly of Remote Control to replace the neutral safety switch.

### Mechanical

1. With the boat in water and the remote control in NEUTRAL, turn the ignition key to the start position. The engine should start.
2. Disengage the remote control handle and move it into the FORWARD warm-up position. The engine should start.
3. Disengage the remote control handle and move it into the REVERSE warm-up position. Again the engine should start. Move the remote control handle back into NEUTRAL.
4. Move the remote control handle to the FORWARD gear position. The engine should NOT start. Move the handle to the REVERSE gear position. Again the engine should NOT start.
5. If the engine starts when the remote control handle is in either the FORWARD or REVERSE gear position, replace the neutral start switch. Refer to the procedures in Disassembly of Remote Control to replace the neutral safety switch.

## Removal of SAE Remote Control Cables

**NOTE! Should it become necessary to remove or replace the remote control cables, the attachment at the engine and sterndrive is very important. Follow these steps for removal of remote control cables.**

Before beginning, shift remote control handle into NEUTRAL detent position; the propeller should rotate freely.

## Throttle Cable From Engine

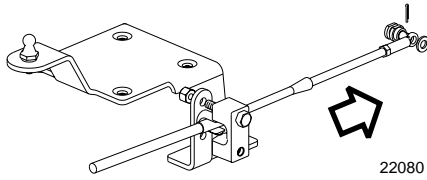

1. Remove cotter pin and flat washer from throttle arm.
2. Loosen anchor retainer nut and rotate retainer away from cable trunnion. Remove throttle cable from throttle arm and anchor bracket.

## Shift Cable From Sterndrive

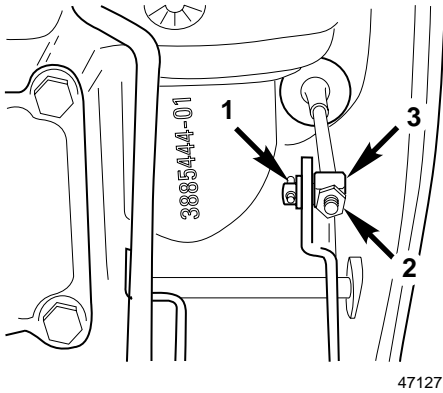

1. Remove drive's rear cover. Remove cotter pin (1) and flat washer from anchor pin (3). Remove jam nut (2) from shift cable core wire.

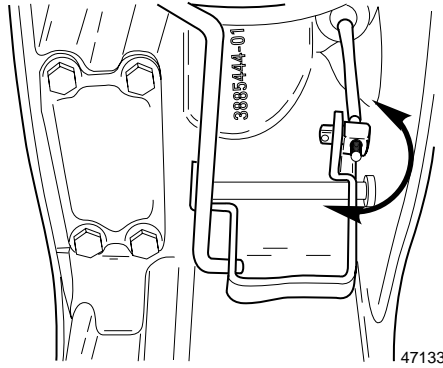

2. Remove anchor pin from bell crank slot. Unscrew anchor pin from shift cable core wire.

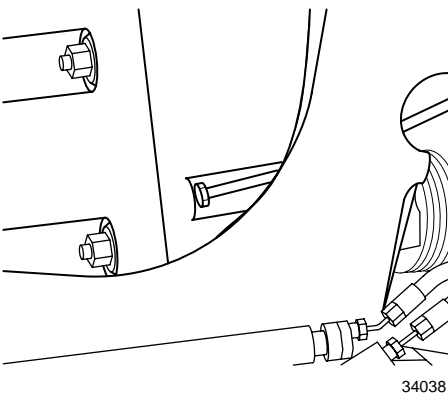

3. Loosen screw and slide retainer out of shift cable anchor groove. Pull the shift cable from drive and transom bracket cable tube.

## Section 6: Cooling System

|   |     |
|---|-----|
| Description .....   | 193 |
| Raw Water Cooled Engines .....  | 193 |
| Closed Cooling Engines .....  | 195 |
| Cooling System Troubleshooting .....  | 196 |
| Isolating Cooling Problem: .....  | 197 |
| Cooling System Components .....   | 198 |
| Hoses, Clamps, and Drain Plugs .....  | 198 |
| Thermostat .....  | 198 |
| Manifolds and Elbows .....  | 198 |
| Circulating Pump - Engine .....   | 198 |
| Supply Pump .....   | 199 |
| Impeller Removal .....  | 199 |
| Impeller Installation .....   | 201 |
| Draining Engine Block or Exhaust Manifold .....   | 202 |
| Draining Supply Pump .....  | 204 |
| Thermostat Replacement .....  | 204 |
| Sterndrive and Transom Bracket Cooling Schematic .....  | 207 |
| 5.0/5.7GL Engine Cooling Diagram .....  | 208 |
| 5.0GXi-A, 5.7Gi-A, 5.7GXi-A/B Cooling Diagram .....   | 209 |
| 5.0GXi-B/C/D/E, 5.0OSi-B/C/D/E, 5.7Gi-B/C/D/E, 5.7OSi-A/B/C/D,<br>5.7GXi-C/D/E/F, 5.7OSXi-A/B/C/D Cooling Diagram .....                           | 210 |
| 5.0GXi-BF/CF/DF/EF, 5.0OSi BF/CF/DF/EF, 5.7Gi-BF/CF/DF/EF,<br>5.7OSi-AF/BF/CF/DF, 5.7GXi-CF/DF/EF/FF 5.7OSXi-AF/BF/CF/DF<br>Cooling Diagram ..... | 211 |

### Description

#### Raw Water Cooled Engines

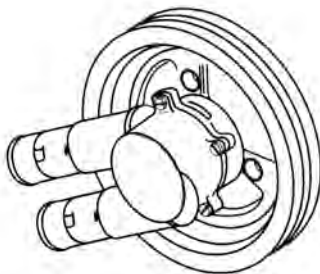

Raw water is supplied to the engine by means of an impeller type pump (raw water supply pump). The raw water supply pump is mounted on the engine crankshaft. Water supplied to the engine is circulated in the engine by means of a centrifugal type pump (circulating pump).

During low speed operation the impeller functions as a positive displacement pump. At higher speeds it functions as a combination centrifugal and positive displacement pump.

The shape of the housing and/or liner cause an eccentric action of the impeller blades during engine operation. During periods of high speed operation, the resistance of the water on its way through the pump is sufficient to prevent the ends of the impeller blades from making contact and following the inside perimeter of the pump housing. The

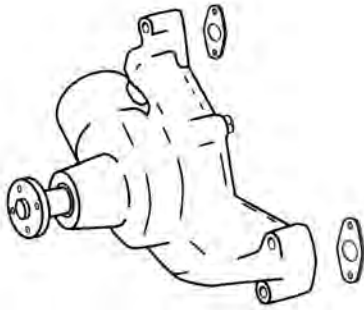

blades merely flex in toward the center of the impeller to perform as a combination centrifugal and positive displacement pump.

The circulating pump is mounted on the front of the cylinder block. It has a pulley bolted to the pump shaft hub at its forward end. This in turn is driven by means of a belt from the crankshaft pulley. The pump shaft and bearing assembly is pressed in the water pump housing. The bearing is permanently lubricated during manufacture and sealed to prevent loss of lubricant and entry of dirt. The pump is sealed against coolant leakage by a non-adjustable seal assembly pressed into the pump housing.

Cooling water for the engine is picked up at the water intakes on both sides of the lower gearcase. Water is pulled upward through the lower gearcase until it enters a water tube that transfers it to the upper gear housing.

Water is pulled through the upper gear housing water passage where it meets a nipple and hose attached to the pivot housing. Water is routed through the transom mount assembly to a tube that's mounted on the inside of the gimbal housing. From this tube the water is drawn through a supply hose that's connected to the inside nipple of the supply pump. Water exits the outside nipple of the supply pump under pressure and carried through a hose to the inlet nipple of the thermostat housing.

The water is now carried downward through the thermostat housing where it enters the flexible hose which attaches to the inlet pipe of the circulating pump. This inlet pipe is a part of the pump cover and feeds the coolant into a low pressure area located at the axis of the impeller. Vanes on the rotating impeller cause the coolant to be thrown outward and into the cylinder block.

The cooling water flows rearward through the water jacket which surrounds each cylinder and extends below the lower limit of piston ring travel. After flowing the full length of the cylinder block, the water is forced upward through two passages and into the cylinder head(s). The water now flows forward in the cylinder head(s) to cool the combustion chamber areas.

At the forward end of the cylinder head(s), the water enters the thermostat housing. If the water within the block is sufficiently warmed up, the thermostat will be open and a portion of the water will be pumped upward past the thermostat. The remainder will be returned via the flexible hose to the water pump for recirculation within the engine. The water which was pumped upward past the thermostat will enter the hose(s) connected to the thermostat housing outlet(s) and travel to the exhaust manifolds.

At this point the water flows rearward through the manifold passages and into the high-rise elbow. All of the water that enters the high-rise elbow is mixed with the exhaust gases prior to entering the exhaust pipe(s) and hose(s). This mixture of exhaust gases and water then enters the exhaust passages of the gimbal housing, pivot housing and sterndrive where it is discharged under water.



In the event the engine cooling water is cold, as in first starting up, the thermostat will be closed and will not allow any of the water to pass through for eventual discharge overboard. Instead, the water will be carried via the flexible hose back to the circulating pump for recirculation within the block. While the water within the block is recirculating, the supply pump is pumping water to the block.

Since this water is not able to enter the cylinder block, it is necessary to provide a method of discharge. This is provided by the bypass passage within the thermostat housing. If this were not provided, the resulting water pressure would be enough to force the thermostat off its seat, resulting in a greatly increased warm-up period.

## Closed Cooling Engines

The closed cooled engine is split into two halves by a heat exchanger, a raw water side and a closed cooled side of the heat exchanger. The heat exchanger transfers heat removed from the closed cooled side of the system to the raw water side which is pumped overboard through the exhaust.

### Raw Water Side

Raw water is supplied to the heat exchanger by means of an impeller type pump (raw water supply pump). The raw water supply pump is mounted on the engine crankshaft. During low speed operation the impeller functions as a positive displacement pump. At higher speeds it functions as a combination centrifugal and positive displacement pump. The shape of the housing and/or liner cause an eccentric action of the impeller blades during engine operation. During periods of high speed operation, the resistance of the water on its way through the pump is sufficient to prevent the ends of the impeller blades from making contact and following the inside perimeter of the pump housing. The blades merely flex in toward the center of the impeller to perform as a combination centrifugal and positive displacement pump.

Raw water for the heat exchanger is picked up at the water intakes on both sides of the lower gearcase. Water is pulled upward through the lower gearcase until it enters a water tube that transfers it to the upper gear housing.

Water from the raw water pump is supplied to the heat exchanger and is circulated through several channels inside the heat exchanger at which point it exits through flexible hoses to the exhaust manifolds.

At this point the water flows rearward through the exhaust manifold passages and up into the high-rise elbow. All of the water that enters the high-rise elbow is mixed with the exhaust gases prior to entering the exhaust pipe(s) and hose(s). This mixture of exhaust gases and water then enters the exhaust passages of the gimbal housing, pivot housing and sterndrive where it is discharged under water.

### Closed Cooling Side

The closed cooling side of the heat exchanger contains the water and antifreeze mixture and transfers engine heat from the coolant to the raw water circulated through the exchanger.

The closed cooling side of the heat exchanger flows through the engine circulation pump. The engine circulating pump is mounted on

the front of the cylinder block. It has a pulley bolted to the pump shaft hub at its forward end and is driven by a belt from the crankshaft pulley. The pump shaft and bearing assembly are pressed in the water pump housing. The bearing is permanently lubricated during manufacture and sealed to prevent loss of lubricant and entry of dirt. A non-adjustable seal assembly pressed into the pump housing seals the pump against coolant leakage.

The coolant flows rearward from the circulating pump through the cooling jacket, which surrounds each cylinder and extends below the lower limit of piston ring travel. After flowing the full length of the cylinder block, the coolant is forced upward through two passages and into the cylinder head(s). The water now flows forward in the cylinder head(s) to cool the combustion chamber areas.

At the forward end of the cylinder head(s), the coolant enters the intake manifold and the thermostat housing. If the coolant within the block is sufficiently warmed up, the thermostat will be open and a portion of the coolant will be pumped upward past the thermostat. The remainder will be returned via the flexible hose to the circulating pump for re-circulation within the engine. The coolant, which was pumped upward past the thermostat, will enter the Heat Exchanger to transfer engine heat to the raw water side of the cooling system. At this point the process starts over.

## Cooling System Troubleshooting

### Quiz Customer for the Following Information:

- a. How old is unit, how many hours of operation? (Wear and corrosion.)
- b. How long has problem existed? (Gradual or sudden.)
- c. What were the operating conditions prior to problem? (Fresh or salt water, silty or sandy water.)
- d. What previous repairs and service have been made on unit? (Tune-ups, impeller replacement, etc.)
- e. At what RPM does problem occur? (Low, high.)

### Possibilities To Consider:

- a. Temperature Gauge Malfunction.
  - Improper or defective sender unit
  - Malfunctioning gauge - Check ground wire - substitute good gauge.
- b. Engine Water Circulation Pump Malfunction.
  - Loose alternator belt
  - Impeller vanes worn - replace pump.
  - Impeller shaft seal failure - replace pump.
- c. Water Intake Screens Blocked.
- d. Ventilation - Marine growth on keel, hull deformities, etc.
- e. Ignition Timing
  - Running with retarded timing (carbureted engines only) - Check timing.

**Isolating Cooling Problem:****Air or exhaust gas entering cooling water:**

- a. **Procedure** - Replace water hose between thermostat housing and the supply pump with clear plastic hose. Operate unit in test tank or boat in water at RPM at which overheat occurs.

**NOTE!** If operating unit in test tank, run motor in neutral. Some test tanks may not have sufficient water volume to allow running engine in gear without creating turbulence. This can be picked up by the water intake and misconstrued as evidence of a cooling problem.

- b. **Results and Conclusions** - No bubbles in hose, air/ exhaust is not entering cooling water. Bubbles in hose, air/exhaust is entering cooling water.
- c. **Check for** - Defective lower gearcase water tube guide and seals; damaged water tube grommet; leaking water passage cover gasket or adaptor-to-gear housing gasket.

**Insufficient water supply:**

- a. **Procedure** - Disconnect water supply hose from transom bracket at thermostat housing. Operate engine at specified idle RPM. Hold end of hose level with the top of the flame arrestor.
- b. **Results and Conclusions** - A 1 inch (2,5 cm) head of water discharge, water supply is good. If less than 1/2 inch (1.2 cm), look for source of water loss.
- c. **Check for** - Blocked intake screens; damaged impeller housing O-ring or impeller plate gasket; broken or worn impeller; defective pivot housing water passage O-ring or water drain screw seal; loose pivot housing-to-gimbal housing water hose clamps.

**Thermostat malfunction**

- a. **Procedure** - Operate engine until indicated temperature exceeds 160°F (71° C). Touch hoses between thermostat and exhaust manifolds.
- b. **Results and Conclusions** - Hoses cold, thermostat is stuck closed. Hoses warm or hot, thermostat is good.
- c. **Check for** - Thermostat stuck open or closed, defective thermostat O-ring, correct thermostat style for engine type, clear thermostat housing bypass passage.

**Engine head gasket leakage**

- a. **Procedure** - Allow engine to cool. Replace water hose(s) between thermostat housing and exhaust manifolds) with clear plastic hose. Operate unit at RPM at which overheat occurs.
- b. **Results and Conclusions** - No bubbles evident, head gaskets not leaking. Bubbles evident, head gaskets leaking.
- c. **Check for** - Cylinder compression using appropriate tester, water in engine oil, water in cylinders, spark plugs wet with water.

## Cooling System Components

### Hoses, Clamps, and Drain Plugs

No special tools required.

**Inspection Procedure:** Examine all external cooling system components for leaks, wear, deterioration, and damage. Check all connections for tightness. Inspect hoses for cracks, checking or deterioration.

**Repair Procedure:** Repair or replace as required.

Water supply hoses used for replacement must conform to S.A.E. 20R3, class D-2.

### Thermostat

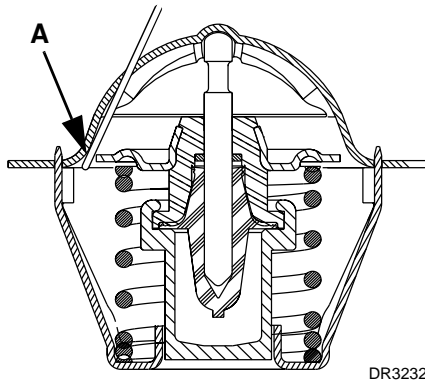

A 160° F (71° C) thermostat is standard.

**Inspection Procedure:** Check for proper rating and style, corrosion, restricted movement, or broken spring.

**Test Procedure** - Immerse the thermostat and a thermometer in a container of water. Heat water. Thermostat should start to open between 157-163° F (70-73° C), and should open to 5/32 in. (3,96 mm) minimum (A) at 182° F (83° C).

**Repair Procedure:** None, replace unit.

### Manifolds and Elbows

No special tools required.

**Inspection Procedure:** Pressure check components for leaks. Disassemble and inspect for corrosion or accumulation of foreign material.

**Repair Procedure:** Rod out any accumulation of foreign matter built up in water passages. If evidence of porosity between water passages and exhaust chambers or exterior is found, replace component. Install new gaskets on reassembly.

### Circulating Pump - Engine

No special tools required.

**Inspection Procedure:** Make sure belt tension is correct. With the engine running, observe the rotation of the circulating pump pulley. If the pulley does not run true it can cause excessive drive belt wear and damage to the circulating pump itself.

If the leakage of water occurs at the circulating pump while the engine is in operation, the pump may be loosely mounted to the engine, the shaft seal in front of the pump may be bad, the backing plate gasket may be defective, or the circulating pump mounting gaskets are leaking.

If the above inspections do not detect any defect, the pump must be removed and inspected for internal corrosion, blockage, or damage. Inspect impeller for erosion.

**Repair Procedure:** None, replace the pump.

**NOTE! Volvo Penta marine engines have a special circulating water pump with stainless steel components and a special marine shaft seal assembly. Do not replace with an automotive water pump.**

## Supply Pump

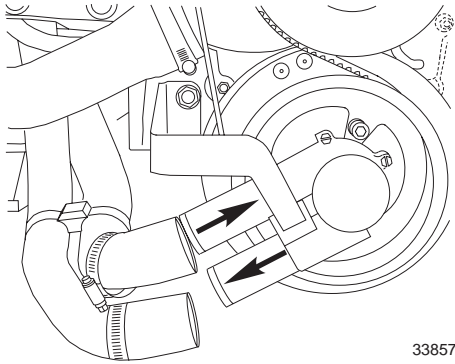

33857

## Removal

1. Drain engine, refer to Draining Engine Block or Exhaust Manifold on page 202.
2. Loosen hose clamps and remove hoses from supply pump. Note: The upper hose is the inlet hose.
3. Loosen bracket mounting screws and remove bracket.

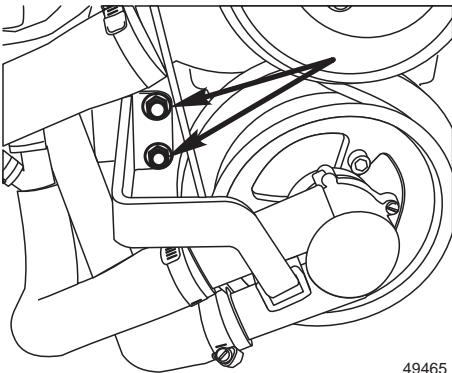

49465

## Impeller Removal

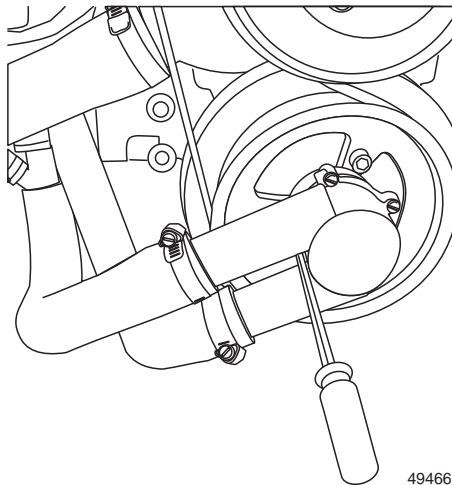

49466

1. Remove the four screws securing the housing.

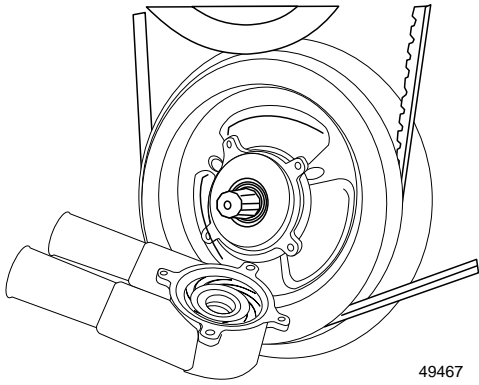

2. Remove pump housing.

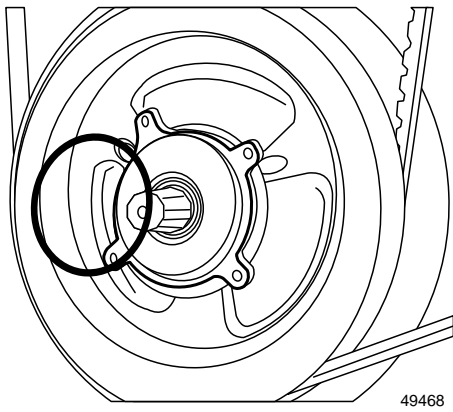

3. Remove and discard O-ring.

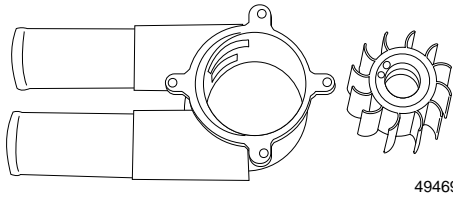

4. Grasp impeller securely and pull from housing.

### Cleaning and Inspection

1. Clean all parts with solvent and blow dry thoroughly.
2. Clean sealing surfaces.
3. Inspect impeller housing wear, and housing for cracks and distortion caused by freezing. Replace if necessary.
4. Inspect impeller; if blades are set in a bent position, cracked or broken, or show flat instead of rounded edges on the housing contact surfaces, replace the impeller.
5. Check bearings for smooth operation.

## Impeller Installation

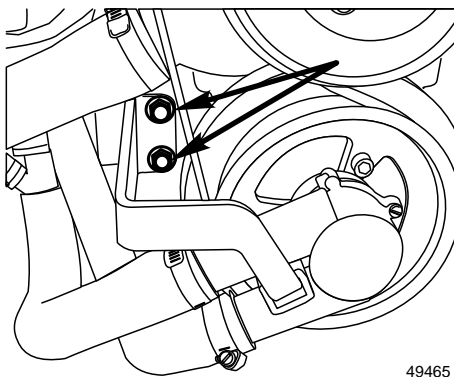
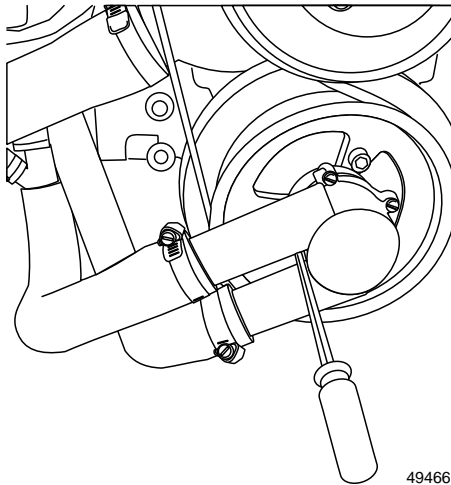
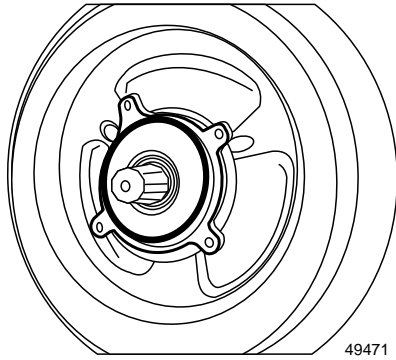
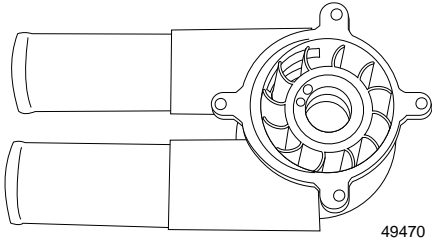

1. Apply a light coat of glycerine to impeller surfaces. Install impeller until seated in the housing.
2. Apply a light coat of Volvo Penta Grease to a new O-ring. Install the O-ring onto the pulley and shaft assembly.
3. Install pump and secure with four screws. Tighten screws to 19-24 in. lb. (2,2-2,8 N•m).
4. Orient pump assembly. Install bracket and secure with screws. Tighten screws to 20-25 ft. lb. (27-34 N•m).
5. Attach the inlet hose to upper nipple and the outlet hose to the lower nipple. Tighten hose clamps securely.

## Draining Engine Block or Exhaust Manifold

### 5.0GXi-A/B, 5.7Gi-A/B, 5.7GXi-B/C Draining the cooling system — raw water

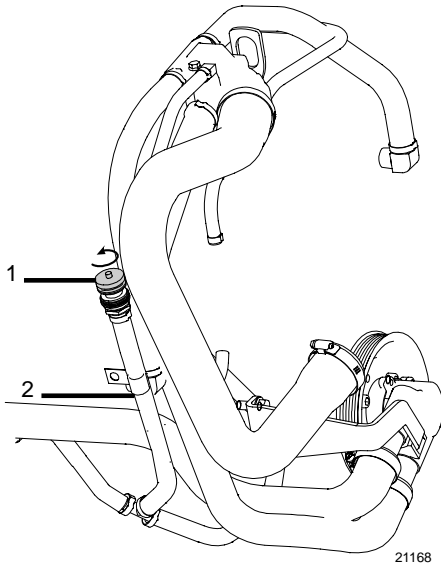

1. Locate the engine flush connector (1) at the front of the engine refer to features pages for location of flush adapter. Connect a garden hose to the connector with the supplied adapter.

**NOTE! The hose connection adapter supplied with the engine may not work in all geographic locations.**



**Caution!**

**Do not run the engine during the flushing procedure. Water is not supplied to the raw water pump and the pump impeller will be damaged.**

2. Turn the fresh water supply on and flush the engine with fresh water for 5 minutes to ensure the drain ports are open.
3. Turn off the fresh water supply and disconnect the garden hose from the engine flush connector. Lower the engine flush hose below the engine level and let drain.
4. After all of the water has drained out, reattach the hose cap and place back in original location.
5. Remove drain plugs from the exhaust manifold(s) and let drain completely. Reinstall the drain plug(s) and tighten.



**Caution!**

**If a garden hose with fresh water supply is unavailable, you must remove the hose nipple(s) from the engine to drain the engine block. To ensure all water is drained, clear the drain hole with a piece of wire. After the engine is drained reinstall the hose nipples and flush adapter as removed. The exhaust manifolds are drained as described previously**



5.0GXi-B/C/D/E, 5.0OSi-B/C/D/E,  
5.7Gi-B/C/D/E, 5.7OSi-A/B/C/D,  
5.7GXi-C/D/E, 5.7OSXi-A/B/C/D (F)-  
series (closed cooling)

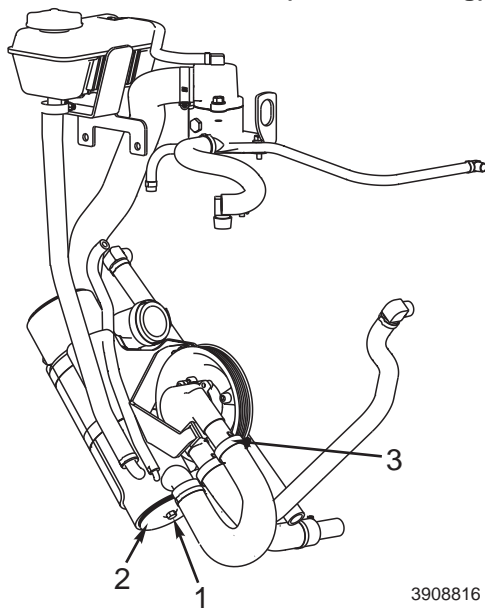

3908816

To drain the raw water side of the cooling system of your factory installed closed cooling on your Volvo Penta engine.



**Caution!** 5.0GXi-AF/BF/CF/DF/EF, 5.7Gi-AF/BF/CF/DF/EF, 5.7GXi-BF/CF/DF/EF/FF, OSi-AF/BF/CF/DF/EF, OSXi-AF/BF/CF/DF engines come factory filled with 50/50 coolant mixture of propylene glycol antifreeze and water. If the engine requires topping off, use only propylene glycol to refill the cooling system. Do not use Volvo Penta ethylene glycol in the cooling system.

If Volvo Penta antifreeze is preferred, you may use it provided the cooling system is drained and flushed before filling it with Volvo Penta antifreeze.

**Note!** The boat should be out of the water and the bow down slightly to allow complete drainage.

1. Using a 9/16 inch wrench, loosen but do not remove the cover bolt (1) on the bottom of the heat exchanger approximately three revolutions.
2. Twist the heat exchanger cover and gasket (2) in either direction and allow the water to completely drain from the system.
3. After the heat exchanger is drained, retighten the cover bolt to 27 N•m (20 lb. ft.)
4. Loosen the hose clamp (3) on the raw water inlet hose and remove the hose from the raw water pump.
5. Allow all the water to drain and reinstall the hose and tighten the hose clamp.



#### Caution

Ensure there is sufficient antifreeze in the closed side of the cooling system to protect the engine for the anticipated temperatures. Follow the antifreeze manufacturers instructions for proper water/antifreeze ratios.

5.0GXi-C/D/E, 5.0OSi-C/D/E, 5.7Gi-C/D/E,  
5.7OSi-B/C/D, 5.7GXi-D/E/F,  
5.7OSXi-B/C/D/E/F

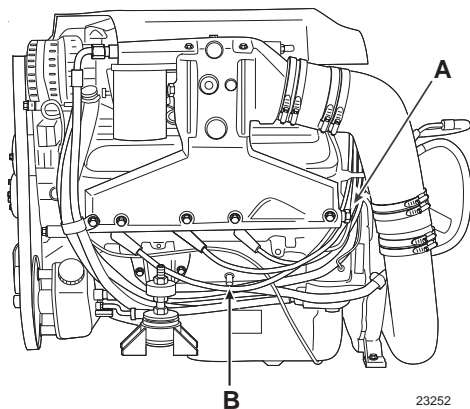

23252

1. With the engine turned off, locate and open the engine drain petcocks (B) located on both sides of the engine block.



#### Caution!

Be sure that all water is drained from the engine. If no water drains when the petcocks are opened, remove the petcocks and use a piece of wire to clear any obstructions from the drain hole. Failure to drain all the water from the engine may result in engine damage during freezing temperatures.

2. Remove drain plugs from exhaust manifolds (A). Raise or lower the bow of the boat to ensure complete drainage. After the water has completely drained, reinstall the drain plugs and torque to 29 N•m (22 lb. ft.).

- Note the hose orientation on the raw water pump. Loosen the hose clamps and remove the hoses from the raw water pump. Crank the engine briefly, (1 or 2 crankshaft revolutions) but do not start the engine, to clear the water from the pump. Reinstall the hoses and secure the clamps in the same orientation as removed.



### Caution!

**Failure to connect the raw water pump hoses in the correct orientation may damage the raw water pump impeller.**

### Draining Supply Pump

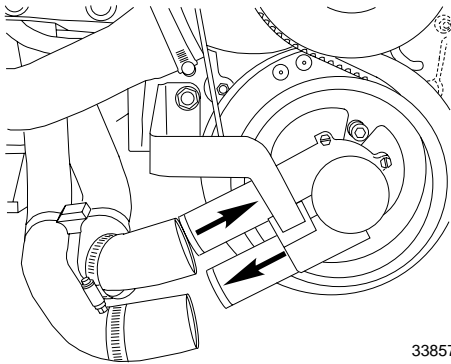

- Loosen and slide hose clamps back. Remove hoses from the pump and drain.
- Crank the engine no more than 2 seconds (DO NOT START) to expel any water trapped in water pump. Reattach hoses.

### Thermostat Replacement

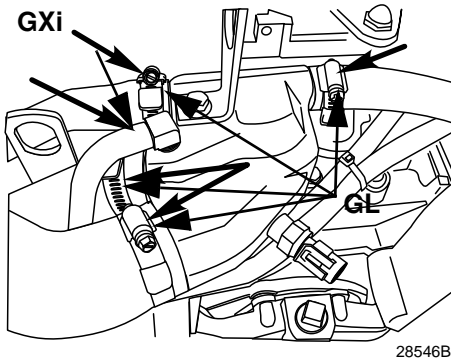

- Remove all water hoses from the thermostat housing.
  - GL Models: four hoses
  - Gi and GXi Models: same as GL plus one, five hoses

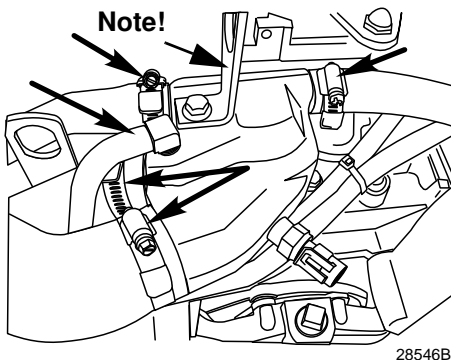

- Note position of lifting eye. Remove two screws then remove lifting eye and thermostat housing.

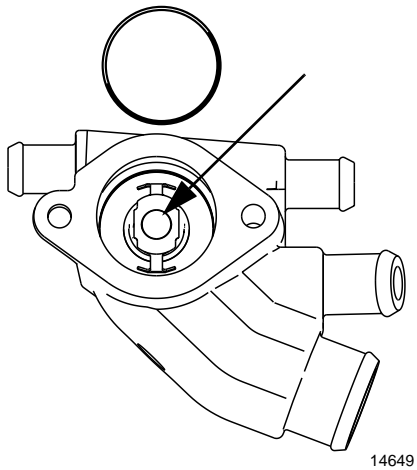

3. The thermostat is held in place by an O-ring. Pry the O-ring out of its groove, then lift the thermostat out of the housing.
4. Discard the housing gasket and O-ring. Thoroughly clean the housing and manifold gasket surfaces.
5. Place the thermostat in the housing. The temperature sensing element must face you when installed. Install a new O-ring to seal thermostat in housing. Make sure O-ring is completely seated in its groove.
6. Coat both sides of a new gasket with Volvo Penta Gasket Sealing Compound and place it on the manifold. Position thermostat housing and lifting eye on engine adapter as noted in Step 2. Install two lock washers and screws. Tighten the screws to 20-25 ft. lb. (27-34 N•m).
7. Connect the water supply hose to nipple and tighten hose clamp securely. Connect the three remaining water hoses and tighten hose clamps securely. Make sure lifting eye is positioned as shown.

**Caution!**

**If the water supply hose is attached to the wrong nipple, the engine will overheat.**

**Numbers refer to Cooling System Flow Diagrams.**

1. **Intake Screen** - Blocked with debris.
2. **Water Tube Guide and Seal** - Improperly sealed.
3. **Water Tube** - Plugged with debris.
4. **Grommet** - Deteriorated, improperly seated.
5. **Upper Gear Housing** - Debris blocking passage, freeze damaged.
6. **Pivot Housing Seal** - Damaged, out of position, improperly sealed.
7. **Nipple O-ring** - Out of position, improperly sealed, damaged.
8. **Nipple** - Blocked by debris, freeze cracked, loose in housing.
9. **Water Hose and Clamps** - Clamps loose, hose collapsed or leaking.
10. **Transom Mount Water Tube** - Blocked by debris.
11. **Supply Pump (Engine Mounted)** - Failed seal, corroded or bad bearings, eroded impeller, leaking mounting gaskets or backing plate.
12. **Thermostat Housing** - Corroded, restricted, or leaking gasket.
13. **Thermostat** - Defective thermostat, or wrong type for engine; improperly seated or damaged O-ring.
14. **Belts** - Loose, or worn and slipping.
15. **Circulating Pump (Engine)** - Failed seal, corroded or bad bearings, eroded impeller, leaking mounting gaskets or backing plate.
16. **Cylinder Block Water Passages** - Corrosion, slag, blocked passages, or leaking core plugs.
17. **Cylinder Head** - Corrosion, slag, blocked passages or leaking gaskets.
18. **Exhaust Manifold, Elbows, Gaskets, and Hoses** - Gaskets improperly installed; corrosion, sand, or slag in manifold and elbows; hoses collapsed, burned through, or leaking.
19. **Exhaust Pipe and Seal** - Improperly sealed or installed, leaking.
20. **Bellows, Clamp, and Retainer** - Loose clamp, detached or torn bellows.
21. **Power Steering Cooler** - Restricted, or cracked and leaking.
22. **Intake Manifold** - Cracked casting, or leaking gasket(s).
23. **Engine Oil Cooler** - Restricted, or cracked and leaking.

In addition, check:

- **Ignition Timing**
- **Boat Hull** - Condition of hull, marine growth, or under-hull equipment.

**Note!** **Fittings protruding through hull may cause air bubble streams which can be picked up by the lower gearcase and mixed with incoming cooling water to cause an overheat condition.**

### Sterndrive and Transom Bracket Cooling Schematic

- A) Water In
- B) To thermostat housing
- C) Return from exhaust pipe
- D) Exhaust and water out

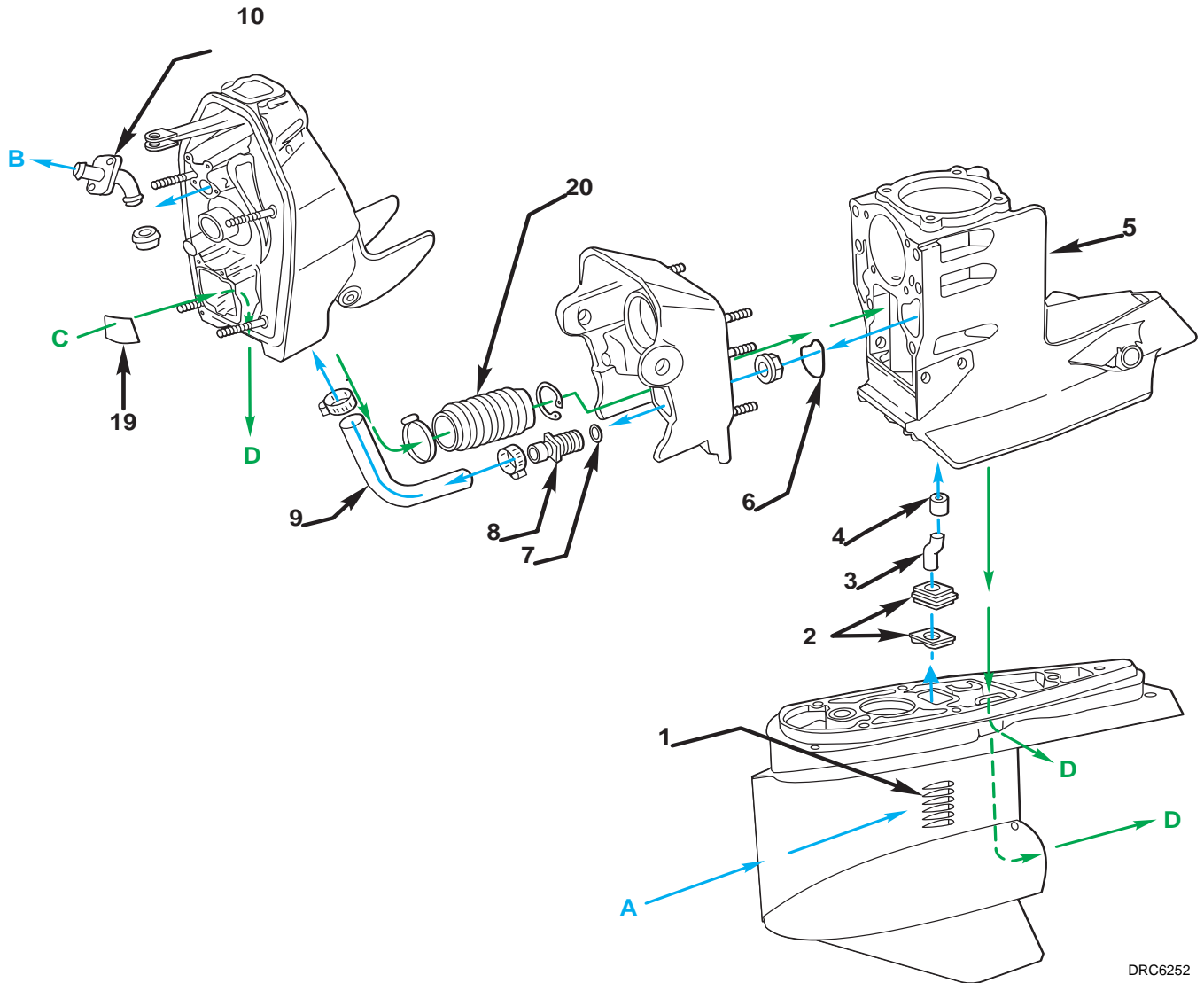

DRC6252

### 5.0/5.7GL Engine Cooling Diagram

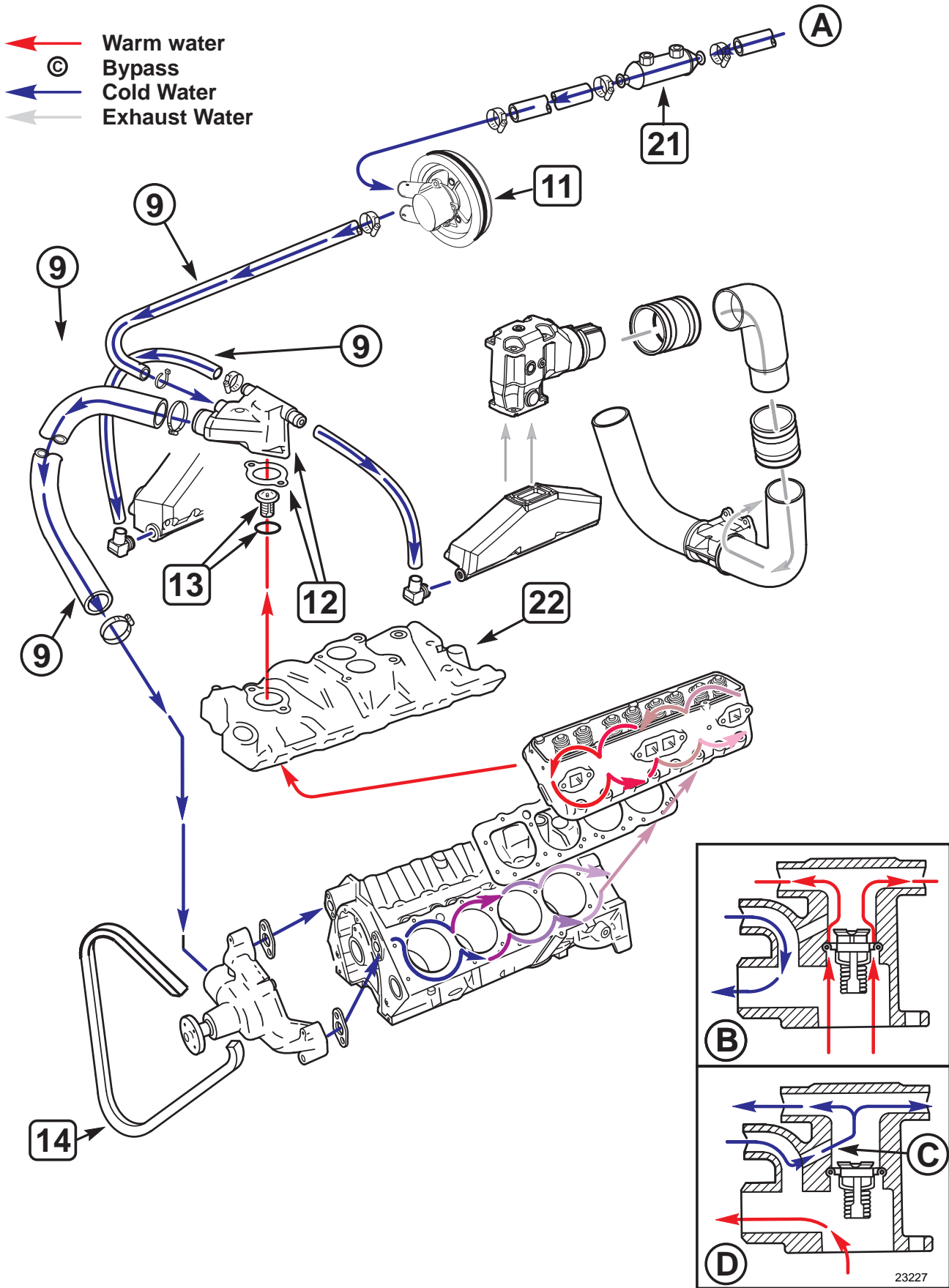

23227

23227

5.0GXi-A, 5.7Gi-A, 5.7GXi-A/B Cooling Diagram

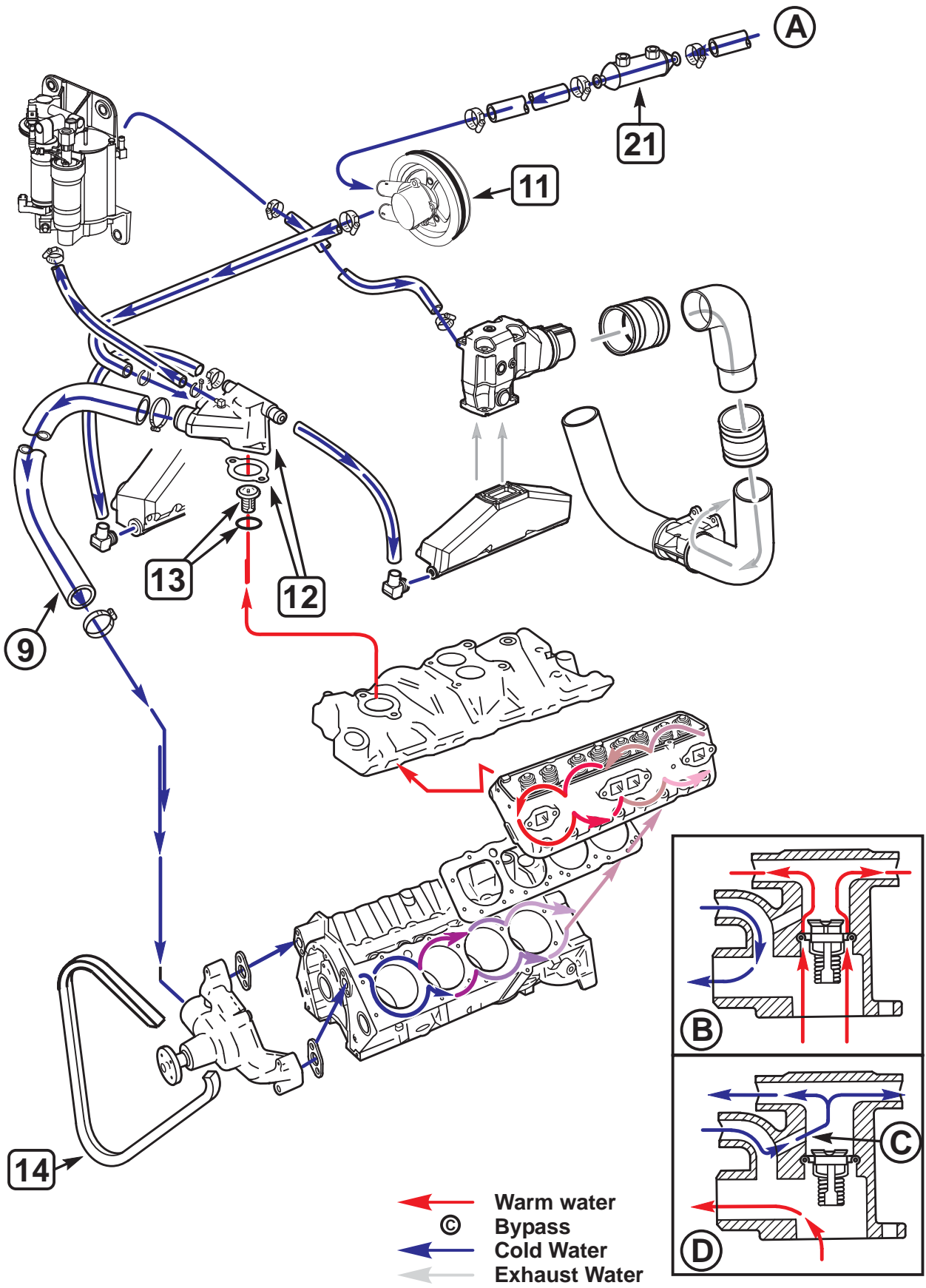



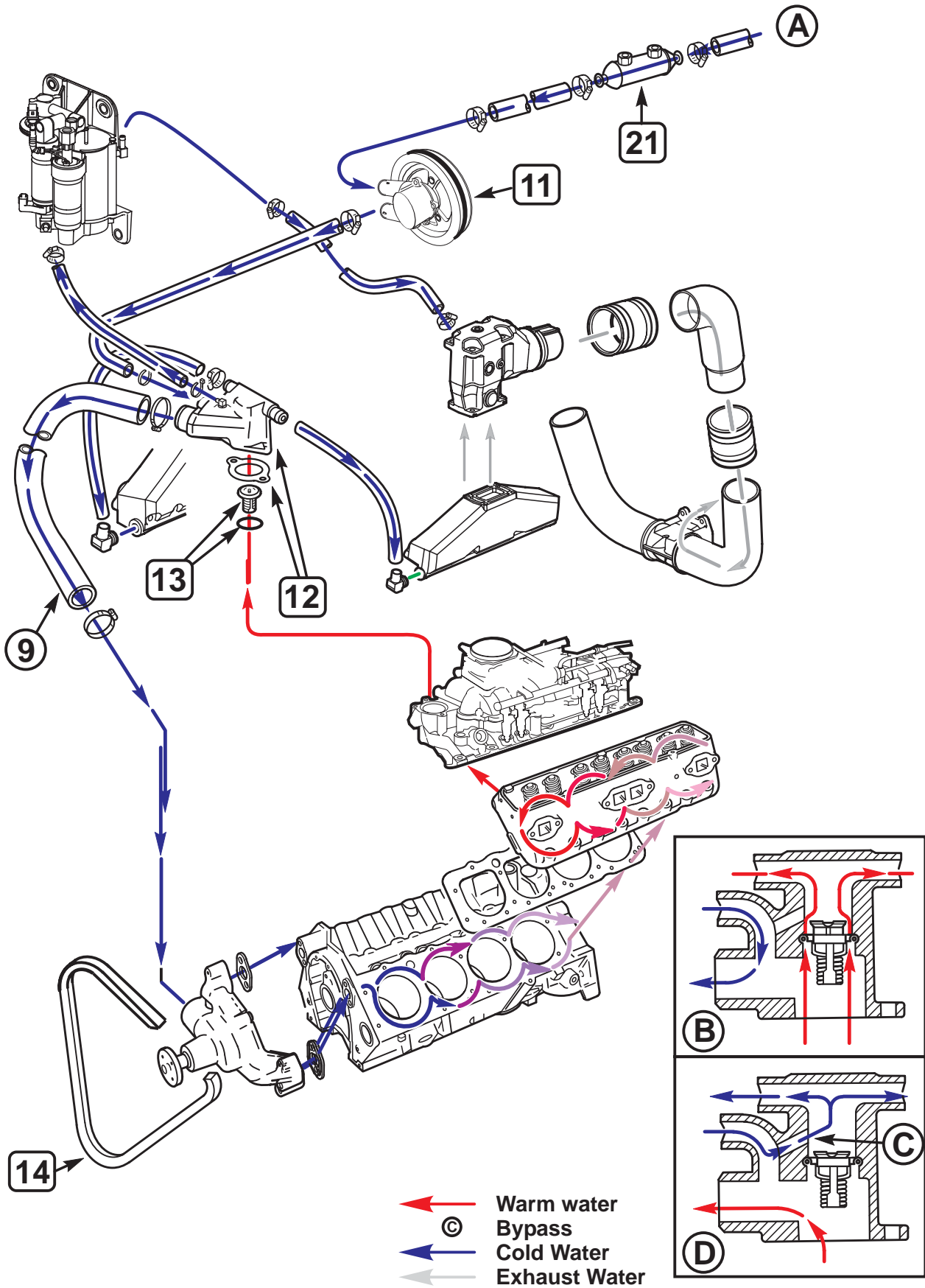



5.0GXi-B/C/D/E, 5.0OSi-B/C/D/E, 5.7Gi-B/C/D/E, 5.7OSi-A/B/C/D, 5.7GXi-C/D/E/  
F, 5.7OSXi-A/B/C/D Cooling Diagram





5.0GXi-BF/CF/DF/EF, 5.0OSi BF/CF/DF/EF, 5.7Gi-BF/CF/DF/EF, 5.7OSi-AF/BF/CF/DF, 5.7GXi-CF/DF/EF/FF 5.7OSXi-AF/BF/CF/DF Cooling Diagram

-  Warm water
-  Bypass
-  Cold Water
-  Exhaust Water
-  Raw Water
-  Air Vent

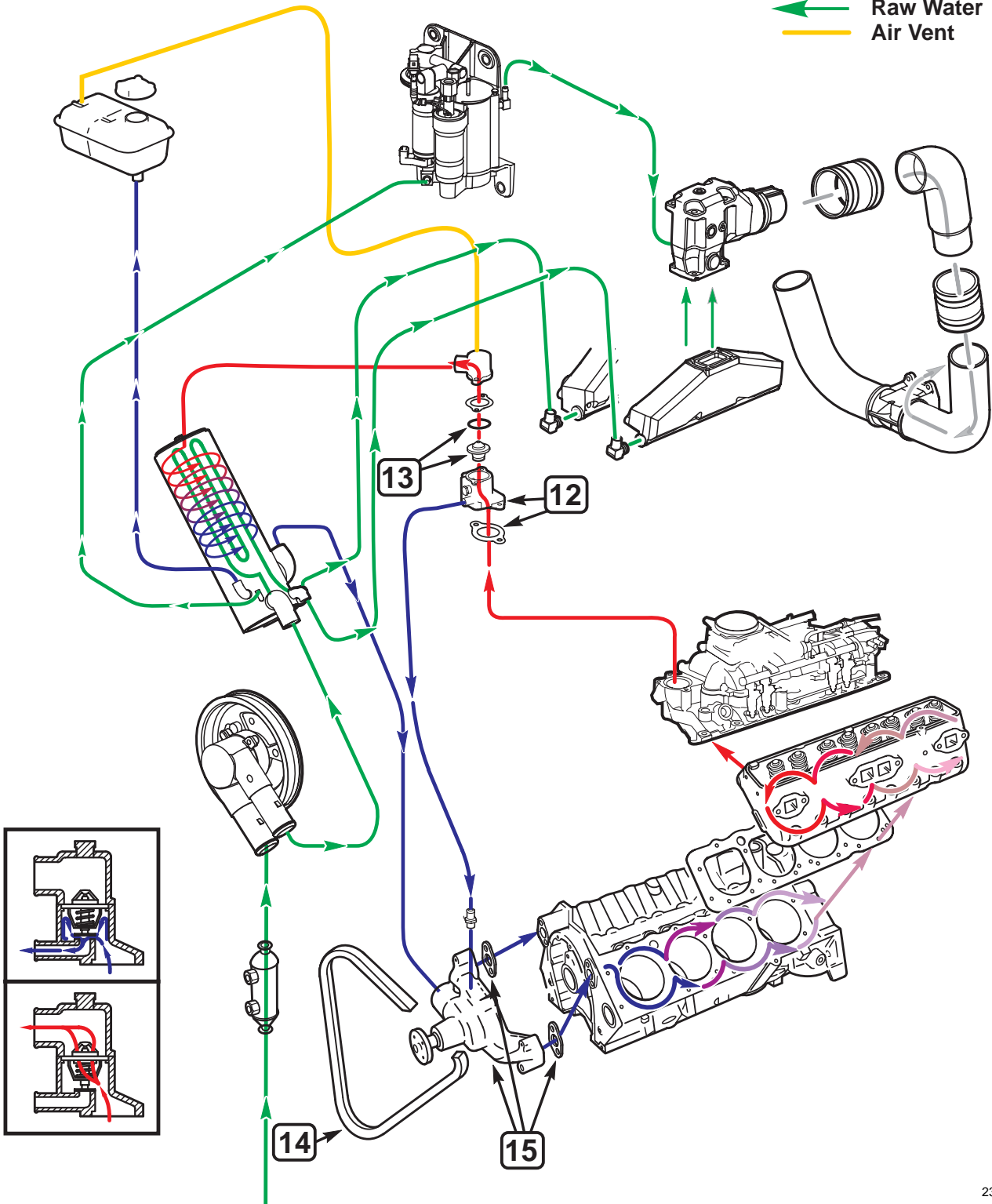

23223

# NOTES

A series of horizontal dashed lines for taking notes.

# Section 7: Engine Removal and Installation

- Special Tools ..... 213
- Sealants, Lubricants and Adhesives ..... 213
- Engine Removal ..... 213
- Exhaust Pipe Replacement ..... 217
- Engine Installation ..... 218
- Engine Alignment ..... 219
- Connect Exhaust Hose ..... 220
- Connect Throttle Cable ..... 220
- Connect Fuel Supply ..... 225
- Rear Engine Mounts ..... 225
- Determining Minimum Engine Height ..... 227



### Safety Warnings

**Before working on any part of the engine, read the Safety section at end of this manual.**

**Proper installation is important for the safe, reliable operation of all mechanical products. The procedures we recommend and describe in these instructions are effective methods to be followed when removing or installing the engine. Some of these methods require the use of tools specially designed for the purpose. The special tools should be used when and as recommended.**

### Special Tools

- Alignment Tool 3851083-0
- Universal Handle 3850609-3

### Sealants, Lubricants and Adhesives

- Volvo Penta Gasket Sealing Compound
- Volvo Penta Grease
- 3M Adhesive

## Engine Removal

**NOTE! Before removing engine, check engine height. See Determining Minimum Engine Height.**

Check engine clearance between front of engine and engine compartment bulkhead prior to starting work. If clearance is less than 6 in. (15,2 cm), the sterndrive must be removed to disengage U-joint shaft from engine coupler. See Sterndrive and Transom Bracket Service Manual.

When engine clearance is more than 6 in. (15.2 cm), the engine can be pulled forward to disengage the U-joint shaft from the flywheel coupler, and be removed from the engine compartment.

**NOTE!** The Sterndrive can remain installed only if engine removal does not require re-alignment of the engine. If the engine mounts, boat stringers, or engine coupler are being repaired or replaced, remove the sterndrive for engine alignment.



**Warning!**

To prevent possible fire and explosion caused by ignition of fuel vapors which may be present in the engine compartment, remove the positive and negative cables from the battery.

**Disconnect Battery**



**Caution!**

All switches must be in the “OFF” position prior to disconnecting the red (positive) and black (negative) cables from the battery. This will safeguard against permanent damage to electrical components.

**Disconnect Power Steering Lines**

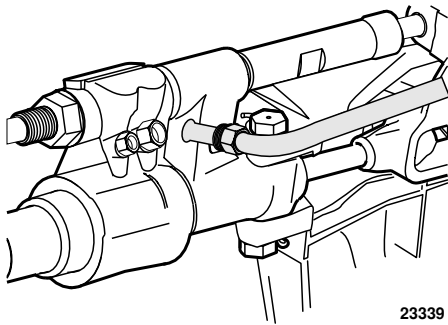

1. Disconnect both power steering lines at the steering cylinder.
2. Cover both steering cylinder openings and line fittings to prevent fluid loss and entry of contaminants. Tie lines onto engine higher than power steering pump to prevent damage and loss of oil during engine removal.

**Disconnect Fuel Supply**

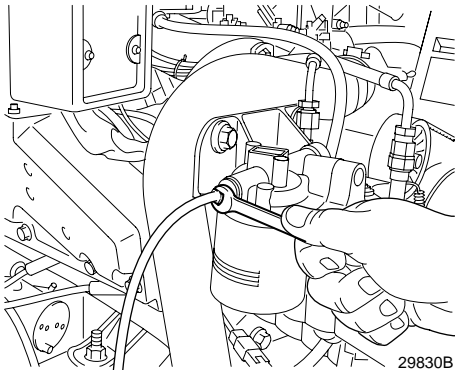

Disconnect boat fuel line at the fuel filter inlet. Seal end of fuel line and inlet opening.

### Disconnect Electrical Cables

1. Disconnect the plastic two-wire trim/tilt motor connector.

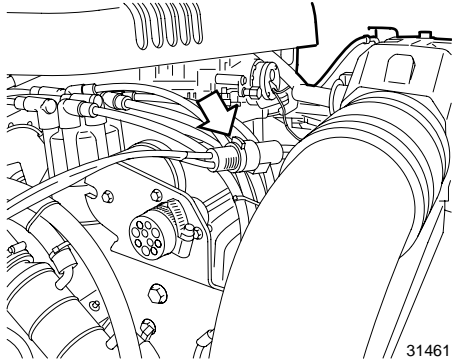

2. Remove wire retainer and unplug rubber two-wire trim/tilt sender connector. Cut tie strap securing sender cable, if required.

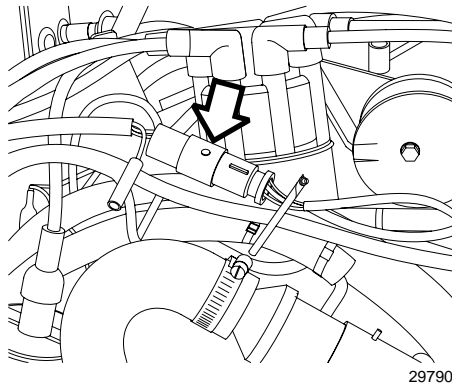

3. Unscrew worm clamp and disconnect large rubber instrument cable connector.

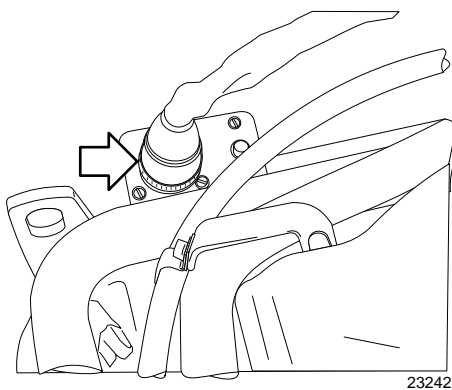
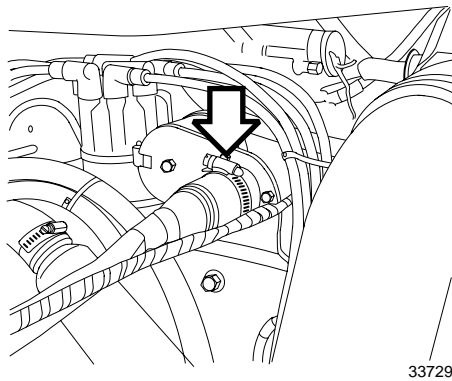

### Disconnect Throttle Cable

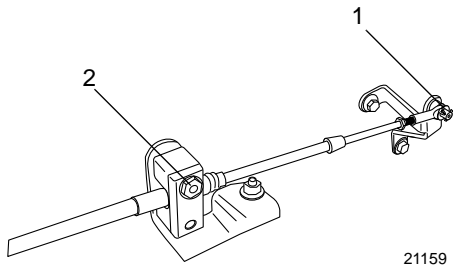

21159

1. Remove cotter pin and flat washer (1) from throttle arm.
2. Loosen anchor retainer nut and rotate retainer away from cable trunnion. Remove throttle cable from throttle arm and anchor bracket.

### Disconnect Exhaust Hose

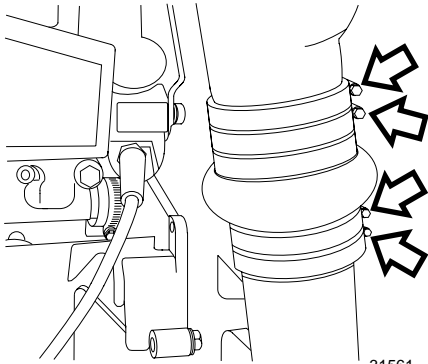

31561

1. Loosen four clamps on lower exhaust hose. For ease of moving lower hose, lubricate exhaust pipe.
2. To free lower hose from intermediate pipe, pry or twist hose. Slide hose down onto exhaust pipe.

### Disconnect Water Hose

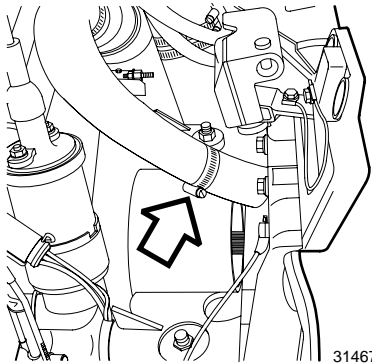

31467

Loosen clamp and pull water supply hose off transom bracket water tube.

### Separate Engine Mounts

1. Attach a hoist to lifting brackets of engine. Hoist must have a lifting capacity of at least 1500 lb. (680 kg).

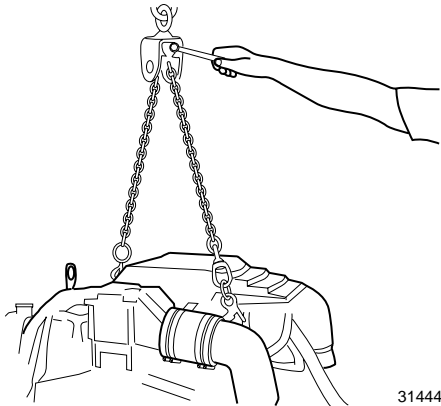

2. Remove and retain both lock nuts (1) and both flat washers (2) from rear engine mounts.

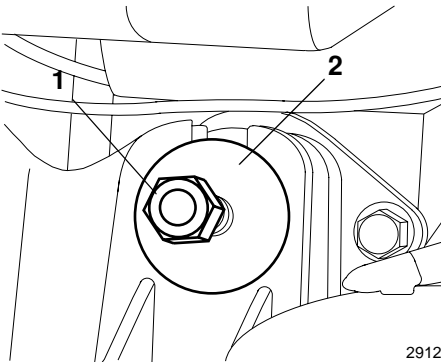

3. Remove and retain lag screws from front engine mounts.

If sterndrive was removed, lift engine out of engine compartment. If sterndrive was not removed, lift engine slightly and pull it forward to disengage U-joint shaft and flywheel coupler. With U-joint shaft clear of flywheel coupler, lift engine out of compartment.

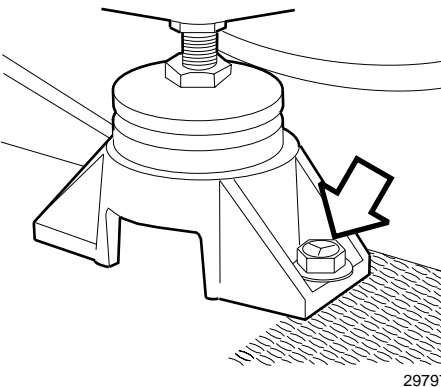

### Exhaust Pipe Replacement

- Removal**
1. Remove engine following previous procedure.

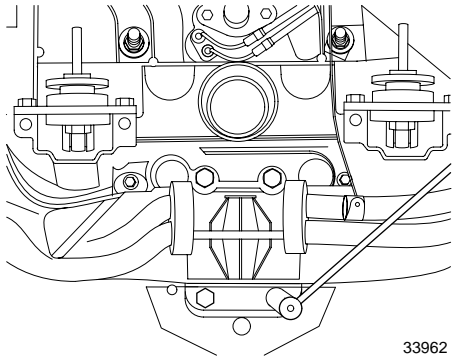

2. Remove and retain four exhaust pipe screws. Remove exhaust pipe and discard seal. Clean all material from transom bracket and exhaust pipe seal surfaces.

Exhaust pipe mounting holes have locking Heli-Coil® inserts. Do not clean screw holes with a thread tapping tool, otherwise locking feature will be destroyed and Heli-Coil will have to be replaced.

### Installation

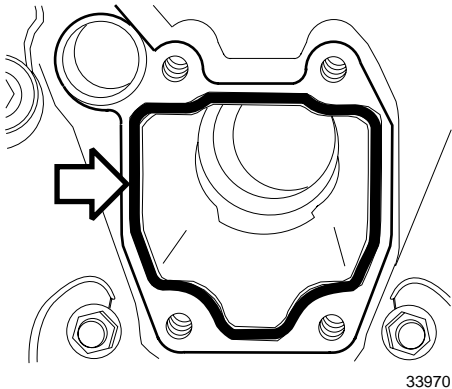

1. Coat a new seal with 3M Scotch Grip Rubber Adhesive 1300 and place in transom bracket groove.
2. Apply Volvo Penta Gasket Sealing Compound to the four exhaust pipe mounting screws.

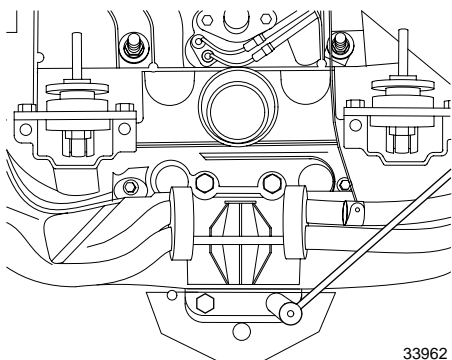

3. Secure exhaust pipe to transom bracket with four screws. Tighten to 20-25 ft. lb. (27-34 N•m). Slide exhaust hoses and clamps onto exhaust pipes if they were removed.
4. Install engine.

### Engine Installation

#### Attach Engine Mount

1. Lower engine into engine compartment:
  - If sterndrive was not removed, and engine crankshaft was not rotated, engage U-joint shaft with engine coupler and slide engine back onto rear mounts. If coupler and U-joint shaft will not align, either the engine or U-joint shaft will have to be rotated to allow engagement. If engine mount height was disturbed, engine must be realigned as described later.
  - If sterndrive has been removed, lower engine onto rear mounts.



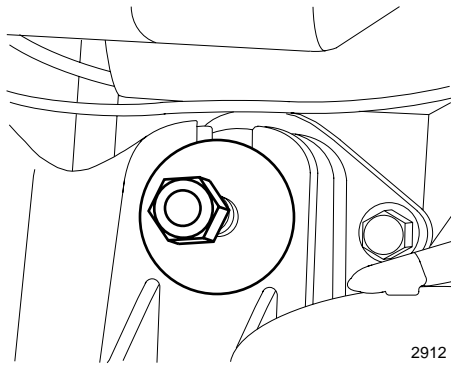

2. Install flat washers into recesses of engine bracket and secure engine to mount with lock nuts. Tighten lock nuts to 28-30 ft. lb. (38-40 N•m).



**Caution!**

**Do not use an impact wrench or power driving tool to install the lock nuts onto the studs.**

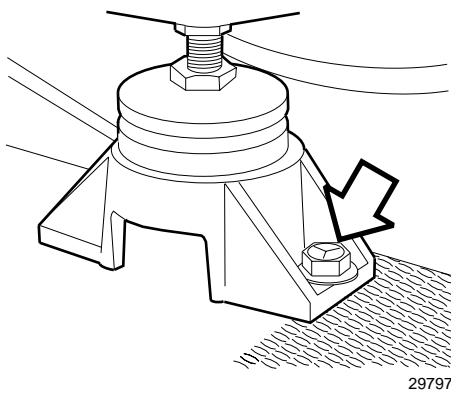

3. Install forward engine mount lag screws and tighten them securely.

If sterndrive was not removed, go on to Exhaust Hose Attachment. If sterndrive was removed, continue with Engine Alignment section.

**Engine Alignment**

**NOTE! Correct engine alignment is essential to long engine drive-train life. The front engine mounts may need adjustment UP or DOWN to produce correct engine alignment. Use Alignment Tool, Volvo Penta P/N 3851083-0, with Universal Handle, Volvo Penta P/N 3850609-31, to check engine alignment.**

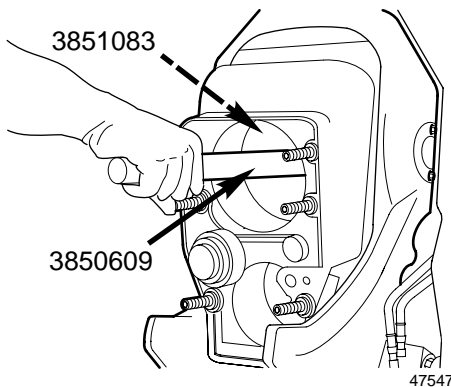

1. Slide alignment tool through driveshaft gimbal bearing. The alignment tool must slide through the gimbal bearing and into engine coupler with ease. If the alignment tool binds going into engine coupler, make sure the gimbal bearing is properly aligned. If gimbal bearing alignment is correct, the front engine mounts must be adjusted either UP or DOWN, as required, until alignment tool slides easily in and out of engine coupler.

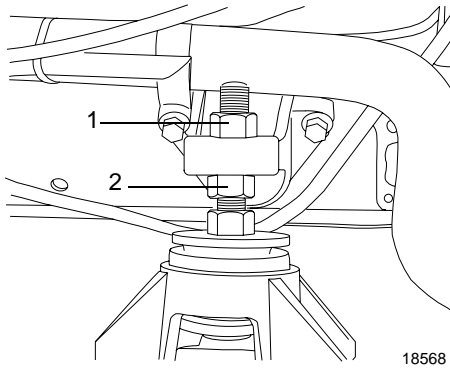

2. To change engine height, tighten or loosen nuts (1) and (2) as required. See respective engine section, Front Mount Height Adjustment.
3. After correct alignment has been made, the front mount(s) must be tightened to maintain alignment.
  - While holding one nut with an open-end wrench, tighten the second adjusting nut to 100-120 ft. lb. (136-163 N•m).

### Connect Exhaust Hose

Push lower hoses up onto intermediate exhaust pipes.

Position and tighten all hose clamps securely between ribs of exhaust hose(s) as shown.

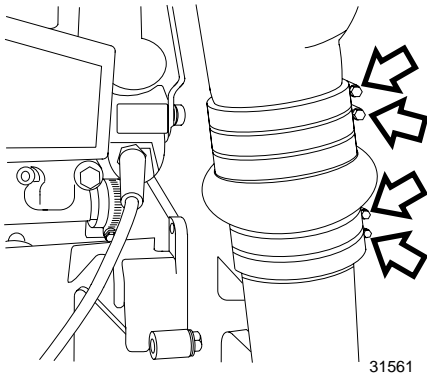

#### Caution!

**DO NOT** install hose clamps in expanded area of hose(s).  
Cooling will be restricted and engine damage will occur.

### Connect Throttle Cable

**NOTE!** Position remote control handle in **NEUTRAL**, propeller should rotate freely. Turn propeller shaft and shift into the forward gear detent position, then pull handle **HALFWAY BACK** towards **NEUTRAL**. This positions the control for proper throttle adjustment. Failure to follow this procedure can result in “hard shifting” into gear.

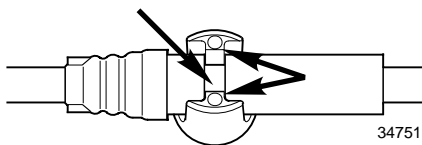

1. Align internal bosses of trunnion with throttle cable groove. Press trunnion on throttle cable until seated.

**Carbureted Models Only**

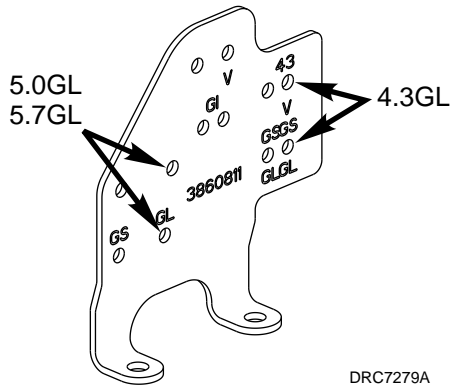

DRC7279A

2. GL and Models: The engine throttle cable anchor block bracket has several sets of anchor block holes. The sets of holes marked with a "V" are used for Volvo Penta engines. The set of holes marked "43" are for 4.3 GL models. Holes marked GL are for all 5.0 and 5.7 Liter, carburetor models.

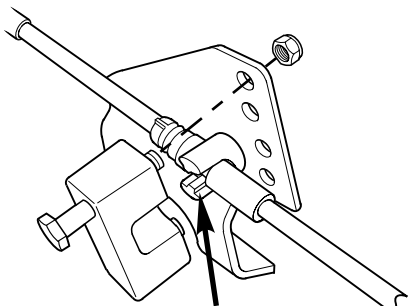

DR4977

3. Install open end of trunnion in anchor block. Install screw in anchor block and position throttle cable assembly in selected set of holes. Nut must be against the anchor bracket, tighten it securely.

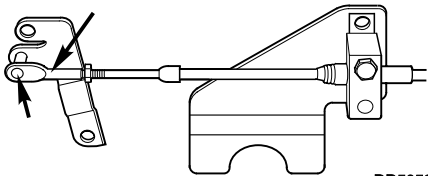

DR5059

4. Throttle arm connector must have a minimum of 9 full turns or 1/4 in. (6 mm) of throttle cable thread engagement. Install throttle arm connector onto the throttle cable. Pull connector forward to remove all end play from throttle cable, then turn the connector in until hole aligns with the throttle arm stud.

**NOTE! If throttle arm connector hole cannot be adjusted to align with the throttle arm, check for proper cable installation in the remote control box.**

5. Install connector onto throttle arm. Install washer and cotter pin, and spread cotter pin prongs. Tighten jam nut against connector.

For throttle and shift cable adjustment procedures, See "Installation of Shift and Throttle Cables" on page 195.

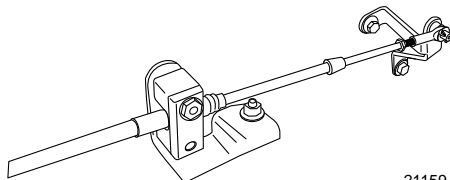

21159

### Connect Water Hose

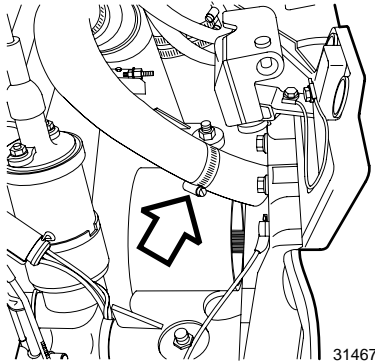

1. Slide hose clamp onto water inlet hose. Lightly lubricate inside of water inlet hose and push hose onto water inlet tube.

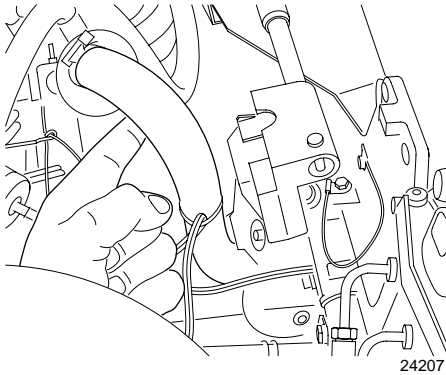

2. If inlet hose is not installed properly, underside of hose may collapse. Check underside of hose for proper installation and adjust hose as required. Tighten hose clamp securely.

**NOTE! Failure to install water inlet hose correctly can result in powerhead damage from blockage of water circulation.**

### Connect Power Steering Lines

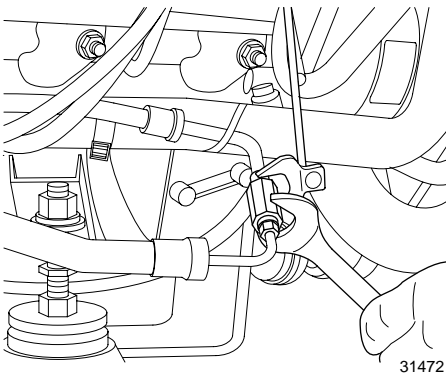

1. Remove tape or protective cover from small hydraulic hose fitting (or unscrew steering line connector) and small steering cylinder opening.

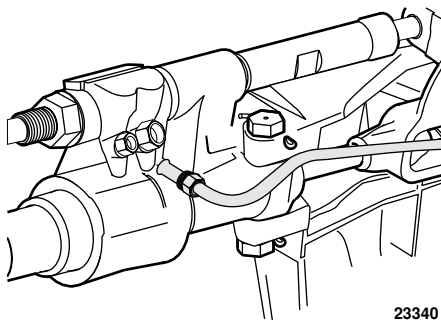

2. Install small hose fitting into steering cylinder.

3. Install large hose fitting into steering cylinder.

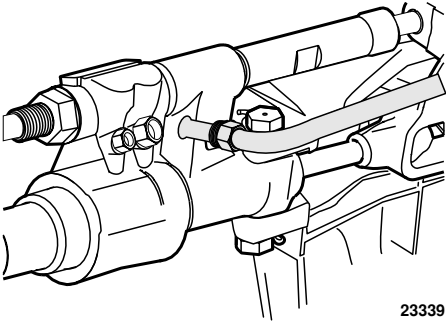

4. Tighten small hose fitting to 10-12 ft. lb. (14-16 N•m).

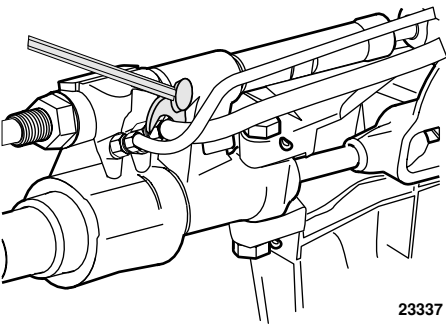

5. Tighten large hose fitting to 15-17 ft.lb. (20-23 N•m).

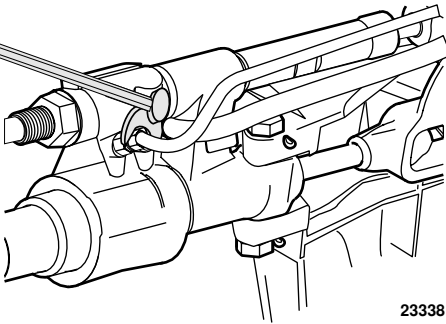

### Connect Electrical Cables

6. Connect plastic two-wire plug of engine harness to two-wire receptacle of trim/tilt motor. Connectors should lock together. Route trim/tilt cable behind shift bracket.

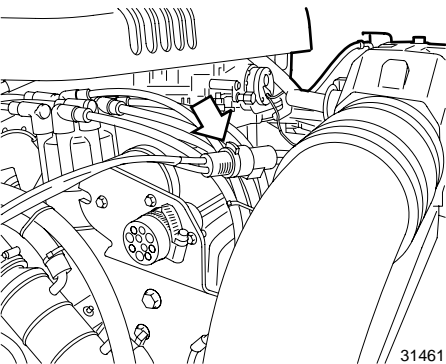

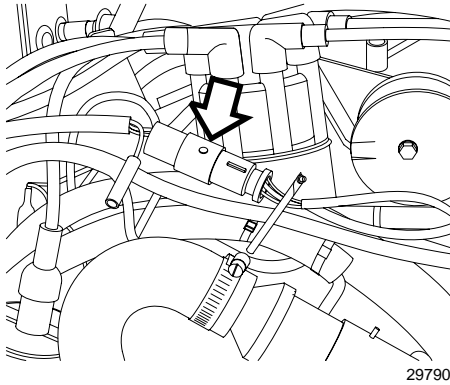

7. Connect rubber two-wire trim/tilt sender plug to two-wire receptacle of instrument harness. Secure connectors with wire retainer and cable with a tie strap.

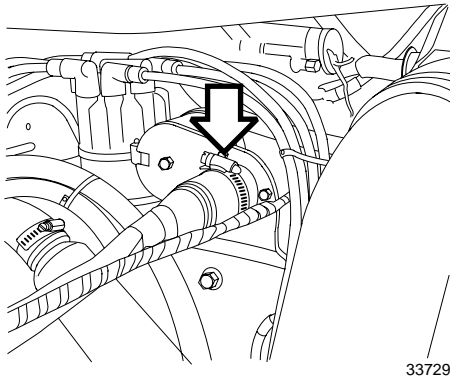

8. Route the instrument cable plug to join engine cable receptacle on engine.



### Warning!

**Ensure cable is routed to prevent cutting or chafing on any sharp or hot object. This could result in an electrical short, and contribute to fire and explosion in the engine compartment.**

9. Apply a light coat of Volvo Penta Grease grease around large engine plug.
10. Slide hose clamp over large engine receptacle. Align the two large terminals on plug and receptacle and press together. Slide hose clamp over receptacle and tighten securely.
11. **All switches must be in the "OFF" position prior to connecting battery cables to the battery.** Be sure polarity is observed; positive (+) cable to the positive terminal, and negative (-) cable to the negative terminal.

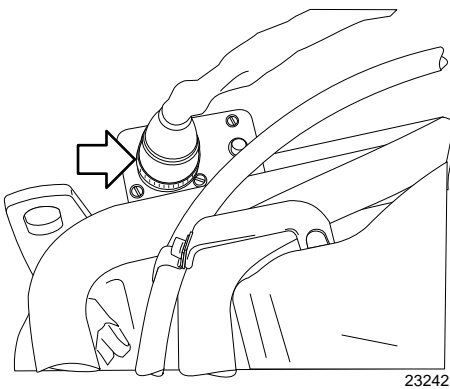

### Connect Fuel Supply

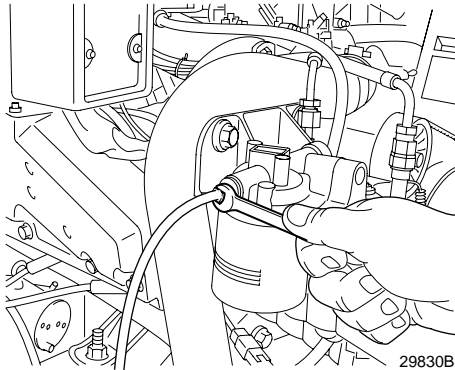

12. Attach boat's fuel supply hose to fuel filter canister. On EFI models connect to the Fuel Cell. Tighten connection securely. Check for fuel leaks when testing engine, and repair any leaks that might occur.

### Rear Engine Mounts

#### Removal

1. Remove engine See "Engine Removal" on page 213.
2. Unscrew two screws and washers, then lift mount assembly off transom plate.



#### Disassembly



1. Hold square nut and remove screw. Mount assembly will break down into components shown. Pay particular attention to the two mount washers; their thickness, shape (concave or flat), and position in the assembly (above or below the rubber mount).

#### Assembly

1. Slide lower washer onto mount bolt; make sure you choose the correct washer (as determined during the mount disassembly) for this position. Insert bolt into bottom (flat) side of rubber mount assembly, and install remaining washer and square nut. Do not tighten nut at this time.

**NOTE!** If top and bottom washers are not installed in their original positions, mount may transmit excessive engine vibrations into boat and cause undesirable operating conditions.

2. Turn mount assembly upside down and clamp square nut in vise. Rotate rubber mount until mounting holes are positioned at 90° to any side of square nut. Hold mount in this position and tighten center bolt to 44-52 ft. lb. (60-71 N•m).

**NOTE!** If 90° relationship between nut and mounting holes is not maintained, slot of engine mount pad cannot engage rear mount during installation.

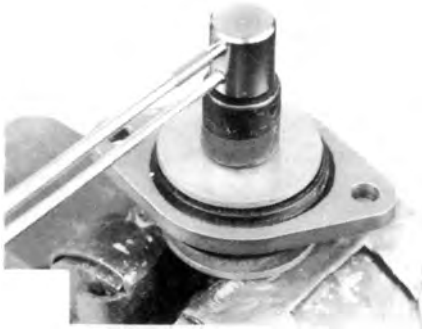

6680

### Installation

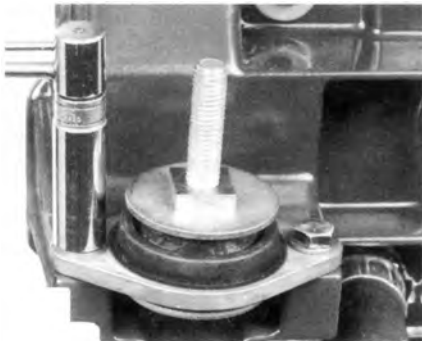

6677

1. Place mount assembly on transom plate. Install two screws and washers, and tighten them to 20-25 ft. lb. (27-34 N•m).

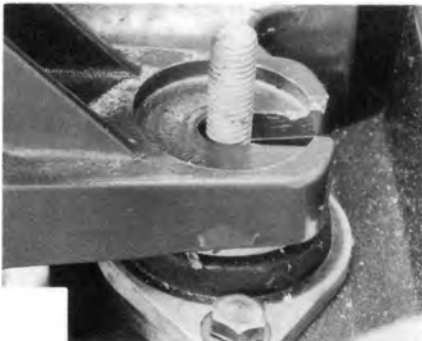

12212

2. Install engine See "Engine Installation" on page 218. Make sure mount pad slot engages square nut. Install both flat washers and locknuts, then tighten locknuts to 28-30 ft. lb. (38-41 N•m).



## Determining Minimum Engine Height

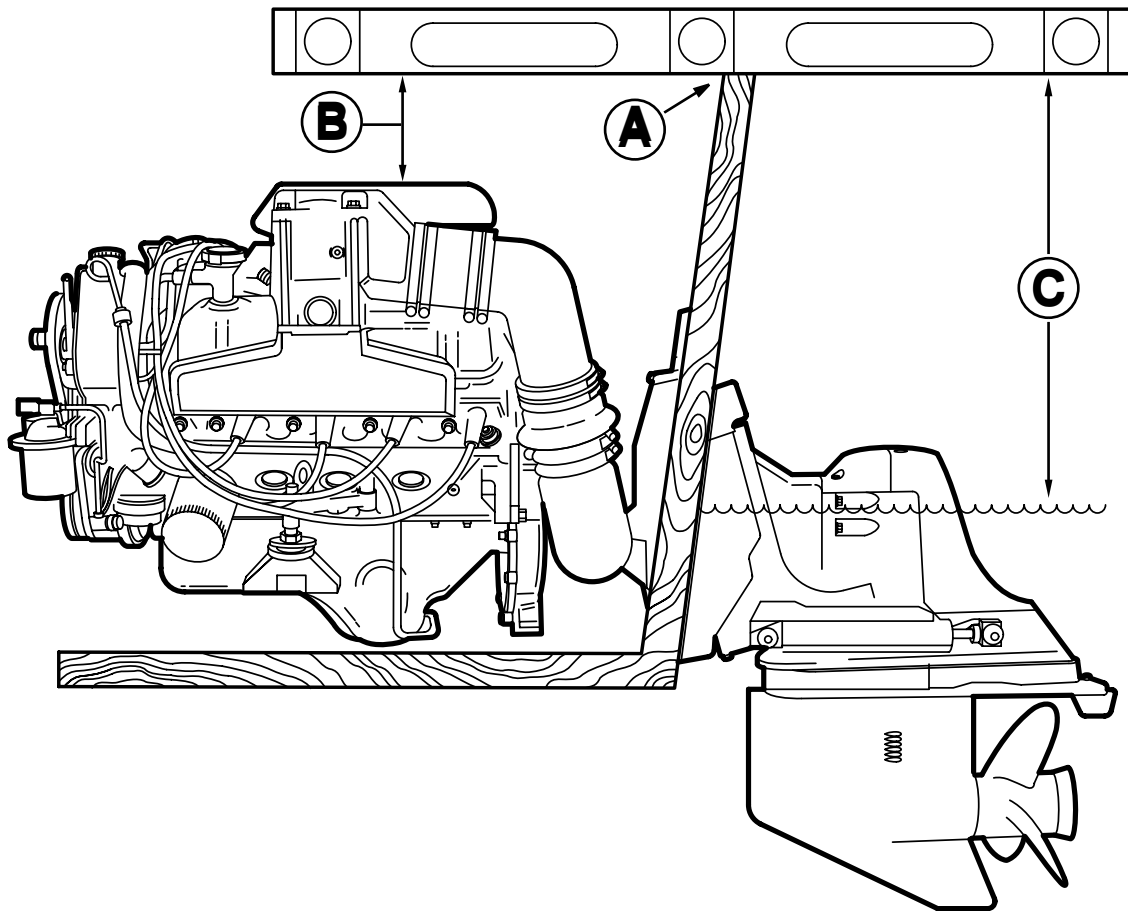

1. To determine minimum engine height, use a level (A) placed on top of the transom, measure from bottom of level to top of elbow (B) and record distance.
2. Measure from bottom of level to static water line (C) and record distance.
3. Subtract dimension (B) from dimension (C) and record result. See engine height requirements below:
  - Measurement (B) minus (C) should not be less than 14 in. (35.6 cm).
4. When engine installations do not meet these specifications, an exhaust elbow high-rise kit must be installed.

**NOTE!** An installation that permits water to enter the engine through the exhaust manifolds) will not be covered by warranty, unless damage is due to defective part(s).

# NOTES

A series of horizontal dashed lines for taking notes.

# Safety Section

## Part A

|   |     |
|---|-----|
| Marine Products and Safety of People Who Use Them . . . . . | S-2 |
| Sterndrive Shift System . . . . .                           | S-3 |
| Sterndrive Throttle Control System . . . . .                | S-4 |
| Sterndrive Steering System . . . . .                        | S-5 |
| Sterndrive Fuel, Electrical System . . . . .                | S-7 |

## Part B

|   |      |
|---|------|
| Marine Products and Safety of People Who Fix Them . . . . . | S-11 |
| Handling Engines . . . . .                                  | S-11 |
| Handling Lead Acid Batteries . . . . .                      | S-12 |
| Gasoline! Handle with Care . . . . .                        | S-13 |
| Hazardous Products . . . . .                                | S-14 |

## Part A - Marine Products and safety of People Who Use Them

Enjoyable boating is the goal of people who design and build marine products. To reach this goal, manufacturers are careful to make sure...

- Product User is informed. . .
- Products are safe and reliable. . .

It's up to you, the People who. . .

- Install accessories. . .
  - Service and Maintain the boat. . .
  - Service and maintain the sterndrive. . .
- . . . to keep the products safe and reliable.

This section talks about safe boating and how you can help keep it safe. Some things you may know . . . but others you may not.

### First!

A word about fasteners . . . plain . . . special . . . all screws, nuts, washers and bolts.

#### Do Not Substitute Fasteners

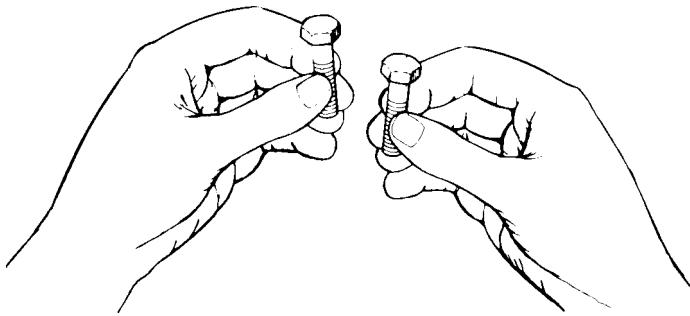

They look the same, but . . . are they?

- The Same Size?
- The Same Strength?
- The Same Material?
- The Same Type?
- Standard or Metric Thread?

**Don't substitute unless you know they are the same in all characteristics.**

### Second!

- Special locking screws and nuts are often used to attach steering, and remote control components to the sterndrive.
- When you remove any part from the sterndrive, keep track of special screws and nuts. Don't mix with other parts
- When reassembling the sterndrive, use only the special screws and nuts intended to hold steering, and control cables, plus related parts.
- Service with parts of known quality that meet Marine Industry (BIA/ABYC) Standard.

## Sterndrive Shift System

The Shift System starts here at the remote control lever . . .

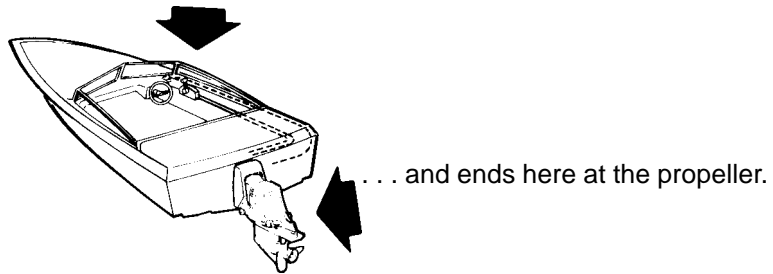

### What's Most Important?

When the control lever is in Forward, Neutral or Reverse position . . .

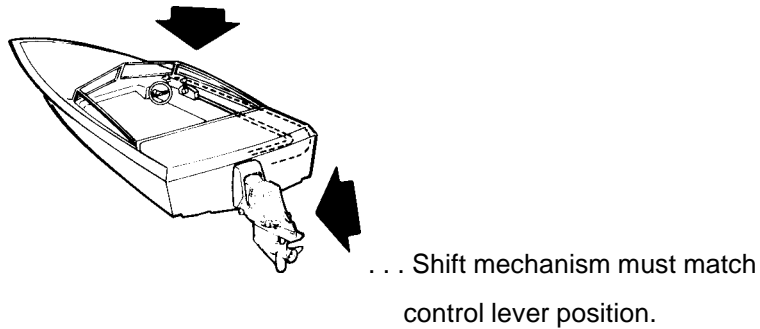

### What Could Happen?

#### ● If . . . Neutral

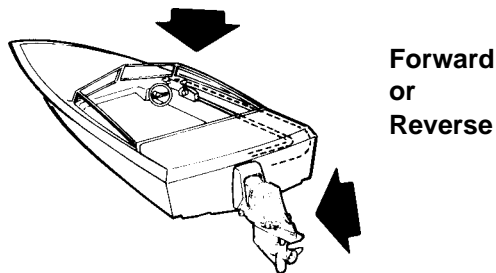

. . . Propeller is still powered (turning) unknown to operator, or engine will start in gear, boat will move unexpectedly.

#### ● If . . . Forward

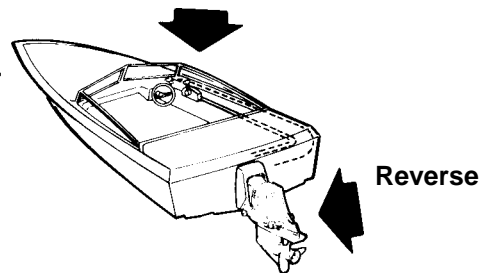

. . . boat will move opposite to direction intended by operator.

### How Can Loss of Shift Control be Minimized? In pre-delivery inspection and when servicing . . .

- Read, understand and follow manufacturers instructions.
- Closely follow the warnings marked with  . . .
- Assemble parts and make adjustments carefully . . .
- Test your work. Don't guess. Make sure propeller does what the operator wants and nothing else.

## Sterndrive Throttle Control System

The throttle Control System starts here and the remote control lever . . .

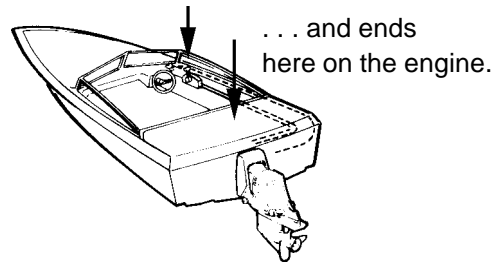

### What's Most Important?

When the control lever is moved from Forward (or Reverse) to Neutral . . .

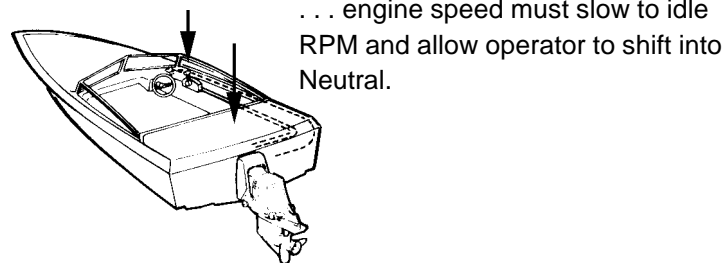

**Operator must be able to stop propeller.**

### What Could Happen?

If operator cannot slow the engine to idle RPM and shift into neutral, (stop propeller), operator could panic and lose control of boat.

### How Can Loss of Throttle Control be Minimized? In pre-delivery inspection and when servicing . . .

- Read, understand, and follow manufacturers instructions.
- Closely follow the warnings marked with  . . .
- Assemble parts and make adjustments carefully . . .
- Test your work. Don't guess. Make sure engine throttle response is smooth.
- Make sure full throttle operating RPM can be reached so operator won't overload engine

## Sterndrive Steering System

The Steering System starts here at the helm . . .

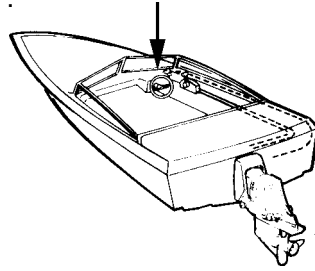

### What's Most Important?

The Steering System . . .

- must be installed properly
- must be adjusted properly
- must be lubricated

. . . and ends here at the propeller on the sterndrive



### What Could Happen?

- . . . if steering system comes apart, boat would turn suddenly and circle . . . passengers and/or operator may be thrown into water and could be hit.

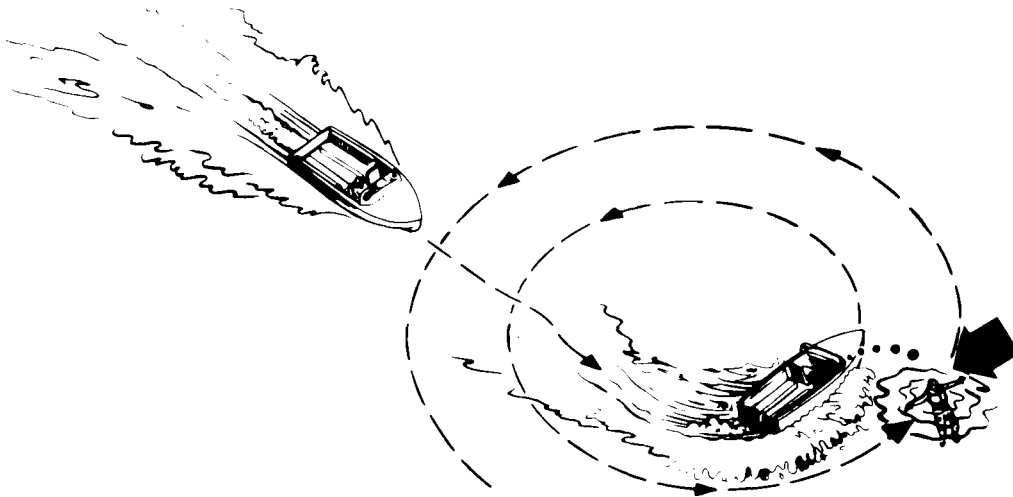

- . . . if steering jams, operator may not be able to avoid obstacles. Operator could panic.
- . . . if steering is loose, operator may not be able to maintain a true course, and could result in loss of boat control.

## How Can Loss of Steering Control be Minimized?

### In pre-delivery inspection and when servicing

- use steering components which meet marine industry (BIA/ABYC) standards . . .
- Read, understand, and follow manufacturer's instructions.
- Assemble parts and make adjustments carefully . . .
- Closely follow the warnings marked with  . . .
- Keep parts moving freely . . . lubricate parts as soon as shown in manuals
- Use bolts, nuts, and washers supplied with steering attachment kits

When power assisted or mechanical steering systems are used, check to uncover possible trouble!

- Cable housing in this area must not be restricted

Why? Unit may go to full turn without turning steering wheel (Power assist models)

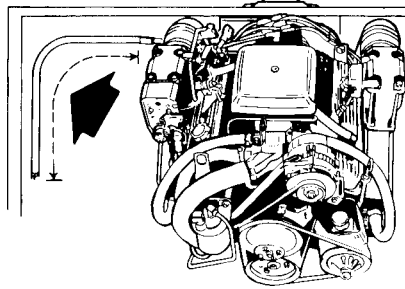

- Steering components must not bind

Why? Possible jamming of steering system.

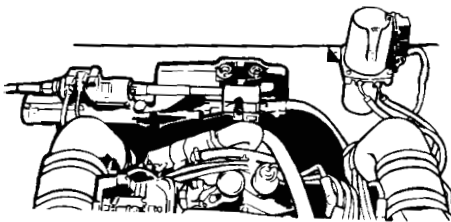

Power steering parts and push/pull cable must be free to move in order to actuate power steering valve when operator turns steering wheel

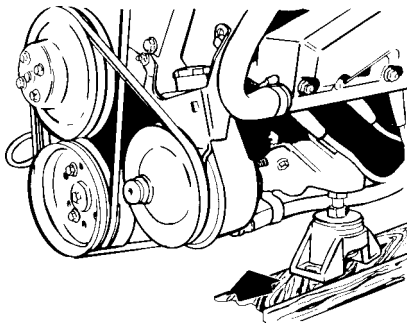

Engine stringer must not interfere with power steering pump and pulley

Maintain proper belt tension.

- Check for damaged parts . . . impacts to the sterndrive like this

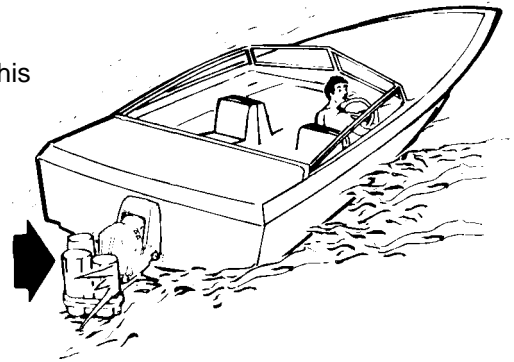
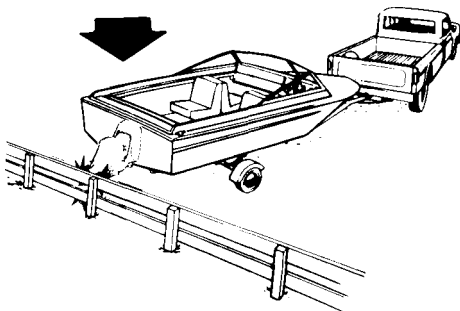

or this . . . or ???

can put stress on steering components. Look for . . .

- Cracked parts
- Bent parts
- Loose fasteners

Replace damaged parts. If weakened, parts could fail later . . . on the water . . . when least expected.



# Sterndrive Fuel and Electrical Systems

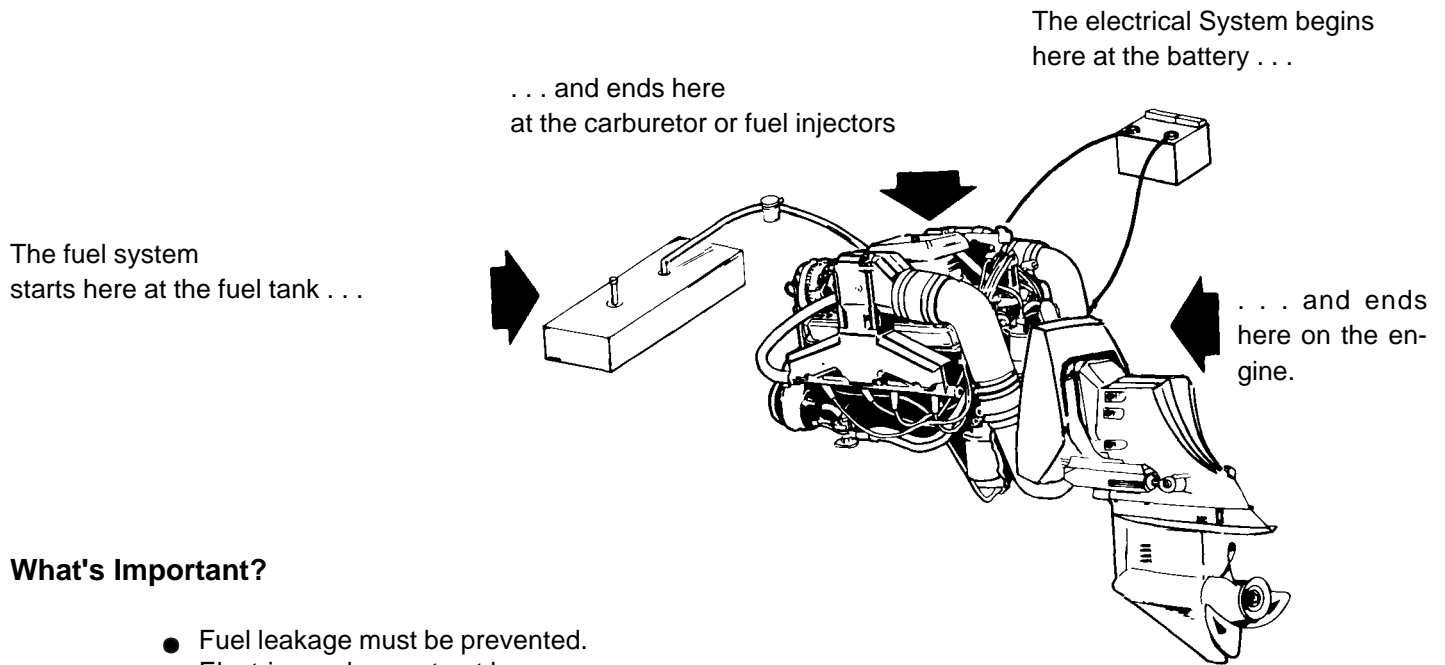

## What's Important?

- Fuel leakage must be prevented.
- Electric sparks must not happen.

## What Could Happen?

Gasoline can explode and/ or burn easily:

- When boating, fuel leaking in the engine compartment could be ignited by a spark from a loose wire connection, or a damaged or deteriorated electrical component.

## How Can Fire and Explosion Be Minimized?

- Read, understand and follow manufacturers instructions.
- Closely follow the warnings marked with  . . .
- Do not substitute fuel or electrical parts with other parts which may look the same. These parts are designed and manufactured to meet special U. S. Coast Guard safety regulations to prevent fire and explosion.

If you work on marine engines, you must understand these U.S. Coast Guard requirements. If you don't have them, write to . . .

. . . and ask for copies of:

|   |                          |
|---|--------------------------|
| -----<br>-----<br>-----   | <input type="checkbox"/> |
| National Technical Information Service<br>Springfield, Virginia 22161 |                          |

(1) Electrical System Compliance Guideline (AD/A-049-638)

(2) Fuel System Compliance Guideline (AD/A-047-767)

These are concise guidelines - easy to read and understand. They explain what must be done to prevent fire and explosions.

- Always use replacement parts specified by the manufacturer. They meet the U.S. Coast Guard requirements. Most automotive parts do not, especially electrical components that must meet ignition protection requirements of the U.S. Coast Guard regulations.
- When nonmetallic parts look to be in poor shape . . . replace them!

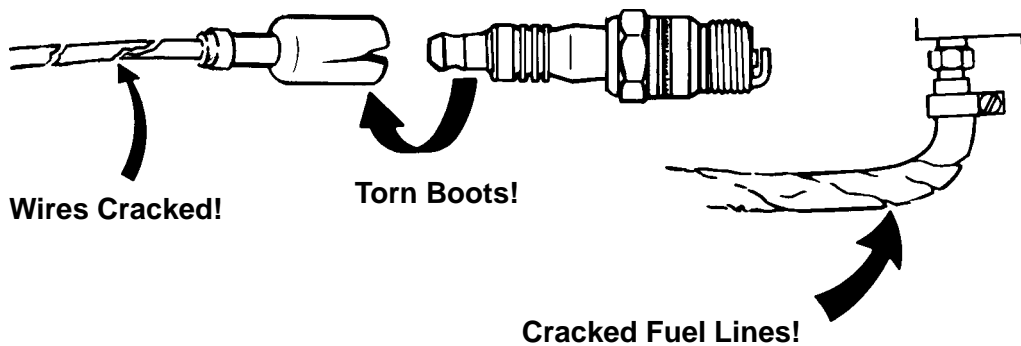

Using parts which meet U.S. Coast guard requirements is only half the job. The other half is your job . . .

It's time for replacement BEFORE sparks and/or fuel leaks occur.

- Replace parts carefully. Make sure nuts and bolts are tight especially when they anchor electrical wires (to prevent sparking). If lock washers are specified - use them. No short cuts or missing parts with either of these CRITICAL safety related systems.
- When refueling, always ground fuel nozzle to the inlet fitting on the boat to prevent the buildup of electrostatic sparks. If you use a funnel, make sure it's metal and ground the fuel nozzle to the funnel.

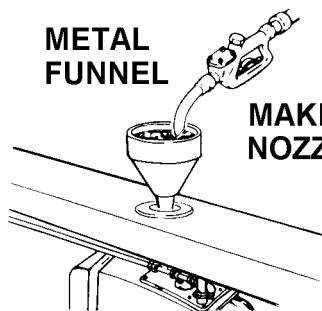

**MAKE SURE  
NOZZLE TOUCHES!**

**WHEN REFUELING  
NEVER . . .!**

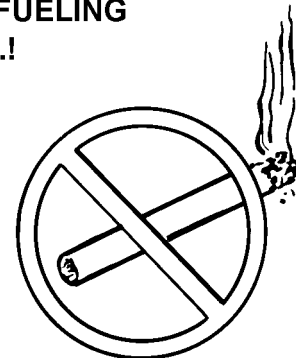

- If you smell gasoline in the engine compartment . . . find its source and stop the leakage.

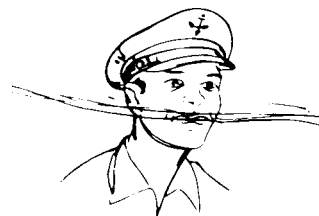

- Follow "Starting Procedure" outlined in the operator's manual.

Always make sure there are no gasoline fumes in the engine compartment before starting the engine. Open the compartment and use your nose. Don't gamble.

- **Backfire flame arrestor** must be in place and securely attached to the air intake.

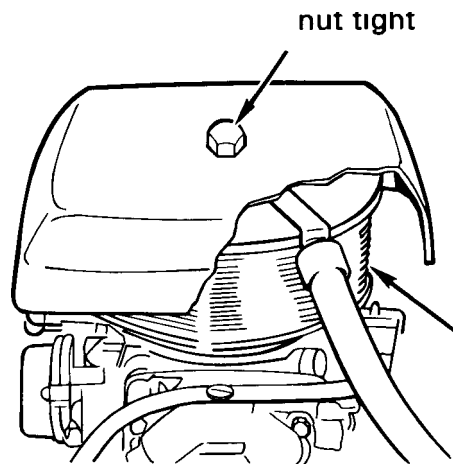

Do not alter the backfire flame arrestor.

If loose, damaged, or altered, an engine "backfire" may pass through the flame arrestor assembly into the engine compartment. If fumes are present in compartment, fire and explosion could result.

## Summing Up

Now you know some things that can take the joy out of enjoyable boating.

No doubt about it . . . it takes time!

- Reading and understanding instructions.
- Reading and understanding warnings marked with  . . .
- Putting parts together correctly . . .
- Making correct adjustments . . .
- Testing you work.

### and making sure

- Worn or damaged parts are replaced,
- Replaced parts are like originals . . . in every way.
- Customer is told of things which need attention . . .

**But do you really want the alternative?**

## Part B - Marine Products and Safety of People\* Who Fix Them

Part A talked about safe boating and how you, the mechanic, can help keep it safe for the boater. But what about you? Mechanics can be hurt while . . .

- Servicing boats
- Servicing sterndrives
- Troubleshooting problems
- Testing their work

Some items you'll know . . . others you may not.

### When Lifting Engines

If hoist is poor shape . . . or too small for the job

- Engine may drop suddenly

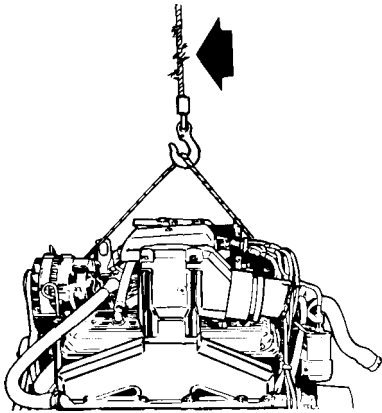

DR3471

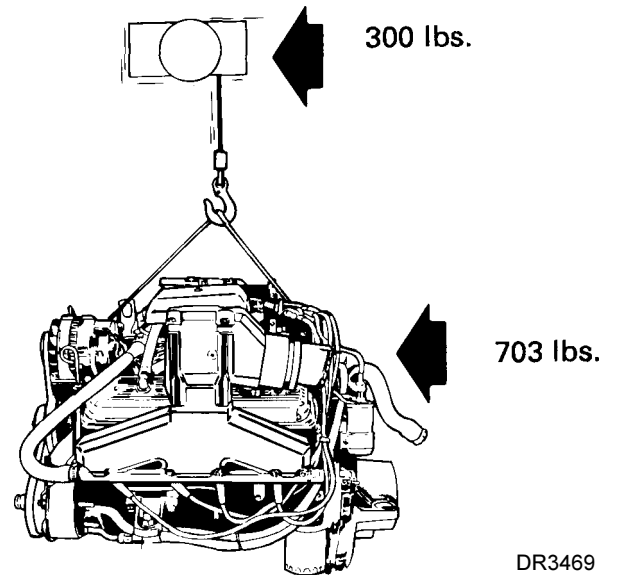

DR3469

- Make sure shop aids have extra capacity — and keep them in good repair!

### When Running Engine with Engine Compartment Cover Removed

The engine compartment cover is a guard. When you remove the cover / guard to work on the engine, remember:

- Loose clothing (open shirt sleeves, neckties), long hair, jewelry (rings, watches, bracelets), hands, arms, belts can be caught by moving belts or spinning pulleys
- Handle high voltage ignition components carefully. They can shock you and may cause you to recoil into moving parts.

Two people working together on a running engine must look out for each other. Never, ever, hit the key to start the engine before signalling to your partner. (He may be leaning over the engine with his hands on a belt, or a "hot" electrical part, near the propeller, etc.)

\*Mechanics, technicians, backyard do-it-yourselfers.

- Exhaust gasses of running engines contain carbon monoxide. . . you can't see it. . . you can't smell it. . . you can't taste it. . . but it's there whenever an engine runs. . . and it's deadly!

When you smell the other gasses in the exhaust, you are inhaling carbon monoxide. Run engines only in well ventilated areas.

## Eyes Need help

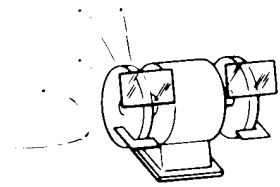

- Grinding



- End of Cables

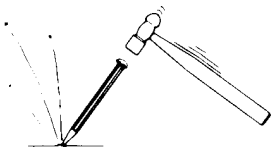

- Chiseling  
(steel on steel)  
(Tip: Use plastic or brass type hammers.  
They don't chip off as easily as steel hammers.)



- Sprayed Cleaners, Paints

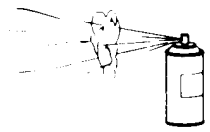

- Acid

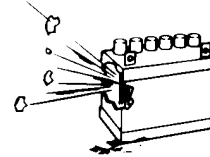

## Handling Lead Acid Batteries

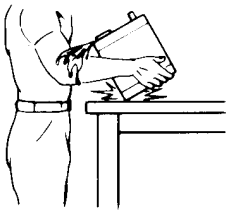

- If spilled or splashed on any part of body..

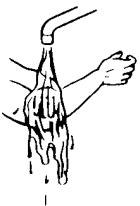
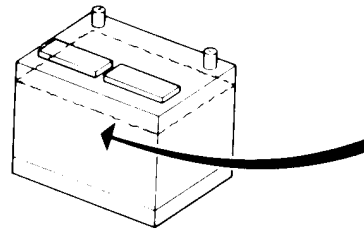

Wash with lots of water. . .

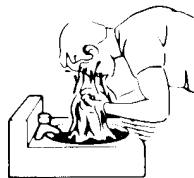

- If solution gets into eyes. . . Wash. . . and see a Doctor, fast!



## Charging Lead Acid Batteries

**1** Attach and remove these cables with charger unplugged from 110 volt wall socket. (Prevents shocks if the charger is defective.)

**2** Observe correct polarity when connecting these charger leads.

**3** Always charge in a well ventilated area. Charging causes acid solution to give off hydrogen gas through the vents in the caps. . . Make sure vents are open. If clogged, pressure inside may build. . . battery may explode.

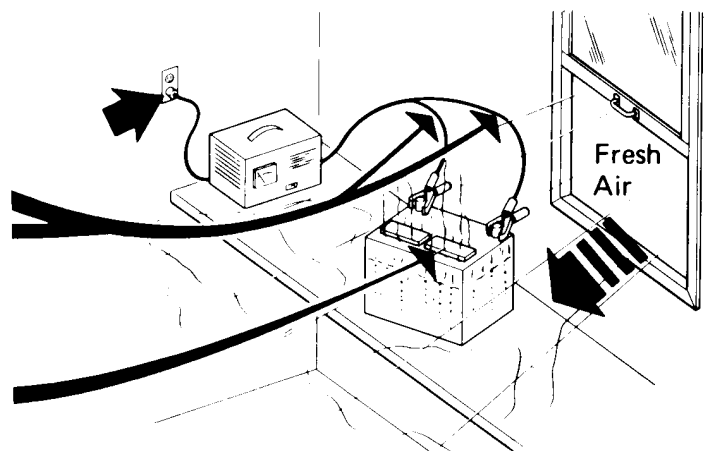

Battery gas is explosive!  
While charging or discharging,  
remember. . .

No Smoking  
No Flames  
No Sparks



Never yank cables off  
battery posts. . . it's a sure  
way to make lots of  
sparks. . .surrounded by battery gas

Don't check battery condition  
by placing metal objects  
across posts.

You're sure to make sparks  
and serious burns are  
possible.

After Charging. . .



- Shut off charger
- Remove charger plug from wall socket  
Then. . .
- Take charger cable off battery posts

### Gasoline! Handle With Care

- When you smell any odor of gasoline,  
explosion is possible
- Gasoline fumes are heavier than air and will sink  
to the lowest point in the boat or room,  
and will stay there. . . waiting

- If the air around you is quiet . . . the pilot light in  
the heater may  
ignite the heavy fumes  
before your nose ever  
smells the fumes . . .

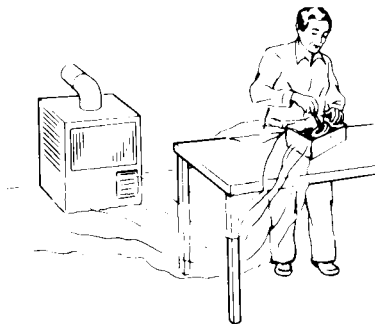

Gasoline explodes easily and violently when  
mixed with air

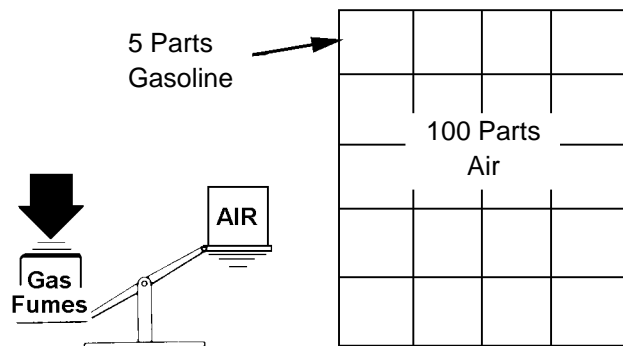

### What Can you Do?

- Store properly . . .
- Fill portable tanks outside boat to prevent spillage in  
boat
- Use fuel for fuel . . . not for a solvent
- If fumes are smelled (in shop, basement, garage), immediately:
  - Put out open flames, cigarettes, sparking devices
  - Wipe up spill or leak; get towels, rags outside fast
  - Check lowest area for fumes; open doors or win-  
dows

Store in sturdy,  
sealed gas can  
. . .and . . .  
keep outside



● Know items in and around repair area which can ignite gasoline fumes . . . Control them if fumes are smelled.

- Matches, cigarettes, torches, welders
- Electric motors (with unsealed cases)
- Electric generators (with unsealed cases)
- Light switches
- Appliance pilot lights (furnace, dryer, water heater)
- ??????????

How many of these are in your area?

# Hazardous Products

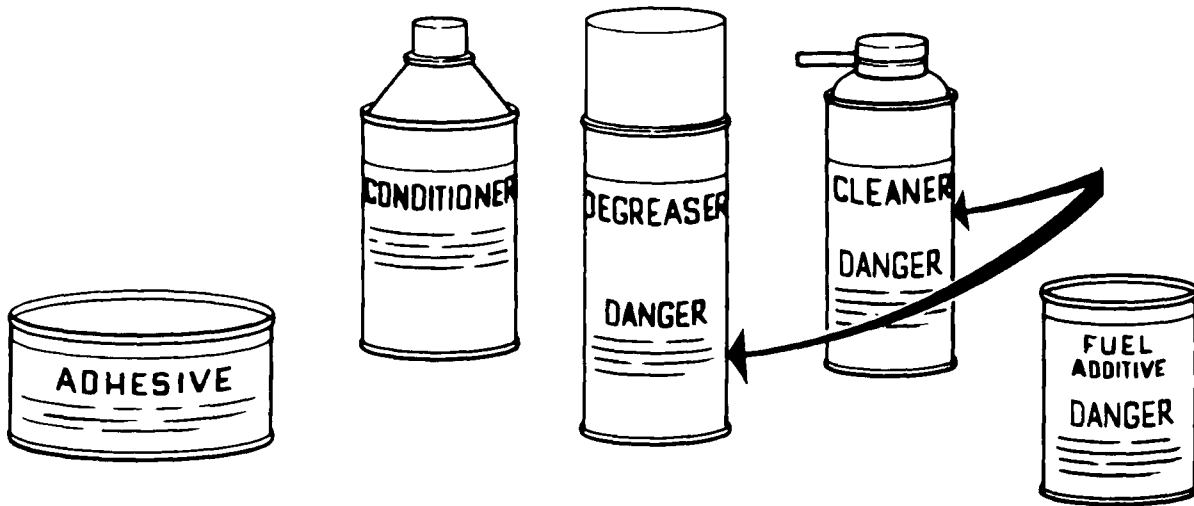

Read the container label. It tells you . . .

- "How, and where, to use,"
- "How to give First Aid," and have "recommended" first aid materials on hand- should an emergency arise
- "How to dispose of can,"

Remember: Little children are very curious and will try to taste everything, so . . .

. . . yummmmmmmmmmm



Keep containers away from children

